



Reactive Power Support Services in Electricity Markets

*Costing and Pricing of Ancillary Services
Final Project Report*

Power Systems Engineering Research Center

*A National Science Foundation
Industry/University Cooperative Research Center
since 1996*





Cornell • Arizona State • Berkeley • Carnegie Mellon • Colorado School of Mines
Georgia Tech • Illinois • Iowa State • Texas A&M • Washington State • Wisconsin

Reactive Power Support Services in Electricity Markets

Costing and Pricing of Ancillary Services Project
Final Report

Project Team

Peter W. Sauer, Project Leader
Thomas J. Overbye
George Gross

University of Illinois at Urbana-Champaign

Fernando Alvarado
University of Wisconsin – Madison

Shmuel Oren
University of California at Berkeley

James Momoh
Howard University

PSERC Publication 00-08

May 2001

Information about this Project

For information about this project contact:

Peter W. Sauer, Project Leader
Professor
Electrical & Computer Engineering
University of Illinois at Urbana-Champaign
1406 W Green St
Phone: 217-333-0394
Fax: 217-333-1162
Email: sauer@ece.uiuc.edu

Additional Copies of the Report

Copies of this report can be obtained from the Power Systems Engineering Research Center's website, www.pserc.wisc.edu. The PSERC publication number is 00-08. For additional information, contact:

Power Systems Engineering Research Center
Cornell University
428 Phillips Hall
Ithaca, New York 14853
Phone: 607-255-5601
Fax: 607-255-8871

Notice Concerning Copyright Material

Permission to copy without fee all or part of this publication is granted if appropriate attribution is given to this document as the source material.

© 2001 University of Illinois at Urbana-Champaign. All rights reserved.

ACKNOWLEDGEMENTS

The work described in this report was sponsored by the Power Systems Engineering Research Center (PSERC). We express our appreciation for the support provided by PSERC's industrial members and by the National Science Foundation through the following grants received under the Industry/University Cooperative Research Center program: NSF EEC 96-15792 (University of Illinois at Urbana-Champaign), 96-16221 (University of California at Berkeley) and 96-15778 (University of Wisconsin-Madison). We also acknowledge the University of Illinois Grainger Endowments for their cost sharing.

EXECUTIVE SUMMARY

This document is the final report of the PSERC project on “Costing and Pricing of Ancillary Services.” The project title reflects the original proposal that was prepared to examine several of the ancillary services associated with the various scenarios of a restructured industry. During the course of the project, the scope was reduced to issues associated only with reactive power support services. These services include the resources available to generators as well as transmission and distribution agents. The project tasks were:

- Task 1. Investigate existing information that has appeared in the literature and EPRI projects.
- Task 2. Investigate the costs and value of reactive power and voltage support from a local view. Investigate nodal costs based on optimal power flow incremental costs for satisfying reactive power demand and voltage constraints. Examine the significance of nodal costs for VARs.
- Task 3. Investigate constraints on generator operation due to VAR requirements as a cost to the provider.
- Task 4. Investigate the costs and value of reactive power and voltage support from a system view. Examine the constraint of margin to voltage collapse and its sensitivity to reactive sources as a limitation to economic transfers. Examine the formulation of this as “congestion charges” related to the limitations of transfers due to inadequate voltage support at either load or generation sites.
- Task 5. Relate the economic value of reactive power controllers and reactive power sources such as capacitor banks and generator excitation systems to their cost.

Results obtained for these tasks are presented in the report. As experience grows with alternative electric power market designs in the U.S. and abroad, new research questions emerge about ancillary services in general and reactive power support service in particular. This report addresses fundamental relationships between costs, prices and physical provision of reactive power. Therefore, research on the new questions will necessarily build on these fundamental relationships.

The primary contributions of this project are in the areas of nodal pricing of reactive power, optimal VAR resource siting, cost determination including lost opportunity costs to generators, market power measurement, reactive power supply allocation, and the concept of spectral analysis of reactive power dynamics. While this report summarizes the results of these contributions, additional details are included in the individual publications associated with this project. These publications are listed in the Bibliography of Project Publications.

TABLE OF CONTENTS

1	INTRODUCTION.....	1
1.1	Background on Ancillary Services.....	1
1.2	Existing Information	2
2	REACTIVE POWER PLACEMENT ANALYSIS.....	5
2.1	Background	5
2.2	Reactive Power Siting Indices.....	6
2.3	Ranking of Sites	10
3	NODAL PRICING OF REACTIVE POWER	15
3.1	Optimal Power Flow	15
3.2	Value of a Reactive Power Source: The Capacitor Bank.....	18
4	THIRD-PARTY REACTIVE POWER SUPPORT ISSUES.....	23
4.1	Costing and Pricing of Voltage Support.....	23
4.2	Sensitivity of the Margin to Voltage Collapse	29
5	REACTIVE POWER LOSS ALLOCATION.....	35
5.1	Simple Pro-Rata Approach.....	40
5.2	An Incremental/Average Approach.....	40
5.3	Aumann-Shapley Approach	41
5.4	A Flow-Based Approach.....	46
6	RELATING VALUE AND COST OF VARs.....	49
6.1	Unit Operation with System Considerations	49
6.2	Reactive Support Service and Lost Opportunity Costs	56
7	MARKET POWER IN PROVIDING REACTIVE SUPPORT SERVICES.....	67
7.1	Background	67
7.2	Measuring Reactive Market Power	67
8	DYNAMIC ASPECTS OF REACTIVE POWER.....	73
8.1	General Concepts	73
8.2	Time Domain vs. Frequency Domain	74
8.3	An Example.....	75

9 CONCLUSIONS AND SUGGESTIONS FOR FUTURE RESEARCH.....	81
9.1 Conclusions.....	81
9.2 Suggestions For Future Research.....	82
REFERENCES.....	83
BIBLIOGRAPHY OF PROJECT PUBLICATIONS.....	88

1

INTRODUCTION

1.1 Background on Ancillary Services

Ancillary Services, as defined in the Federal Energy Regulatory Commission (FERC) Order 888, consist of six services which make up the basic components needed for open access operation of electric power transmission systems [1]. They are:

- 1) Scheduling, System Control and Dispatch
- 2) Reactive Supply and Voltage Control from Generation Sources
- 3) Regulation and Frequency Response
- 4) Energy Imbalance
- 5) Operating Reserve - Spinning
- 6) Operating Reserve - Supplemental

FERC did not specify technical details of the services, and the costing methods for the services remain ad hoc, varying widely from one provider to another. One estimate of the ancillary services market is \$12 billion a year in the U.S. or about \$4/MWhr [1].

The North American Electric Reliability Council (NERC) followed up on FERC's initiative by conducting its own more technical study to identify ancillary services. Together with the Electric Power Research Institute (EPRI), they identified 12 Interconnected Operations Services (IOS) [1]. They are:

- 1) Regulation
- 2) Load Following
- 3) Energy Imbalance
- 4) Operating Reserve – Spinning
- 5) Operating Reserve – Supplemental
- 6) Backup Supply
- 7) System Control
- 8) Dynamic Scheduling
- 9) Reactive Power and Voltage Control from Generation Sources
- 10) Real Power Transmission Losses
- 11) Network Stability Services from Generation Sources
- 12) System Black start Capability

The NERC IOS Working Group also identified an Ancillary Services Market Framework consisting of two distinct parts: a resource supply market and an ancillary service delivery

market. NERC is currently developing operating and engineering standards for IOS services including measurement aspects.

While this project recognized the nature of the specific definitions of these ancillary services, the research took a broader approach to reactive power and voltage control so that future changes in the role of these services might be considered.

1.2 Existing Information

The majority of work sponsored by the Electric Power Research Institute [2-7] focuses on the local view, i.e. the costing of reactive power due to the VAR impact on generating station efficiency as well as on capital and operation/maintenance (O&M) costs. The work by the Department of Energy provides results on the local view as well as the system view [8-11]. The local view of these reports gives extensive consideration to the impact of VAR loading on both the capital and O&M (including unit losses) costs. Reference [12] explicitly addresses the issue of lost opportunity cost of generation due to capability curves. This will be considered in detail in section 6.

Based on the examination of this literature, we estimate the cost of voltage control and reactive power production capability based on investment costs as follows:

- 1) Capital costs for 1,000 MW plant at \$500/KW gives \$500,000,000
- 2) Multiplying by an annualization factor of 0.2 gives \$100,000,000 per year
- 3) Dividing by a load factor of 0.7 gives \$142,857,143 per year
- 4) For 8,760 hours per year the cost is \$16,308 per hour
- 5) For 1,000 MW the capital cost is \$16/MWhr
- 6) Using plant O&M cost as 5% of capital cost (\$0.8/MWhr) brings the total plant cost (not including fuel) to about \$17/MWhr.
- 7) Assuming generation equipment to be 5% of the total plant capital cost, and voltage control and reactive power supply to be 50% of the generation equipment costs gives about \$0.40/MWhr for voltage control and reactive power supply equipment investment plus O&M. The literature indicates that voltage control and reactive power supply should be about 10% of the total ancillary service costs, which are estimated to be about 10% of total energy service costs. The above figure would be consistent for a total energy service cost of \$40/MWhr. Here total energy service costs include capital and O&M costs associated with generation and transmission services.

The literature also indicates that the incremental cost of providing reactive power is on the order of \$1/MWhr.

Most of the information on the system view of reactive power costing and pricing is based on Optimal Power Flow (OPF) analysis. References [13-17] provide the initial concepts and introductions to the topic of nodal pricing of reactive power. Reference [18] summarizes several OPF algorithms for reactive power costing and pricing. The paper states that their investigation found that the marginal cost of reactive power is negligible compared to that of real power, but that transmission rates for reactive power are not negligible. References [19-28] provide additional OPF approaches to reactive power costing and pricing. References [29-37] provide ideas and examples of general approaches to various ancillary service costing and pricing issues.

The following is the EPRI abstract for their program ROPES (Real and Reactive Optimization for Planning and Scheduling Program):

“ROPES is a security constrained optimal power flow (SCOF) software program which is also a tool for optimal sizing and siting of VAR devices such as reactor, capacitor banks, static VAR systems, series capacitors, etc. Given the network data and additional information about the objective function, controls to be activated, list of contingencies, etc., the program, in the SCOF mode, finds a new operating point which optimizes the objective function and satisfies a set of physical and operating constraints for the base case and contingency situations. In the VAR planning tool mode, economic information about installation costs at the candidate sites or branches should be provided and the program determines a minimum cost expansion plan in VAR equipment which ensures feasible system operation simultaneously for the normal state (base case) and under contingency situations.”

In addition to performing VAR Planning and Series Compensation Planning, ROPES contains the following objective functions:

- a. Minimum Production Cost
- b. Flow Optimization
- c. Load Shedding Minimization
- d. Minimization of Control Variable Movement

Version 2.0 of this program is in production and available from EPRI.

REACTIVE POWER PLACEMENT ANALYSIS

2.1 Background

A great deal of research has been done on optimal allocation and sizing of reactive power sources to improve the system voltage profile and reduce losses [41-47]. Traditionally, transmission customers are charged for reactive power support service based only on the costs of transmission equipment or on power factor penalties.

In an open access environment, the transmission system operator will continue to be responsible for coordinating the generation and transmission systems for the reactive power service and control based on a new price mechanism that can reflect the embedded costs incurred by the utilities for wholesale transactions [48]. Therefore, real-time reactive power pricing addresses the important issue of providing information to both the utility and consumers about the true system cost. Real-time reactive power pricing has been shown to perform better than the power factor penalty scheme in providing incentives to all customers to reduce their reactive power consumption irrespective of their power factor [48-52]. Reference [49] proposed an integrated framework for optimal reactive power planning and its spot pricing, in which the selection of VAR source sites is based only on the real power generation operation benefit-to-cost ratio for a capacitor on a load bus. This approach is superior to the traditional one in which the sites of new VAR sources are either simply estimated or directly assumed. However, the approach neglects the effect of voltage improvement and system loss reduction in the selection of VAR source sites. In the new competitive environment, the actual reactive power output should be controlled by system operators taking into account voltage security and transmission losses.

Reference [51] provides a detailed analysis of a pricing structure for providing reactive power service and placement based on Cost Benefit Analysis (CBA) and Optimal Power Flow (OPF) analysis. This chapter summarizes the results of that work.

Three parallel methods can be used to determine the potential sites for new VAR sources, namely: the cost-benefit analysis (CBA), the sensitivity method (SM) and the voltage security margin method (VSMM). CBA, SM and VSMM reflect the improvement of the system's operation state after the VAR support service is provided, although the results from CBA, SM and VSMM may be different. Unfortunately, it is difficult to find a unified process for ranking these results. Moreover, all three methods have not included other qualitative relationships for considering relative importance of different VAR source sites.

The AHP, which is a simple and convenient method to analyze the complicated problem of VAR support siting, can help to quantify the decision-maker's thinking [53, 54]. The analytic hierarchical process (AHP) model incorporates the results of CBA, SM and VSMM as well as

considering the network topology for each candidate VAR source site. Thus, it provides a useful means for considering factors in the ranking and selection of VAR source locations.

The steps of the AHP algorithm may be written as follows [54]:

Step 1: Set up a hierarchy model.

Step 2: Form a judgment matrix. The value of elements in the judgment matrix reflects the user's knowledge about the relative importance between every pair of factors.

Step 3: Calculate the maximal eigenvalue and the corresponding eigenvector of the judgment matrix.

Step 4: Check hierarchical rank and consistency of results.

We can perform the hierarchical rank according to the value of elements in the eigenvector, which represents the relative importance of the corresponding factor. The consistency index CI of a hierarchy ranking is defined as

$$CI = (\lambda_{max} - n) / (n - 1) \quad (2-1)$$

where λ_{max} is the maximal eigenvalue of the judgment matrix, n is the dimension of the judgment matrix. The stochastic consistency ratio is defined as:

$$CR = CI / RI \quad (2-2)$$

where RI is a set of given average stochastic consistency indices.

It is possible to precisely calculate the eigenvalue and the corresponding eigenvector of a matrix, but this would be time-consuming. Moreover, it is not necessary to precisely compute the eigenvalue and the corresponding eigenvector of the judgment matrix because the judgment matrix is formed from the subjective judgment of the user, and is therefore has some range of error. Therefore, the approximate approaches, which were presented in the reference [54, 55], are adopted in the report to compute the maximal eigenvalue and the corresponding eigenvector.

2.2 Reactive Power Siting Indices

The reactive power pricing of each VAR source bus is divided into two parts: fixed and variable. An Optimal Power Flow (OPF) solution gives the amount of reactive power support needed at each load bus. It is necessary to use cost-benefit analysis (CBA) to analyze whether the new VAR sources would be cost-effective when they are actually installed.

The corresponding investment cost (including installing cost) of the VAR source is the fixed part of VAR pricing at this VAR source bus; i.e.,

$$C_{f(i)} = C_{ci} q_{ci} \quad (2-3)$$

where

$C_{f(i)}$: fixed part of reactive power pricing at VAR source bus i and
 C_{ci} : unit investment cost due to allocation of capacitors at load bus i (\$/MVAR).

The variable cost of reactive power support service is determined based on capability and contribution to improvement of system performance including factors such as security, reliability and economics. Contribution or value of reactive support to the system can be evaluated by calculating the sensitivity of the objective function with respect to reactive power support. This sensitivity reflects dollar savings from applying VAR support service and control. Therefore, the variable part of reactive power pricing at this VAR source bus can be obtained through computing the power loss cost saving from applying reactive power support service.

$$C_{V(i)}(t) = -\lambda \left. \frac{\partial P_L}{\partial Q_i} \right|_t \times q_{ci}(t) \quad (2-4)$$

where

$C_{V(i)}(t)$: variable part of reactive power pricing at VAR source bus i at time t;
 q_{ci} : reactive power of capacitor at bus i at time t;
 λ : electricity price (\$/MWhr); and
 $\partial P_L / \partial Q_i$: sensitivity of system power loss objective function with respect to reactive power support (capacitor).

The negative symbol in Equation (2-4) means that system real power loss will reduce as the capacity of the capacitor increases. It is obvious that the variable part of VAR pricing at the same bus might vary over an operation period; i.e., VAR pricing is time-dependent.

Thus, the reactive power pricing on VAR source bus at time t can be obtained as follows.

$$C_{P(i)}(t) = C_{f(i)}(t) + C_{V(i)}(t) \quad (2-5)$$

where

$$C_{f(i)}(t) = \frac{\alpha C_{f(i)}}{8760} \quad (2-6)$$

$$\alpha = \frac{r(1+r)^n}{(1+r)^n - 1} \quad (2-7)$$

$C_{f(i)}(t)$: hourly based fixed cost of VAR pricing;

r : interest rate;

- n : capital recovery years; and
 α : capital recovery factor (CRF).

It was supposed that 1 year = 8,760 hours in equation (2-6).

Cost-Benefit Analysis (CBA)

Only load buses where it is cost-effective should be selected as new VAR source sites. Therefore, it is necessary to use cost-benefit analysis (CBA) to analyze whether the new VAR sources would be cost-effective when they are actually installed. The following benefit-to-cost ratio (BCR) was used for the selection of new VAR source sites.

$$BCR = \frac{\sum_{t=1}^{24} \lambda (P_L^t(0) - P_L^t(q_{Ci}))}{C(q_{Ci})} \quad (2-8)$$

or

$$BCR^t = \frac{P_L^t(0) - P_L^t(q_{Ci})}{C(q_{Ci}) / 24} \quad (2-9)$$

$$C(q_{Ci}) = \frac{\alpha C_{Ci} q_{Ci}}{365} \quad (2-10)$$

where

- $P_L^t(0)$: system real power loss at time t before capacitor at bus i is installed;
 $P_L^t(q_{Ci})$: system real power loss at time t after capacitor at bus i is installed; and
 $C(q_{Ci})$: equivalent daily investment cost of capacitor at load bus i (\$/day).

Sensitivity Method (SM)

The magnitude of the bus VAR/voltage sensitivity can be expressed by the total system incremental bus voltage $\sum \Delta V_i$, which is obtained by increasing a small reactive power injection at a given load bus. The larger the value of $\sum \Delta V_i$, the more sensitive voltages will be to a change of reactive injection at a given bus. This means that a load bus with the large value of $\sum \Delta V_i$ is a good candidate as a VAR source site.

The following is the sensitivity index for each load bus.

$$SM_i^t = \frac{\sum_{j \in N} \Delta V_j^t}{\Delta Q_i^t} = \frac{\sum_{j \in N} (V_j^t(\Delta Q_i) - V_j^t(0))}{\Delta Q_i^t} \quad (2-11)$$

where

- $V_j^t(0)$: voltage magnitude at bus j at time t before reactive injection at bus i is changed;
 $V_j^t(\Delta Q_i)$: voltage magnitude at bus j at time t after a new reactive injection is added at bus i ; and
 ΔQ_i^t : increased reactive power injection at load bus i at time t .

Voltage Security Margin Method (VSSM)

Let $V_i(0)$ be the voltage at bus i under the normal operational state. Generally, $V_i(0)$ is within voltage limits, i.e., safe if no system parameters (loads or lines) change. The value of $(V_i(0) - V_{i\min})$ is called voltage security margin (VSM) at bus i . In the contingency case, such as a transmission line outage, the voltage magnitudes at buses may be reduced. This means that the voltage security margin of each bus in a contingency case may be smaller than that in the normal case. The value of VSM at some buses may be negative under a serious contingency case; in this case, the corresponding bus voltage is not safe. Obviously, the bus with a negative or very small VSM will be a good candidate as a new VAR source site. Since the values of VSM may be different for the same bus under a different contingency case, the minimal VSM will be used for each bus. This report defined the following voltage security margin index for the selection of new VAR source sites as

$$VSMM_i^t = \frac{V_i^t(0) - \min[V_i^t(l)]}{V_i^t(0) - V_{i\min}} \quad l \in Nl \quad (2-12)$$

where

- $V_i^t(0)$: voltage magnitude at bus i at time t in the normal case;
 $V_i^t(l)$: voltage magnitude at bus i at time t in the case of line l outage; and
 $V_{i\min}$: lower limit of voltage at bus i .

It can be shown from Equation (2-12) that if $VSMM_i^t = 1$, the voltage security margin is zero; i.e., the voltage at bus i reached its lower limit. If $VSMM_i^t < 1$, the voltage at bus i is safe. The smaller the $VSMM_i^t$, the larger is the voltage security margin under a given contingency. If $VSMM_i^t > 1$, the voltage at bus i is not safe; i.e., it violates the lower limit.

2.3 Ranking of Sites

All three methods (CBA, SM and VSMM) presented in the previous section reflect the improvement of the system operation state after the VAR support service is provided. But the rankings of potential sites for VAR support using these three methods may differ due to their independent nature. The problem is how to find a unified process for ranking these results. Moreover, it is also very difficult to deal with other qualitative relationships in ranking, such as relative importance of different VAR source sites.

To obtain a unified VAR source location ranking, a hierarchy model is devised according to the principle of AHP. The hierarchical model of VAR source site ranking consists of three sections: (1) the unified ranking of VAR source sites; (2) the performance indices in which the PI_C reflects the relative importance of load nodes; and (3) load buses C_1, \dots, C_m which identify the candidate VAR source sites.

The performance indices PI_B , PI_S and PI_M are defined as:

$$PI_B = BCR^t \quad (2-13)$$

$$PI_S = SM \quad (2-14)$$

$$PI_M = VSMM^t \quad (2-15)$$

Eigenvectors of PI_B , PI_S and PI_M can be obtained through normalization. However, it is very difficult to exactly obtain PI_C and the corresponding eigenvector. They can be obtained through forming and computing the judgment matrix PI_C -C according to the location of the load buses in the power network and to the experience of operators. In addition, the judgment matrix A-P, shown in Table 2.1 can also be obtained according to the nine-scale method [53, 54] for practical operating cases in power systems. For example, if the operator thinks that the BCR index PI_B is slightly more important compared to VSMM index PI_M , then the corresponding element in judgment matrix should be “2”. If both indices of BCR and SM are thought to be equally important, the corresponding element in the matrix should be “1”.

Table 2.1. Judgment Matrix A-PI

A	PI_B	PI_S	PI_M	PI_C
PI_B	1	1	2	3
PI_S	1	1	1 / 2	2
PI_M	1 / 2	2	1	2
PI_C	1 / 3	1 / 2	1 / 2	1

Proposed VAR Pricing and Placement Scheme

A proposed VAR pricing and VAR placement scheme is shown in Figure 2.1.

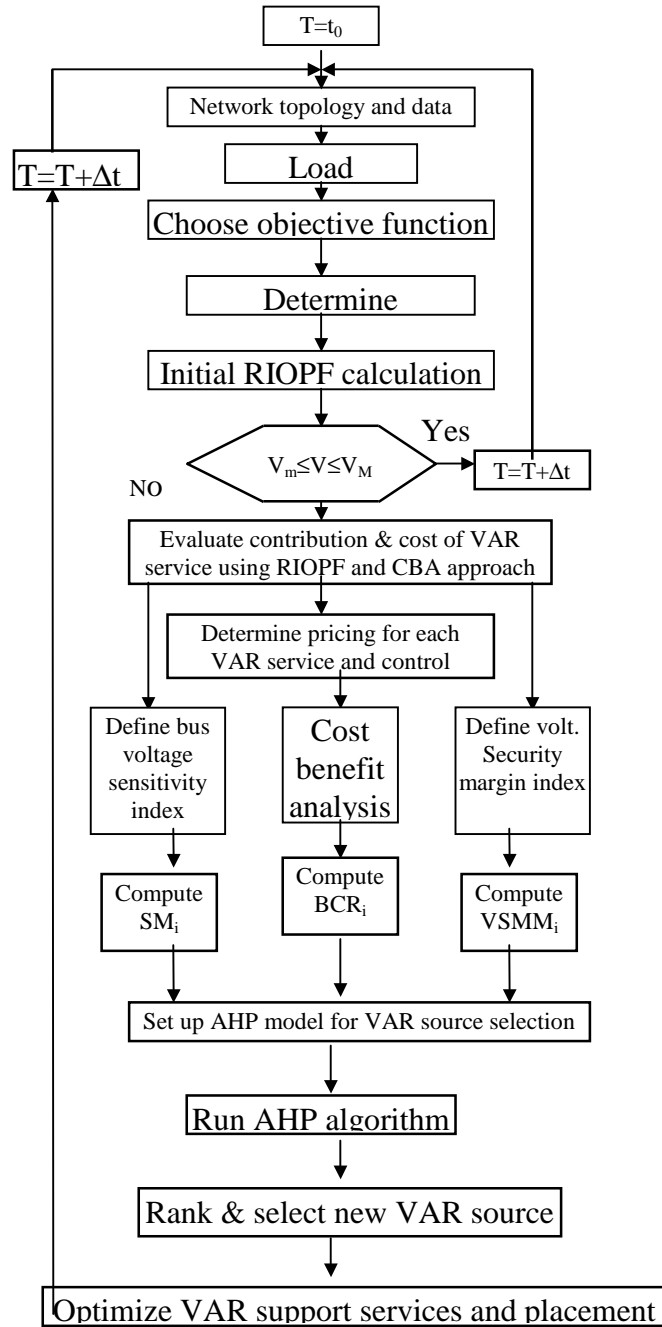

Figure 2.1 Real-time VAR pricing and VAR placement

Test Results

The proposed approach was examined with the IEEE 30-bus system for the peak load condition shown in Table 2.2.

Table 2.2 Real and Reactive Load (LSF=1.4)

Bus No.	Real load (p.u.)	Reactive load (p.u.)	Bus No.	Real load (p.u.)	Reactive load (p.u.)
2	0.3038	0.1778	17	0.1260	0.0812
3	0.0336	0.0168	18	0.0448	0.0210
4	0.1064	0.0504	19	0.1330	0.0630
5	1.3188	0.4200	20	0.0308	0.0140
7	0.3192	0.1526	21	0.2450	0.1568
8	0.4200	0.4200	23	0.0448	0.0224
10	0.0812	0.0350	24	0.1218	0.0938
12	0.1568	0.1050	26	0.0490	0.0322
14	0.0868	0.042	29	0.0336	0.0154
15	0.1148	0.0560	30	0.1484	0.0700
16	0.0490	0.0252			

It is assumed that the investment cost of the capacitor is \$100/kVAR. Considering the interest rate $r = 0.05$, the capital recovery years $n=10$, the capital recovery factor (CRF) can be computed as $\alpha = 0.1295$. Thus, the cost of the capacitor (i.e., the fixed cost of VAR pricing on each VAR support bus) would be approximately \$35.48/MVAR/day, or \$3548/p.u.MVAR/day (base power is 100 MVA). The variable cost of VAR pricing for each reactive power support node is computed and listed in Table 2.3.

Table 2.3 Variable Cost of VAR Pricing for Each Load Node

Load node	VAR pricing \$/p.u.MVAR/day	Load node	VAR pricing \$/p.u.MVAR/day
2	0.0000	17	1231.7142
3	663.8671	18	2096.9999
4	640.7142	19	2210.1427
5	0.0000	20	3987.4283
7	767.9999	21	3911.9997
8	0.0000	23	4360.2854
10	966.4285	24	4778.5711
12	339.4285	26	5078.1425
14	1195.7142	29	4523.5711
15	1582.2856	30	5556.8568
16	953.5714		

It can be seen from the results that little benefit will be obtained if new VAR support is located at load buses #2, #3, #4, #5, #7, #8, #12 and #16 so these buses do not appear in the ranking of VAR source sites. The single hierarchical ranking is defined as that ranking obtained using only one of the three methods (BCR, SM or VSMM) for all elements in one hierarchical structure. The single hierarchical rankings are listed in Table 2.4. It can be observed from Table 2.4 that the same major candidate VAR support nodes are selected by the three methods, but that they differ in ranking order.

Table 2.4 Single Hierarchical Ranking of VAR Support Nodes

Node No.	BCR	Rank No.	SM	Rank No.	VSMM	Rank No.
10	0.272	13	3.135	12	0.398	12
14	0.337	12	2.860	13	0.338	13
15	0.446	10	3.137	11	0.518	10
17	0.347	11	3.199	10	0.410	11
18	0.591	9	3.951	9	0.705	8
19	0.623	8	4.105	8	0.767	6
20	1.124	6	8.041	6	0.647	9
21	1.103	7	7.713	7	0.754	7
23	1.229	5	8.094	5	1.293	4
24	1.347	3	8.582	4	2.290	5
26	1.431	2	10.58	2	5.136	2
29	1.275	4	10.40	3	5.005	3
30	1.566	1	10.73	1	7.848	1

Table 2-5 Judgment Matrix $PI_C - C$

Pic	C ₁₀	C ₁₄	C ₁₅	C ₁₇	C ₁₈	C ₁₉	C ₂₀	C ₂₁	C ₂₃	C ₂₄	C ₂₆	C ₂₉	C ₃₀
C ₁₀	1	3	1	2	3	1	1	1/2	1/2	1/3	1/3	1/2	1/3
C ₁₄	1/3	1	1/2	1/2	1	1/2	1/2	1/3	1/3	1/3	1/4	1/3	1/4
C ₁₅	1	2	1	2	3	2	2	1/2	1/3	1/3	1/3	1/3	1/3
C ₁₇	1/2	2	1/2	1	3	3	3	1	1/2	1/2	1/2	1/2	1/3
C ₁₈	1/3	1	1/3	1/3	1	1	1	1/3	1/3	1/3	1/4	1/3	1/4
C ₁₉	1	2	1/2	1/3	1	1	1	1/2	1/3	1/2	1/4	1/3	1/4
C ₂₀	1	2	1/2	1/3	1	1	1	1/2	1/3	1/2	1/3	1/3	1/4
C ₂₁	2	3	2	1	3	2	2	1	1/2	1/2	1/3	1/2	1/3
C ₂₃	2	3	3	2	3	3	3	2	1	2	1	2	1/2
C ₂₄	3	3	3	2	3	2	2	2	1/2	1	1/2	1	1/2
C ₂₆	3	4	3	2	4	4	3	3	1	2	1	2	1
C ₂₉	2	3	3	2	3	3	3	2	1/2	1	1/2	1	1/3
C ₃₀	3	4	3	3	4	4	4	3	2	2	1	3	1

To conduct the unified ranking of VAR source sites, it is necessary to comprehensively consider the results of three methods and the relative importance of VAR support buses. Thus, the judgment matrix $PI_C - C$ for the IEEE 30-bus system is given in Table 2.5, whose values reflect the relative importance in the power system between every pair of VAR support nodes. These

values have been selected according to the engineer’s knowledge and experience using the nine-ratio-scale method [53-55]. Figure 2.2 provides the unified ranking results of VAR support nodes, which coordinates BCR, SM and VSMM methods by using AHP for the IEEE 30-bus system. The unified ranking results in Figure 2.2 incorporate the relative importance of VAR support nodes in the power system from a decision-maker’s (or advisor’s) perspective. These tests indicate that this approach is a feasible method for VAR support placement.

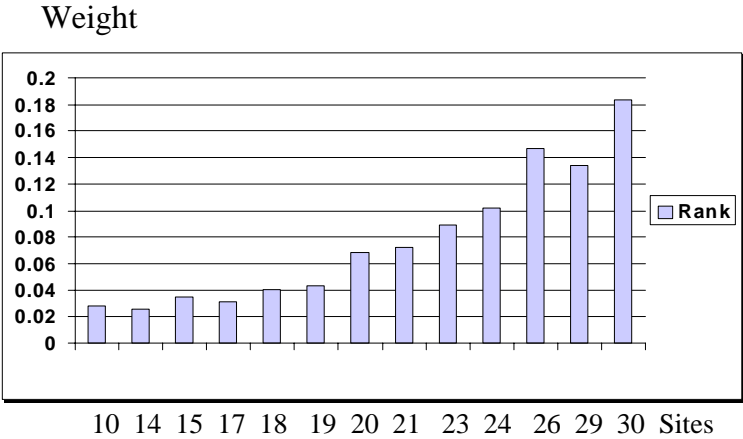

Figure 2.2 Unified Ranking of VAR Source Sites

NODAL PRICING OF REACTIVE POWER

3.1 Optimal Power Flow

One of the most fundamental aspects of electric power service is the control of customer voltage. Generator excitation systems, tap-changing-under-load (TCUL) transformers, and switched capacitors are the primary mechanisms for maintaining voltage levels to the distribution system. This section presents results on the use of an optimal power flow application for assessing the value of these voltage control services.

The optimal power flow (OPF) is a very large, non-linear mathematical programming problem whose solution techniques have evolved over many years. The majority of the techniques discussed in the literature use one of the following five methods:

- Lambda iteration method
- Gradient method
- Newton's method
- Linear programming method
- Interior point method.

This work employs the application of Newton's method to the OPF problem.

A power system OPF analysis can have many different goals and corresponding objective functions. One possible goal is to minimize the costs of meeting the load on a power system while maintaining system security. The relevant costs for a power system analysis will depend on the nature of the analysis; for the OPF analysis used in this work, the relevant costs are the costs of generating power (MW) at each generator. With an OPF analysis, satisfying a system security requirement means keeping the devices in a power system within a desired operation range at steady state. These ranges could include maximum and minimum outputs for generators, maximum MVA flows on transmission lines and transformers, and maximum and minimum system bus voltages. An OPF only addresses steady-state operation of the power system. Topics such as transient and dynamic stability are not addressed.

Another goal of an OPF analysis could be the determination of system marginal costs. This marginal cost data can aid in the pricing of MW transactions as well as in the pricing of ancillary services such as voltage support through MVAR support. In solving the OPF using Newton's method, the marginal cost data is determined as a by-product of the solution. A brief overview of the OPF solution method is given below.

A general minimization problem can be written in the following form:

$$\begin{aligned}
 &\text{Minimize } f_i(x) && \text{(the objective function)} \\
 &\text{subject to: } h_i(x) = 0, \quad i = 1, 2, \dots, m && \text{(equality constraints)} \\
 & && g_j(x) \leq 0, \quad j = 1, 2, \dots, n && \text{(inequality constraints)}
 \end{aligned} \tag{3-1}$$

There are m equality constraints and n inequality constraints. The number of variables is equal to the dimension of the vector x . The solution of this problem by Newton's method requires the creation of the Lagrangian:

$$\begin{aligned}
 L(z) = f(x) + \mu h(x) + \lambda g(x) &= \text{the lagrangian} \\
 \text{where } z = [x \quad \mu \quad \lambda]^T, & \\
 \text{and } \mu \text{ and } \lambda &\text{ are vectors of lagrange multiplier,} \\
 \text{and } g(x) &\text{ only includes the active (or binding)} \\
 &\text{inequality constraints}
 \end{aligned} \tag{3-2}$$

A gradient and Hessian of the Lagrangian may then be defined as:

$$\text{gradient} = \nabla L(z) = \left[\frac{\partial L(z)}{\partial z_i} \right] \tag{3-3}$$

$$\begin{aligned}
 \text{Hessian} = \nabla^2 L(z) = \mathbf{H} &= \left[\frac{\partial^2 L(z)}{\partial z_i \partial z_j} \right] = \\
 &\begin{bmatrix} \frac{\partial^2 L(z)}{\partial x_i \partial x_j} & \frac{\partial^2 L(z)}{\partial x_i \partial \mu_j} & \frac{\partial^2 L(z)}{\partial x_i \partial \lambda_j} \\ \frac{\partial^2 L(z)}{\partial \mu_i \partial x_j} & 0 & 0 \\ \frac{\partial^2 L(z)}{\partial \lambda_i \partial x_j} & 0 & 0 \end{bmatrix}
 \end{aligned} \tag{3-4}$$

The OPF solution is obtained by solving $\nabla L(z) = 0$. The Hessian is used in the iterative process of Newton's method.

Special attention must be paid to the inequality constraints of the problem. As noted above, the Lagrangian only includes those inequalities that are being enforced. For example, if a bus voltage is within the desired operating range, then there is no need to activate the inequality constraint associated with that bus voltage. For this Newton's method formulation, the inequality constraints are handled by separating them into two sets: active and inactive.

The objective function for the OPF reflects the costs associated with generating power in the system. The following quadratic cost model for generation of power was utilized:

$$C(P_{Gi}) = a_i + b_i P_{Gi} + c_i P_{Gi}^2 \tag{3-5}$$

where P_{Gi} is the amount of generation in MW at generator i . The objective function for the entire power system can then be written as the sum of the quadratic cost model for each generator.

$$f(x) = \sum_i (a_i + b_i P_{Gi} + c_i P_{Gi}^2) \quad (3-6)$$

Using this objective function in the OPF will minimize the total system costs. This does not necessarily minimize the costs for a particular area within the power system. In general, in well-functioning competitive market, the system should reach this minimum point through transactions.

The equality constraints of the OPF reflect the physics of the power system as well as desired set points throughout the system. The physics of the power system is enforced through the power flow equations that require that the net injection of real and reactive power at each bus sum to zero:

$$\begin{aligned} P_k = 0 &= V_k \sum_{m=1}^N [V_m [g_{km} \cos(\delta_k - \delta_m) + b_{km} \sin(\delta_k - \delta_m)]] - P_{Gk} + P_{Lk} \\ Q_k = 0 &= V_k \sum_{m=1}^N [V_m [g_{km} \sin(\delta_k - \delta_m) - b_{km} \cos(\delta_k - \delta_m)]] - Q_{Gk} + Q_{Lk} \end{aligned} \quad (3-7)$$

It is common for the power system operators to have voltage set-points for each generator. In this case, an equality constraint for each generator is added.

$$V_{Gi} - V_{Gisetpoint} = 0 \quad (3-8)$$

Finally, for multi-area power systems, a contractual constraint requires that the net power interchange be equal to the scheduled power interchange. This adds an equality constraint for all but one area.

$$P_{\text{interchange}} - P_{\text{scheduled interchange}} = \sum_{\text{tie lines}} [P_{km}] - P_{\text{scheduled interchange}} = 0 \quad (3-9)$$

This last area must not have the equality constraint and essentially becomes what can be called a “slack” area. The inequality constraints of the OPF reflect limits on physical devices in the power system as well as limits created to ensure system security. Physical devices and their limitations include generator power outputs, TCUL transformer tap values, and phase-shifting transformer tap values.

For the maintenance of system security, power systems have MVA ratings on transmission lines and transformers. The constraint used in this OPF formulation will limit the square of the MVA flow on a transformer or transmission line. The square of the MVA flow is used to make derivative calculations in Newton’s method easier.

$$|S_{km}|^2 - |S_{km \max}|^2 \leq 0 \quad (3-10)$$

For quality of electrical service and the maintenance of system security, bus voltages usually have maximum and minimum magnitudes. These limits require the addition of inequality constraints.

$$V_{i \min} \leq V_i \leq V_{i \max} \quad (3-11)$$

The OPF is able to model system security issues including line overloads, and low-voltage and high-voltage problems. Besides performing these enhanced engineering functions, the OPF also yields information concerning the economics of the power system. The Lagrange multiplier associated with each constraint can be interpreted as the marginal cost associated with meeting that constraint. Therefore, the Lagrange multipliers, μ_{P_k} and μ_{Q_k} , can be interpreted as the marginal cost of real and reactive power generation at bus k in \$/MWhr and \$/MVARhr respectively. These marginal costs could then be used to determine electricity spot prices at bus k . On a larger level, the Lagrange multiplier associated with the area interchange constraint can be seen as the marginal cost of the area relaxing its interchange constraint. If this cost is positive, then the area would benefit from buying electricity, while if it is negative, the area would benefit from selling electricity. These costs may be of use in determining the price which one area would charge for a MW transaction with another area.

3.2 Value of a Reactive Power Source: The Capacitor Bank

The three-bus system of Figure 3.1 (data in Tables 3.1 to 3.3) was used to illustrate and examine the value of reactive power support at a system load bus.

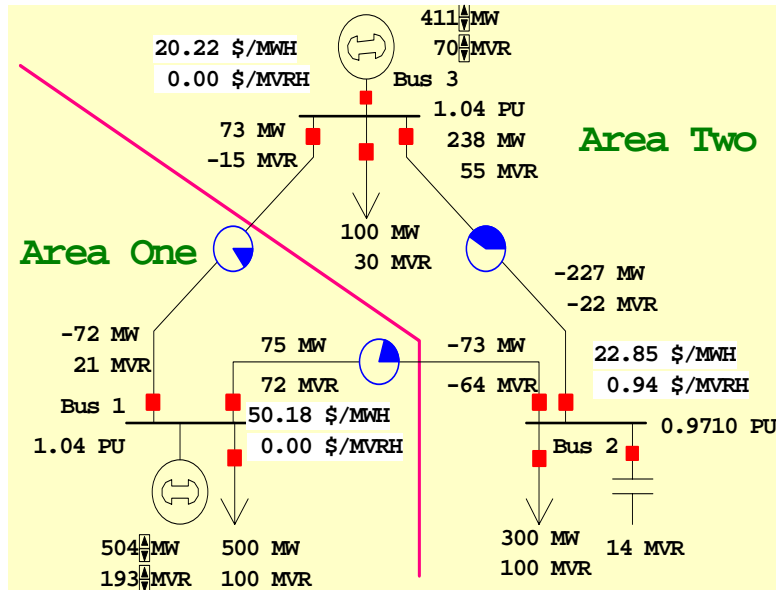

Figure 3.1 Three-bus base case with no area power transfer

Table 3.1 Line characteristics for a 3-bus system

From Bus	To Bus	R [p.u.]	X [p.u.]	C [p.u.]	Limit [MVA]
1	2	0.02	0.08	0.00	500
1	3	0.03	0.12	0.00	500
2	3	0.02	0.06	0.00	600

Table 3.2 Bus characteristics for a 3-bus system

Bus Number	Load [MW]	Load [MVAR]	Min Gen. [MW]	Max Gen. [MW]
1	500	100	100	800
2	300	100	0	0
3	100	30	100	800

Table 3.3 Economic information for a 3-bus system

Generator Bus	a $\left[\frac{\$}{\text{hr}}\right]$	b $\left[\frac{\$}{\text{MW hr}}\right]$	c $\left[\frac{\$}{\text{MW}^2 \text{ hr}}\right]$
1	100	25.0	0.0250
3	150	13.0	0.0100

Area One consists only of the generator and load at bus 1 plus two tie lines. Area Two consists of the generator and load at bus 3 plus the load at bus 2, and the line from bus 2 to bus 3. Area One has expensive generation, while Area Two has cheaper generation. For the indicated loads and no area transfers the cost of operation for the total system is \$25,799/hr. For this study, the loads at all buses remain fixed at the values shown.

The base case shown in Figure 3.1 has each area providing its own load plus a portion of the system losses. The unfilled pie charts on each line indicate that the lines are loaded at less than their MVA ratings. This base case has zero scheduled MW transfer between the two areas, but 73 MW of Area Two's generation flows through Area One.

Note that the incremental cost for reactive power at a generator bus is \$0.00. This is true as long as no MVAR limits are reached because there is no cost of generating MVARs in this OPF formulation.

Area One wants to purchase power at considerable savings from Area Two. Similarly, Area Two wants to sell power to Area One. We first examine the available transfer capability of this system for transfer from Area Two to Area One. An OPF solution with bus voltage constraints is

used to find the maximum power that can be transferred from Area Two to Area One. The voltage constraint for power quality used in this example is:

$$0.96 \leq V_i \leq 1.04 \quad (3-12)$$

Both generators have their excitations set to give 1.04 p.u. voltage for serving their local area load within the voltage constraints. A global OPF solution that minimizes the total cost of serving the load will attempt to increase Area Two generation and decrease Area One generation. This power transfer will change the voltage at bus 2. When the transfer is such that the voltage reaches its lower limit (0.96 p.u.), the OPF solution will stop at that constraint. The solution and associated marginal costs for both real and reactive power at each bus are shown in Figure 3.2 for the case where a nominal 15 MVAR capacitor bank is installed at bus 2 for reactive power support. The available transfer capability for these constraints is 244 MW. The cost of operation for the total system is \$21,341/hr. Thus, this maximum power transfer has resulted in a reduction of total cost by \$4,458/hr. Additional transfers are not possible without violation of the voltage constraint at bus 2. Due to the voltage constraint, the incremental cost for MVARs is almost the same as for MWs at bus 2.

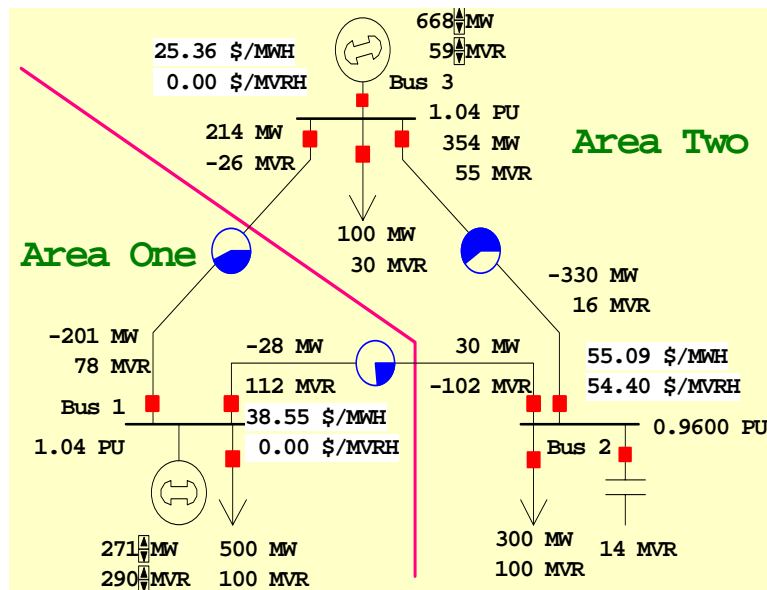

Figure 3.2 Three-bus example at maximum power transfer (15 MVAR capacitor support)

When the capacitor bank at bus 2 is increased from a nominal 15 MVAR rating to a nominal 30 MVAR rating, the OPF solution is given in Figure 3.3. The available transfer capability for these constraints is increased to 325 MW. The cost of operation for the total system is \$20,890/hr. Thus, the increase in available transfer capability has resulted in an additional reduction of total cost by \$451/hr. Again, additional power transfers are not possible without violation of the voltage constraint at bus 2. Note that the incremental cost for MVARs has reduced as the OPF approaches a more economical dispatch.

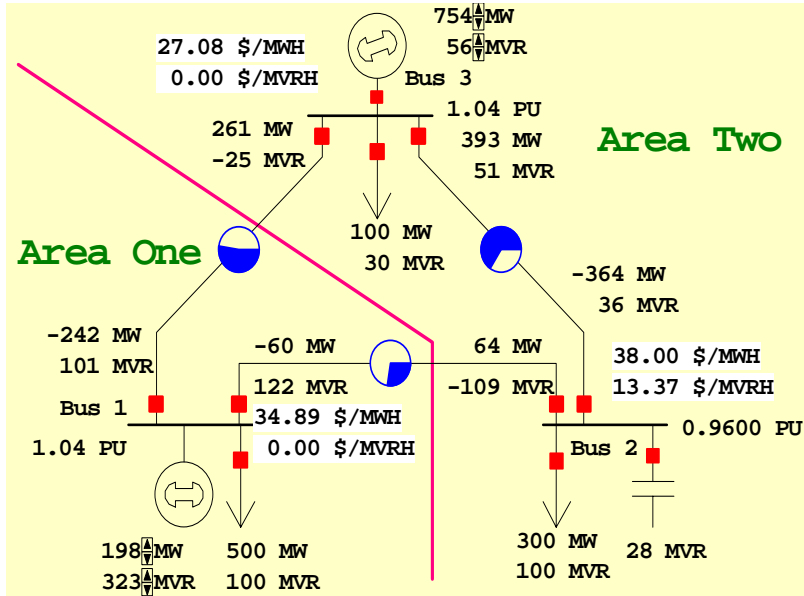

Figure 3.3 Three-bus example at maximum power transfer (30 MVAR capacitor support)

When the capacitor bank at bus 2 is increased from a nominal 30 MVAR rating to a nominal 45 MVAR rating, the OPF solution is given in Figure 3.4. The available transfer capability for these constraints is increased to 355 MW. The cost of operation for the total system is \$20,849/hr. Thus, the increase in available power transfer capability has resulted in a further reduction of total cost by \$41/hr. The OPF has reached an optimal dispatch schedule without reaching the bus 2 voltage constraint (since $0.963 > 0.96$). Therefore, no additional power transfers can lower the total system costs.

The savings between 15 and 30 MVAR capacitors was \$451 while the savings between 30 and 45 MVAR capacitors was only \$41. This is because there is a greater change in system MW dispatch when moving from 15 to 30 MVAR than from 30 to 45 MVAR. This is also reflected in the incremental costs of MVAR at bus 2 for the various cases.

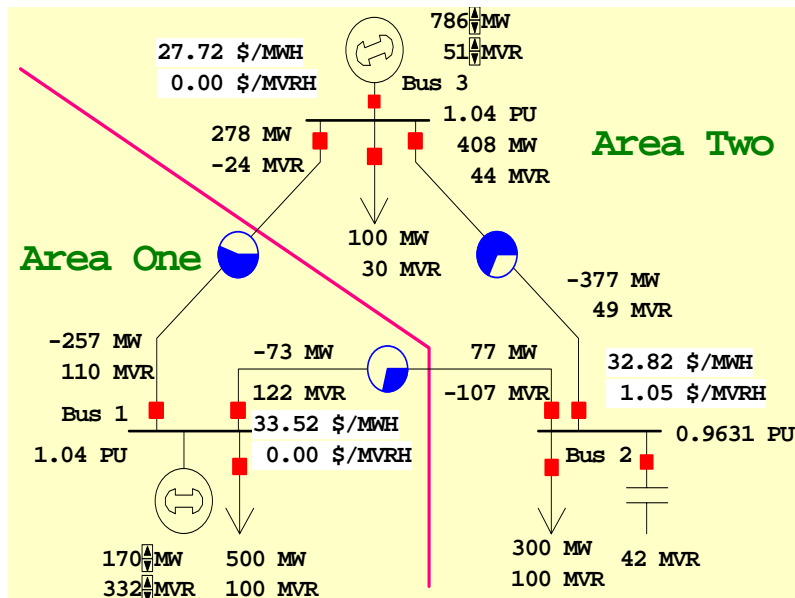

Figure 3.4 Three-bus example at maximum power transfer (45 MVAR capacitor support)

4

THIRD-PARTY REACTIVE POWER SUPPORT ISSUES

This Chapter examines several issues associated with transactions and associated third-party impacts in power systems. The issues of voltage support and margin to voltage collapse are addressed to provide an understanding of the system concerns in economic operation of and transactions in an interconnected system. Small example systems are used to clearly illustrate causes and effects.

4.1 Costing and Pricing of Voltage Support

As a base case, the 3-bus system in Figure 4.1 has an unity power factor load and no real power transfers. There are no reactive power requirements from any of the three generators because each interconnected bus has the same set-point voltage and there are no real power transfers.

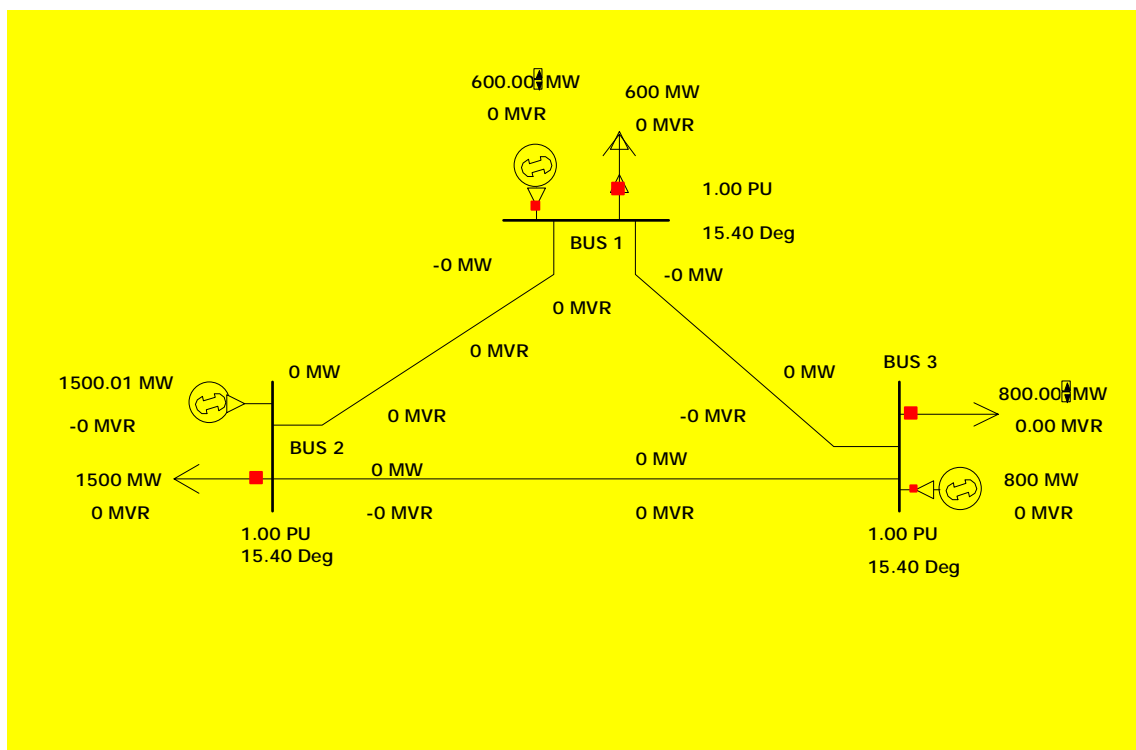

Figure 4.1 Three bus base-case example

Now, we assume that the real power generation at bus 1 is cheaper than that of bus 2. Using the transmission system, a 1,000 MW transaction from bus 1 to bus 2 is executed as shown in Figure 4.2.

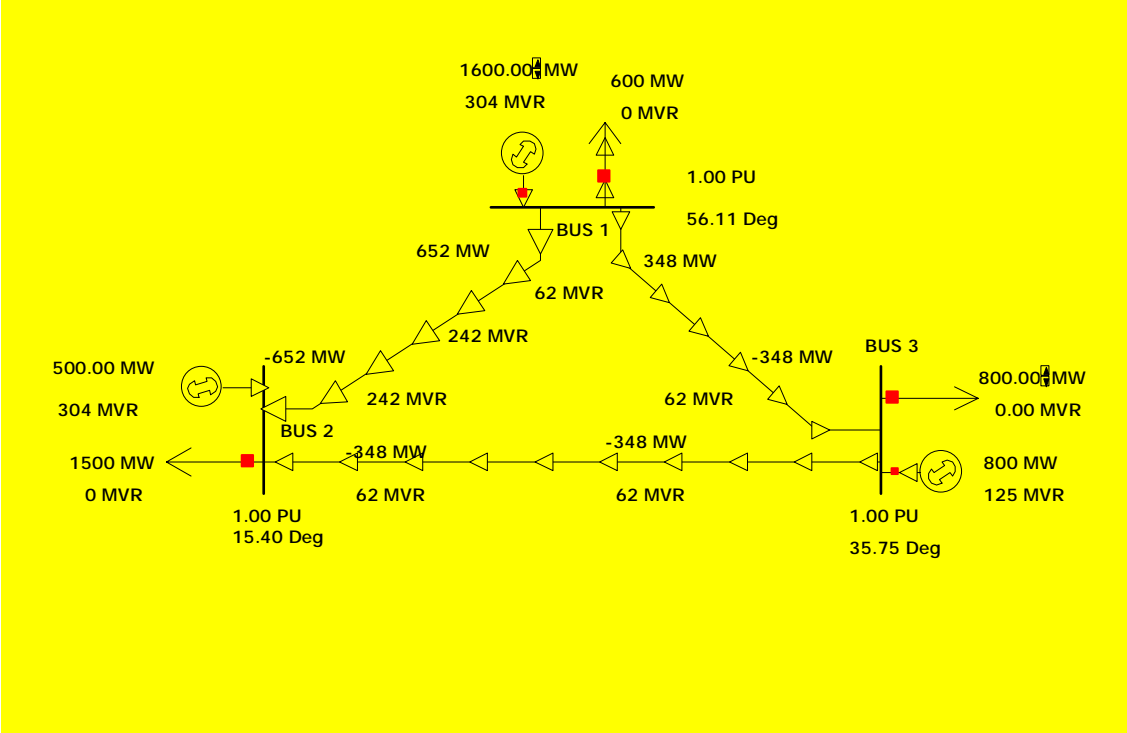

Figure 4.2 System with a transaction and full VAR support

To hold the voltage at 1.0 p.u. at each bus, the generators need to produce reactive power support of 304, 304, and 125 MVAR at buses 1, 2, and 3 respectively. Even though the generator at bus 3 is not involved in the transaction, it has to provide VARs to support the transaction.

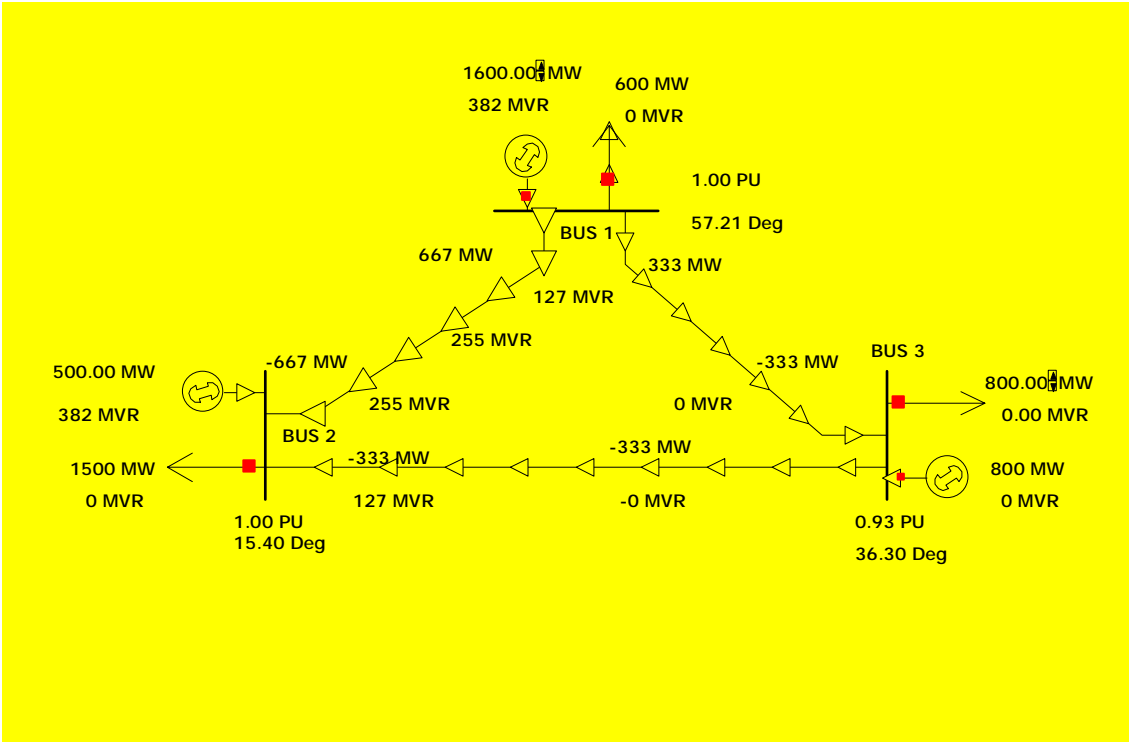

Figure 4.3 System with a transaction and partial VAR support

Figure 4.3 shows the impact of withholding VAR support at bus 3. Without the reactive power support from the generator at bus 3, the voltage at bus 3 drops to an unacceptable level of 0.93 p.u.

Actually, the larger the transaction, the larger the amount of reactive power support required from the generator at bus 3. In other words, without VAR support from the generator at bus 3, increasing the transaction from bus 1 to bus 2 lowers the voltage at bus 3.

Another option for maintaining a satisfactory voltage at bus 3 rather than using reactive power support from the generator at bus 3 is to set the voltage at bus 1 higher than 1.0 p.u. The power flow results in Figure 4.4 show that to return the voltage at bus 3 from 0.93 back to 1.0 p.u. after the transaction, the generator at bus 1 has a voltage set-point of 1.11 p.u.

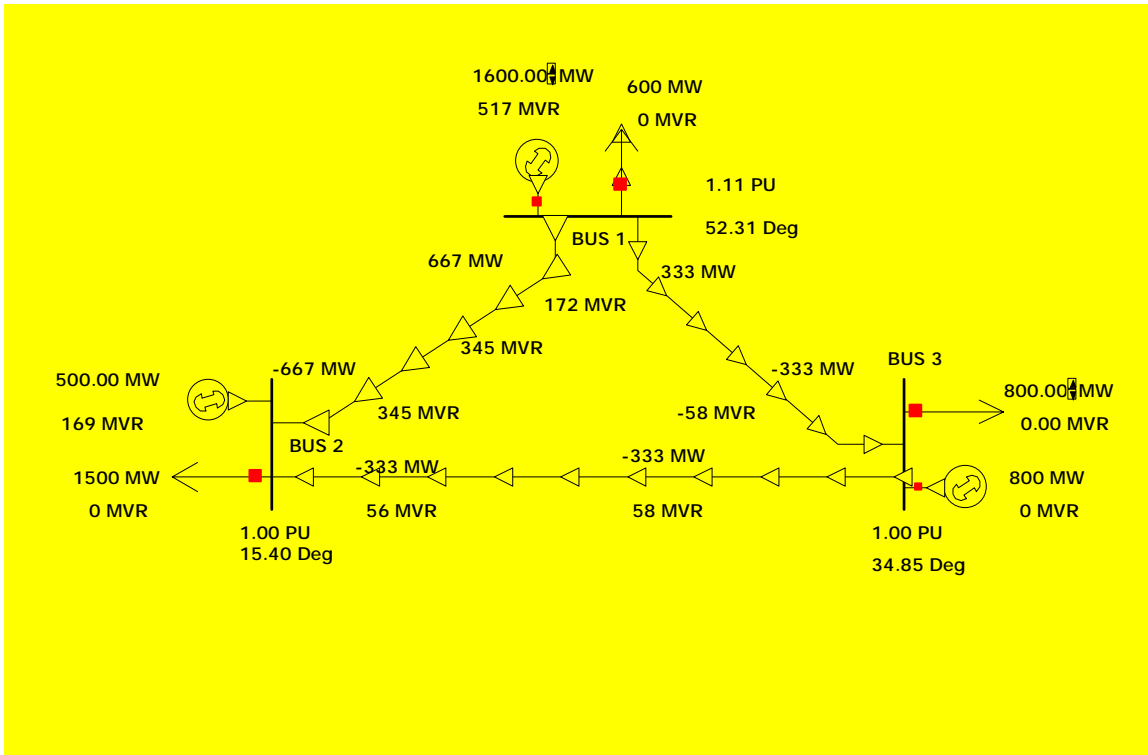

Figure 4.4 System with remote VAR support

Hence, the reactive power support should be provided at the place where it is most needed. In this example, the reactive power support by the generator at bus 3 is the best way to improve the voltage at bus 3.

Providing voltage support can create opportunity costs or lost profit if power output must be reduced to meet a voltage support requirement. This possibility occurs because operation of a generator is subject to a generator PQ capability constraint, as illustrated in Figure 4.5. Different physical constraints determine the shape of the capability constraint curve. The real and reactive power production of the generator is constrained by the field current limit (segment a-b), the armature current limit (segment b-c) and the under-excitation limit (segment c-d). Although not shown in Figure 4.5, there can also be a minimum power output that will affect the constraint curve. To illustrate the effects of the generator PQ capability constraint, we will examine the economic impact if the generator at bus 3 is used to provide the required reactive power support at bus 3. We assume that the generator at bus 3 is serving the 800 MW load at bus 3. We further assume that its marginal cost is constant at \$6/MWh, and the price of real power at bus 3 is \$10/MWh. Hence, the generator's marginal profit is \$4/MWh and its total "contribution" to profit (that is, ignoring fixed operating costs) from real power production is $4 \times 800 = \$3200$.

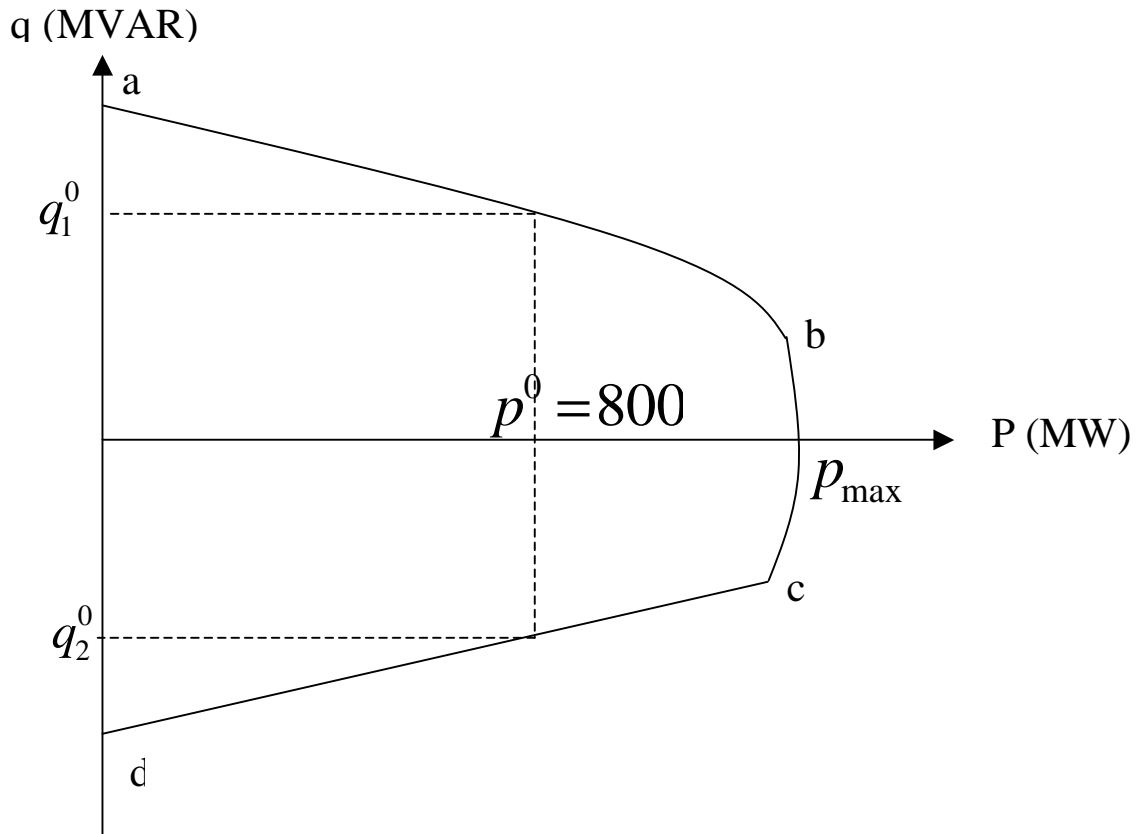

Figure 4.5 Generator PQ Capability Constraint Curve

We will assume that the generator's PQ capability constraint curve is as shown in Figure 4.5. The generation's 800 MW output determines that it can at most produce q_1^0 MVAR or absorb q_2^0 MVAR. Hence, if the reactive power requirement is larger than q_1^0 , then active power generation has to be reduced. As shown in Figure 4.6, if \hat{q}_1 MVAR output is needed to keep the bus 3 voltage at 1.0 p.u., then generation at bus 3 must change to the new operating point (\hat{p}, \hat{q}_1) . Thus, the generation at bus 3 has to reduce its MW generation by

$$\Delta p = p^0 - \hat{p}$$

The reduction has to be picked up by some other generator. In this example, it is the generator at bus 2.

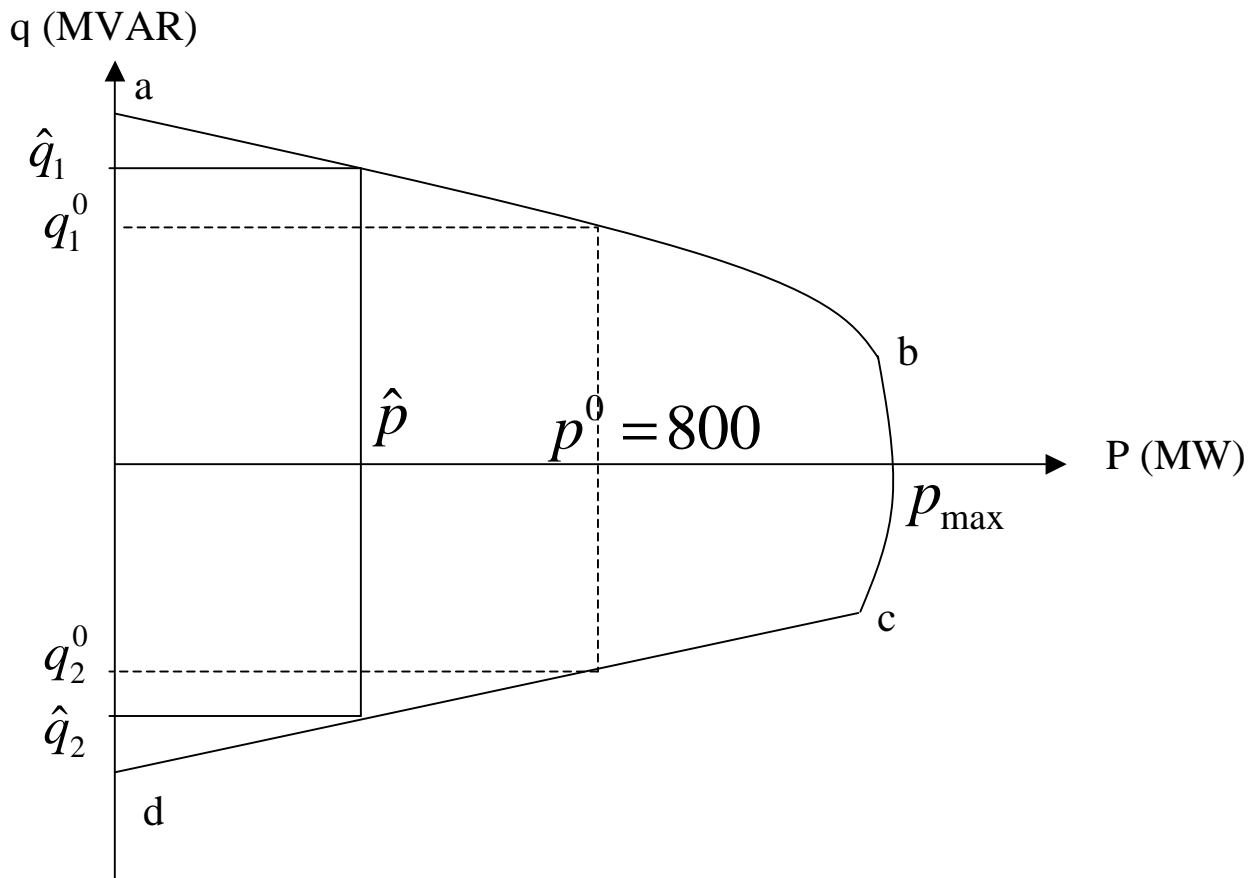

Figure 4.6 Generator PQ Capability Constraint Curve Operation

The lost profit for the generator at bus 3 in its MW production is

$$\Delta\pi = \Delta p * 4$$

The power flow results given in Figure 4.7 show that

$$\hat{p} = 700 \text{ MW}, \hat{q}_1 = 100 \text{ MVAR}$$

The generator loses \$400 in the real power production in order to provide 100 MVAR reactive power support. We call these \$400 the opportunity cost of the reactive power support.

To keep the owner of the generator at bus 3 from losing profit by providing voltage support, a payment of at least \$400 will have to be made for the voltage support. The owner of the generator will be indifferent to producing 800 MW and 0 MVAR or 700MW and 100 MVAR, if this compensation payment is made.

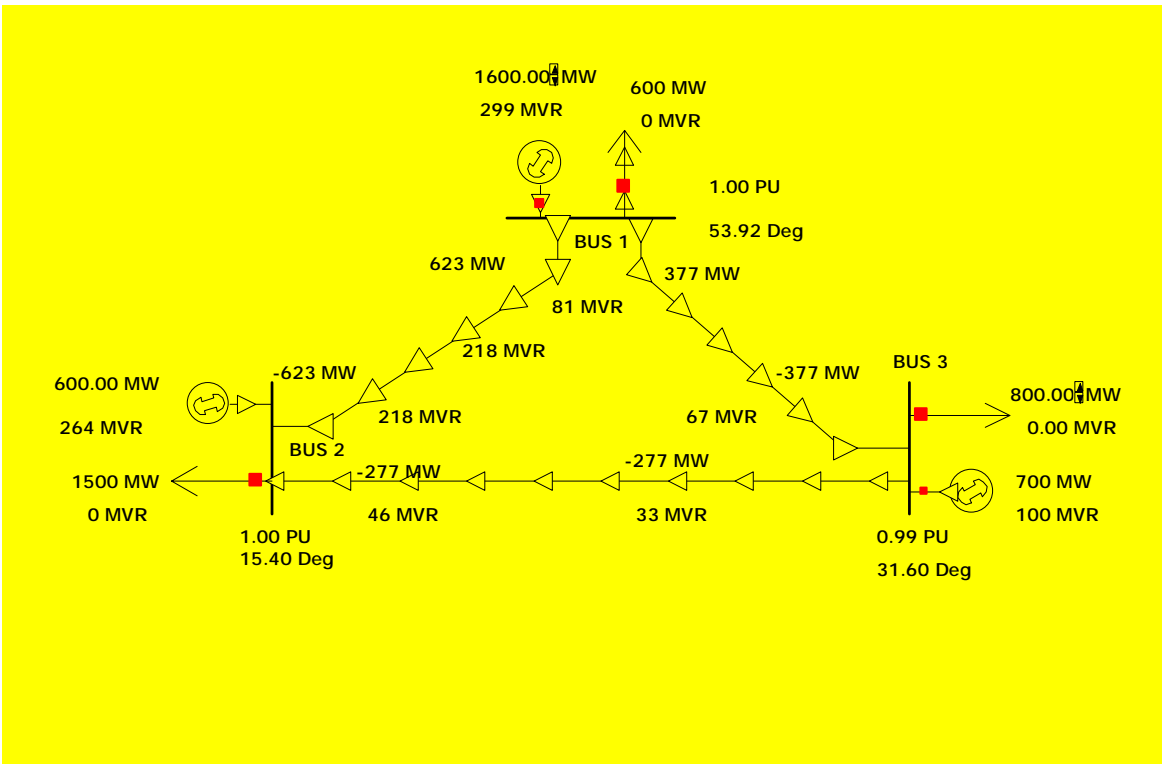

Figure 4.7 System flows with real-power redispatch

4.2 Sensitivity of the Margin to Voltage Collapse

Reactive power is needed to increase the loadability of a network. In this section, loadability is characterized by the closeness of a network to voltage collapse. The five area system shown in Figure 4.8 was investigated to understand the significance of third-party reactive power support of transactions and the sensitivity of voltage collapse margins to reactive power reserves. This base case shows all five areas to be supplying their own unity-power-factor loads and maintaining 1.0 per unit voltage. As such, none of the areas is producing any reactive power. Alternatively, this base case could be thought of as each area supplying exactly the amount of reactive power required within each area (in other words, each area is a bus in this case).

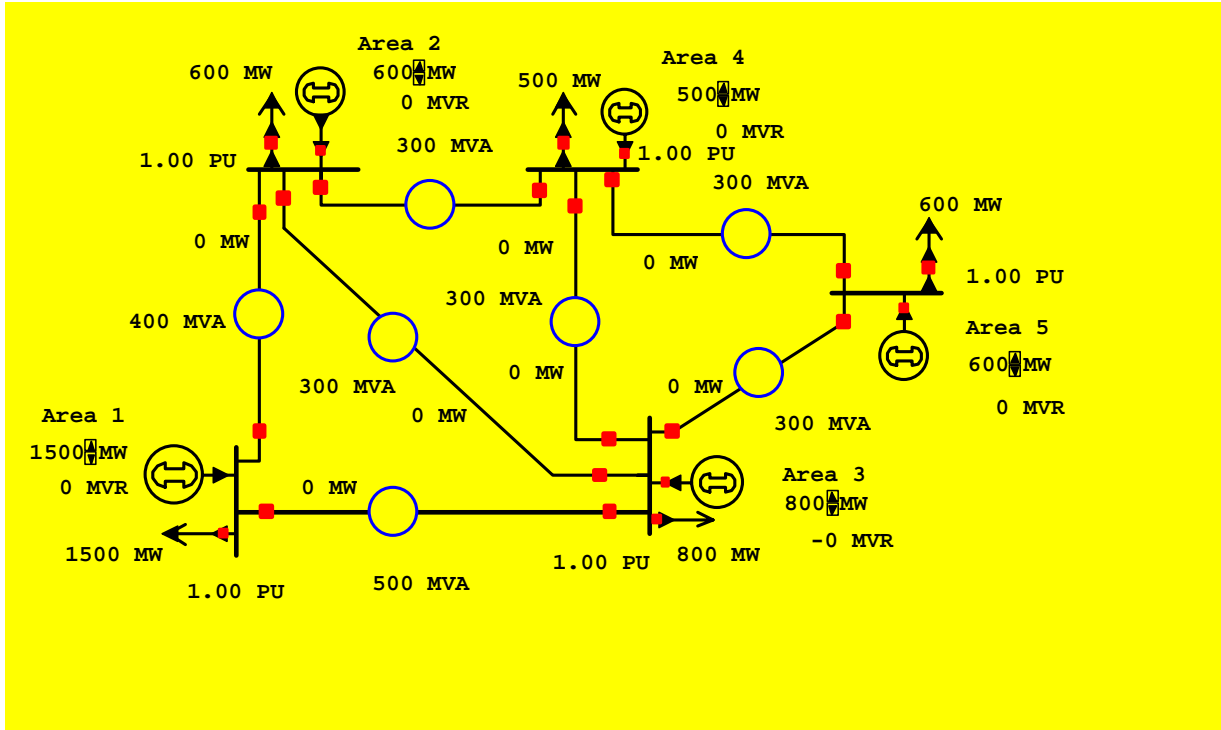

Figure 4.8. Five-Area Illustration base case - zero real power transfers

We begin by examining a possible transaction of real power from Area 1 to Area 5. Table 4.1 shows the sensitivity of reactive power requirements to real-power transfers ranging from 0.2 MVAR/MW at low levels to nearly 3.0 at the highest level. This assumes unlimited supplies of reactive power in each area and yields an absolute maximum real power transfer from Area 1 to Area 5 of 381 MW. This maximum condition is shown in Figure 4.9. One additional MW of real power transfer from Area 1 to Area 5 will result in total system collapse.

Table 4.1 Reactive power required to support real-power transfer from Area 1 to Area 5

P(1 to 5) MW	Area 1 MVAR	Area 2 MVAR	Area 3 MVAR	Area 4 MVAR	Area 5 MVAR	Total MVAR
50	3	1	4	1	2	11
100	13	4	15	5	9	46
150	31	10	34	12	21	108
200	57	18	62	21	38	196
250	93	29	100	33	61	316
300	146	45	154	50	91	486
331	194	50	200	62	114	620
350	230	71	234	70	128	733
381	362	110	342	86	156	1,056

The table clearly illustrates the critical nature of third-party reactive power support and how this support must be obtained as an ancillary service to accompany the transfer of real power from Area 1 to Area 5. Area 3 has the highest sensitivity and is called upon to provide the largest amount of reactive power.

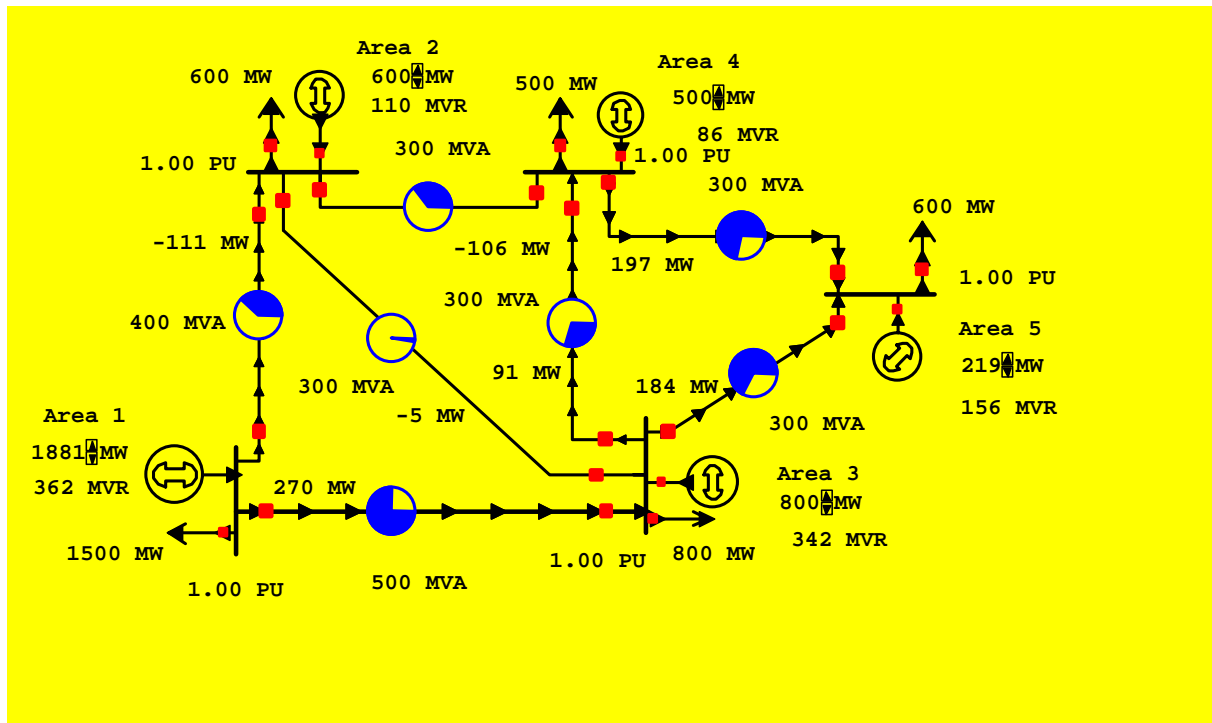

Figure 4.9. Five-Area Illustration - maximum real-power transfer from Area 1 to Area 5.

The amount of third-party reactive power support to push the transfer to its maximum requires the following MVAR from Areas 2, 3 and 4: 110, 342, and 86. If the transfer is limited to 331 MW so that there is a 50 MW voltage collapse margin (with respect to this transfer), the third-party reactive power support requirements from Areas 2, 3, and 4 are: 60, 200, and 52 MVARs. The MVARs needed to ensure the 50 MW collapse margin are the original 110, 342, and 86. Thus, while only these smaller amounts are needed to support the transaction, the larger amounts are needed to ensure the margin to system collapse (with respect to this transaction).

To see the impact of reactive power limitations on generation, we consider the case where Area 3 is limited by initial reactive power reserves of 300 MVAR. This case is shown in Table 4.2 where the maximum possible transfer is reduced to 375 MW (with the resulting system conditions given Figure 4.10). This maximum real-power transfer condition occurred exactly when the Area 3 reactive power supply capability was reached. Thus, the system voltage collapse margin is zero when the Area 3 reactive-power limit is reached. For limits greater than 300 MVAR, the system will collapse at the same time the reactive power limit is reached. For limits smaller than 300 MVAR, the system will collapse at a transfer level greater than the transfer level at the time the reactive power limit is reached. An example of this result is illustrated below.

Table 4.2 Reactive power required to support real-power transfer from Area 1 to Area 5 when Area 3 reactive power capability is limited to 300 MVAR

P(1 to 5) MW	Area 1 MVAR	Area 2 MVAR	Area 3 MVAR	Area 4 MVAR	Area 5 MVAR	Total MVAR
50	3	1	4	1	2	11
100	13	4	15	5	9	46
150	31	10	34	12	21	108
200	57	18	62	21	38	196
250	93	29	100	33	61	316
300	146	45	154	50	91	486
350	230	71	234	70	128	733
375	318	98	300	87	152	955

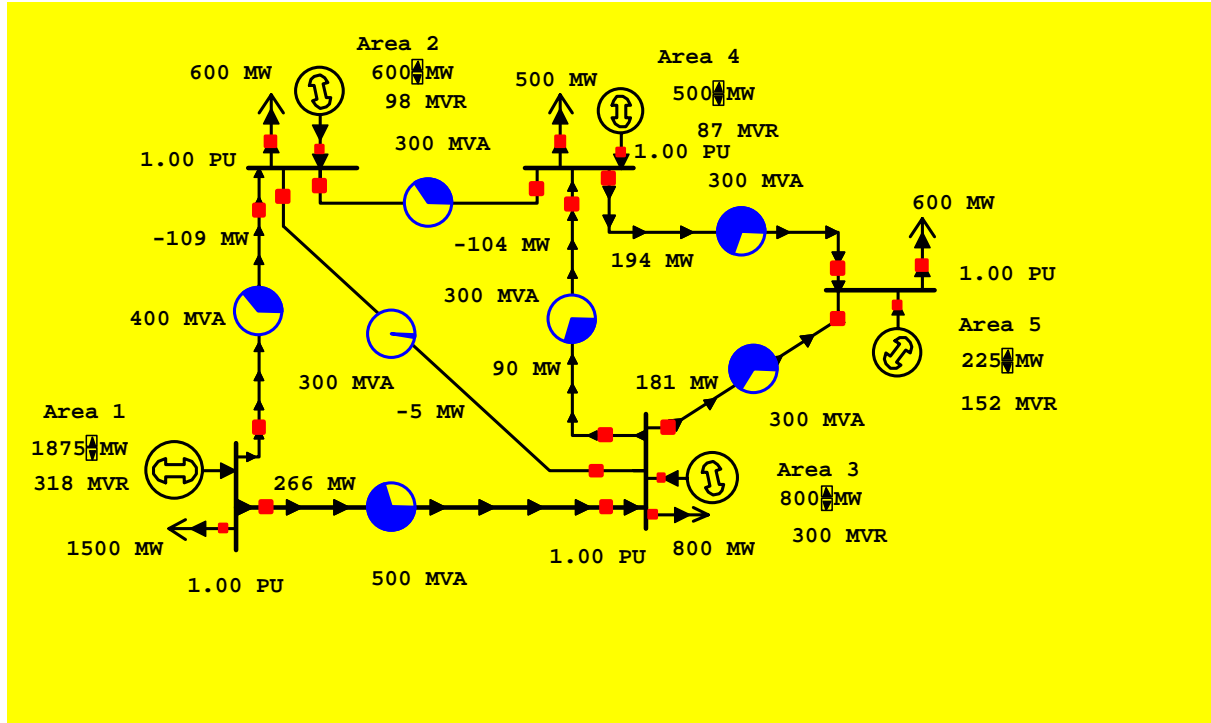

Figure 4.10 Five-Area Illustration - maximum real-power transfer from Area 1 to Area 5 (with Area 3 reactive capability limited to 300 MVAR).

Now we consider the case where Area 3 initially has only 150 MVAR of reactive reserves. This case is shown in Table 4.3 where the maximum possible real-power transfer from Area 1 to Area 5 is reduced to 356 MW. The power flow results are given in Figure 4.11. At this maximum, the voltage in Area 3 has dropped to 0.92 per unit. The point of maximum transfer did not occur when Area 3 hit its reactive power capability limit. The Area 3 limit occurred when the transfer was 300 MW. In terms of the transfer from Area 1 to Area 5, the system collapse margin is over 50 MW when Area 3 exhausts its reactive power support capability.

Table 4.3 Reactive power required to support real-power transfer from Area 1 to Area 5 when Area 3 reactive power capability is limited to 150 MVAR.

P(1 to 5) MW	Area 1 MVAR	Area 2 MVAR	Area 3 MVAR	Area 4 MVAR	Area 5 MVAR	Total MVAR
50	3	1	4	1	2	11
100	13	4	15	5	9	46
150	31	10	34	12	21	108
200	57	18	62	21	38	196
250	93	29	100	33	61	316
300	147	46	150	52	91	486
350	275	104	150	132	147	808
356	325	126	150	158	159	918

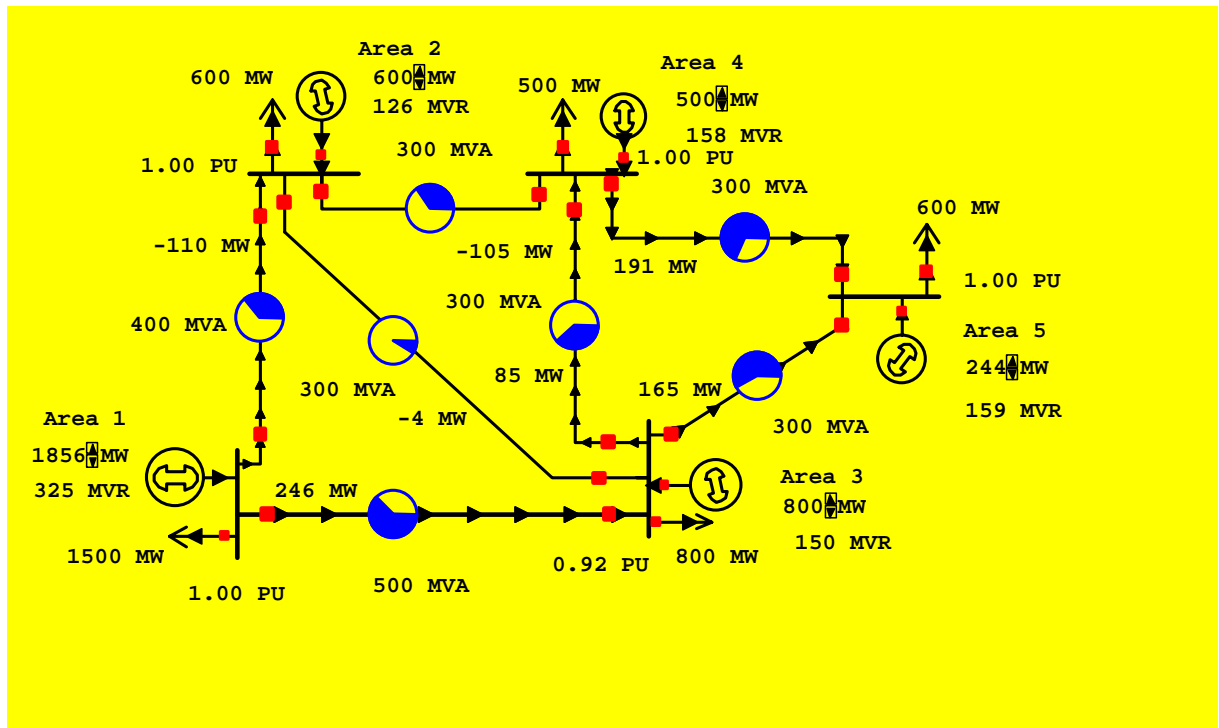

Figure 4.11 5-Area Illustration - maximum real-power transfer from Area 1 to Area 5 (with Area 3 reactive capability limited to 150 MVAR).

5

REACTIVE POWER LOSS ALLOCATION

To investigate the issues of costing and pricing the reactive power requirements for real-power transactions, it is necessary to examine the allocation of reactive power losses. This section compares various possible approaches to the allocation of reactive power losses created by multiple real-power transactions.

Base Case Example System

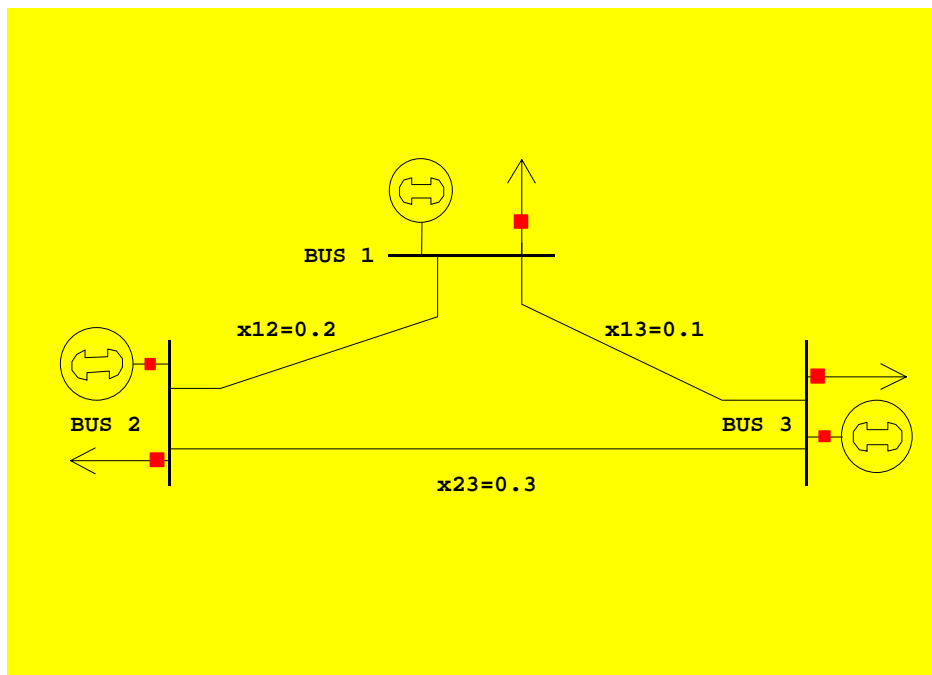

Figure 5.1 Example system

In this three-bus example, each bus represents a single area as shown in Figure 5.1. Each area has its own generation and load, and the system has zero line resistance. The impedance of the transmission lines between bus 1 and 2, bus 1 and 3, and bus 2 and bus 3 are:

$$x_{12} = 0.2 \text{ p.u.}$$

$$x_{13} = 0.1 \text{ p.u.}$$

$$x_{23} = 0.3 \text{ p.u.}$$

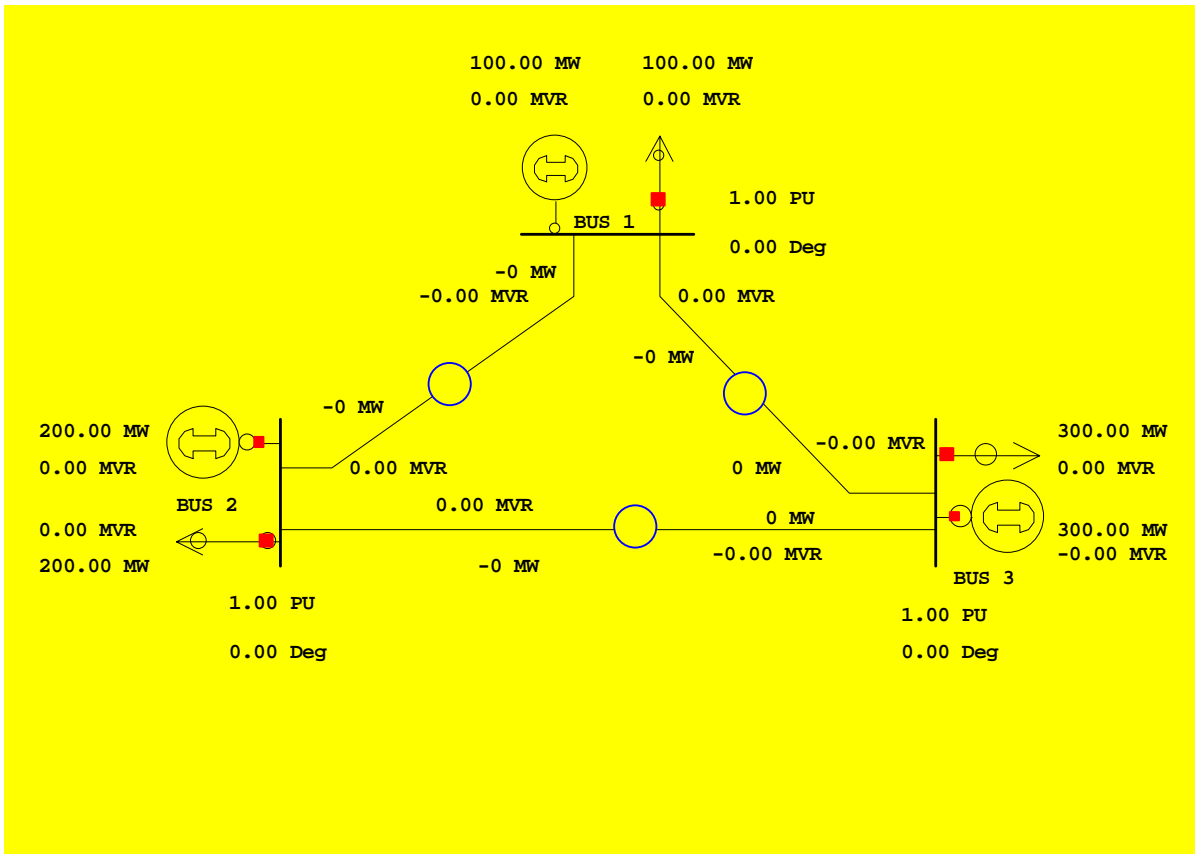

Figure 5.2 Example system base case

In the base case, the MW generation and load at each bus is balanced and there are no transactions between areas as shown in Figure 5.2. We assume that each bus voltage is 1.0 p.u. and that each load is unity power factor. Under these conditions, the base case has zero reactive power requirements in each area, and zero reactive power losses in the transmission system.

Example System with Transaction 1

We now assume that generation at bus 2 is cheaper than the generation at bus 1, so that the load at bus 1 purchases 50MW from the generator at bus 2 as shown in Figure 5.3. We call this transaction 1. To implement transaction 1, the MW output at bus 2 is increased from 200 MW to 250 MW, and the MW output of the generator at bus 1 is decreased from 100 MW to 50 MW. All other generations and loads remain fixed, and the generator voltage at each bus is still set to 1.0 p.u. The power flow given in Figure 5.3 shows that with transaction 1 on the system, the reactive power generation of each generator is

$$Q_1^1 = 1.25 \text{ MVAR}, Q_2^1 = 1.53 \text{ MVAR}, Q_3^1 = 0.56 \text{ MVAR}$$

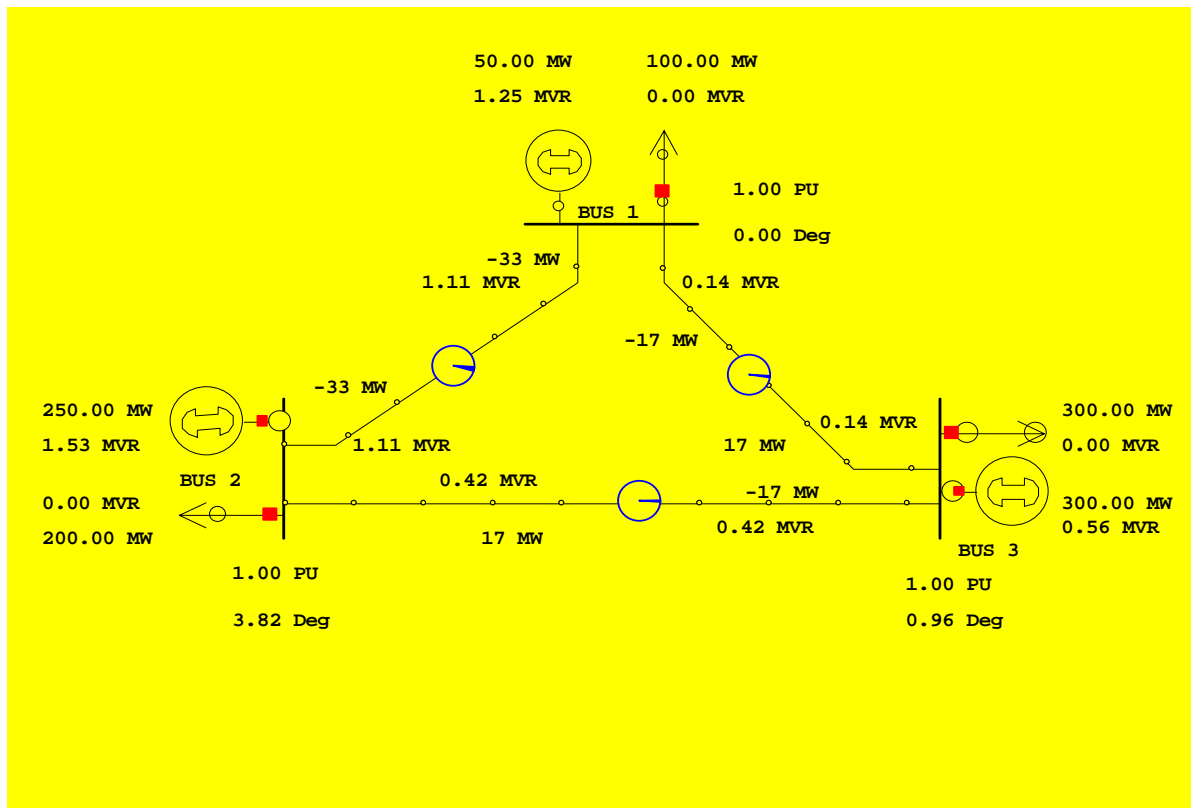

Figure 5.3 Example system with transaction 1

Example System with Transaction 2

We now return to the base case and assume a transaction from Area 2 to Area 3 as shown in Figure 5.4. We increase the generation by 100 MW at bus 2 and decrease the generation by 100 MW at bus 3, while all other generation and loads are fixed at their values at the base case. The generator voltage at each bus is still set to 1.0 p.u. The power flow results show that in the case of the base case plus transaction 2, the reactive power output at each bus is

$$Q_1^2 = 3.77 \text{ MVAR}, Q_2^2 = 6.28 \text{ MVAR}, Q_3^2 = 5.01 \text{ MVAR}$$

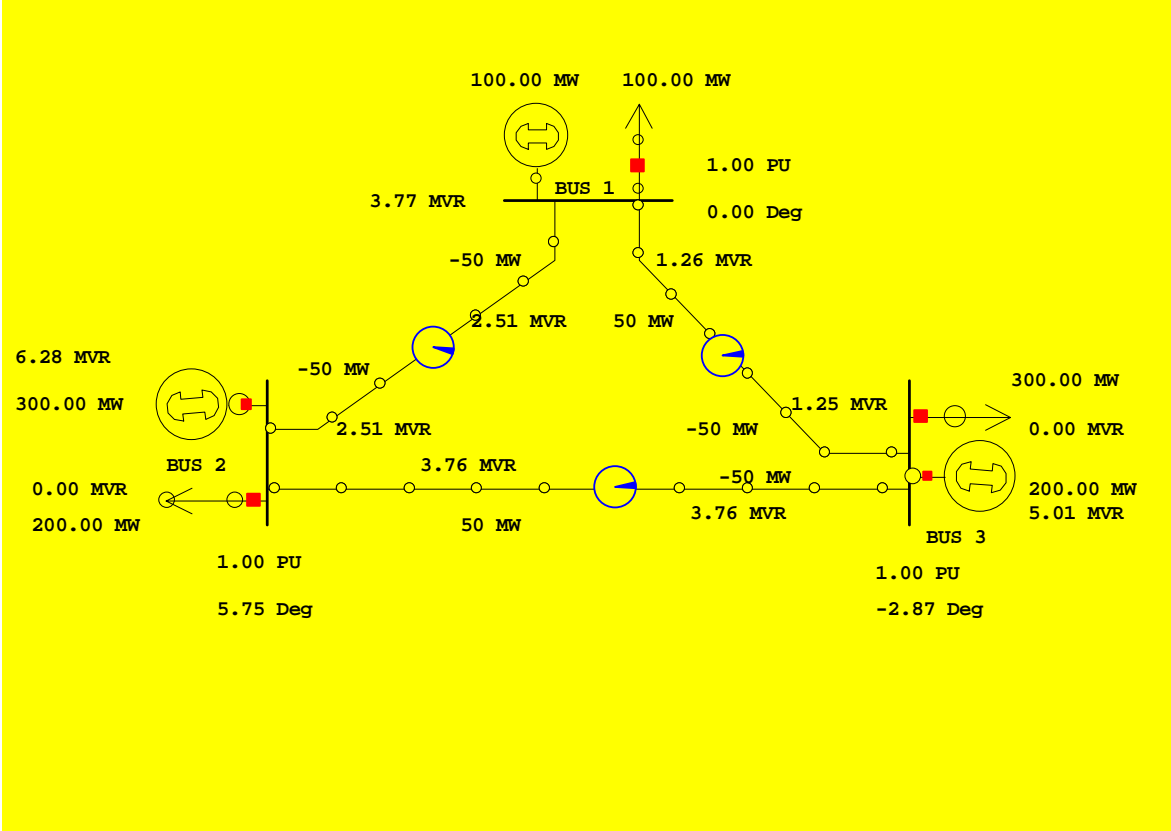

Figure 5.4 Example system with transaction 2

Example System with Transactions 1 and 2

We now consider the scenario where transactions 1 and 2 are on the system simultaneously as shown in Figure 5.5.

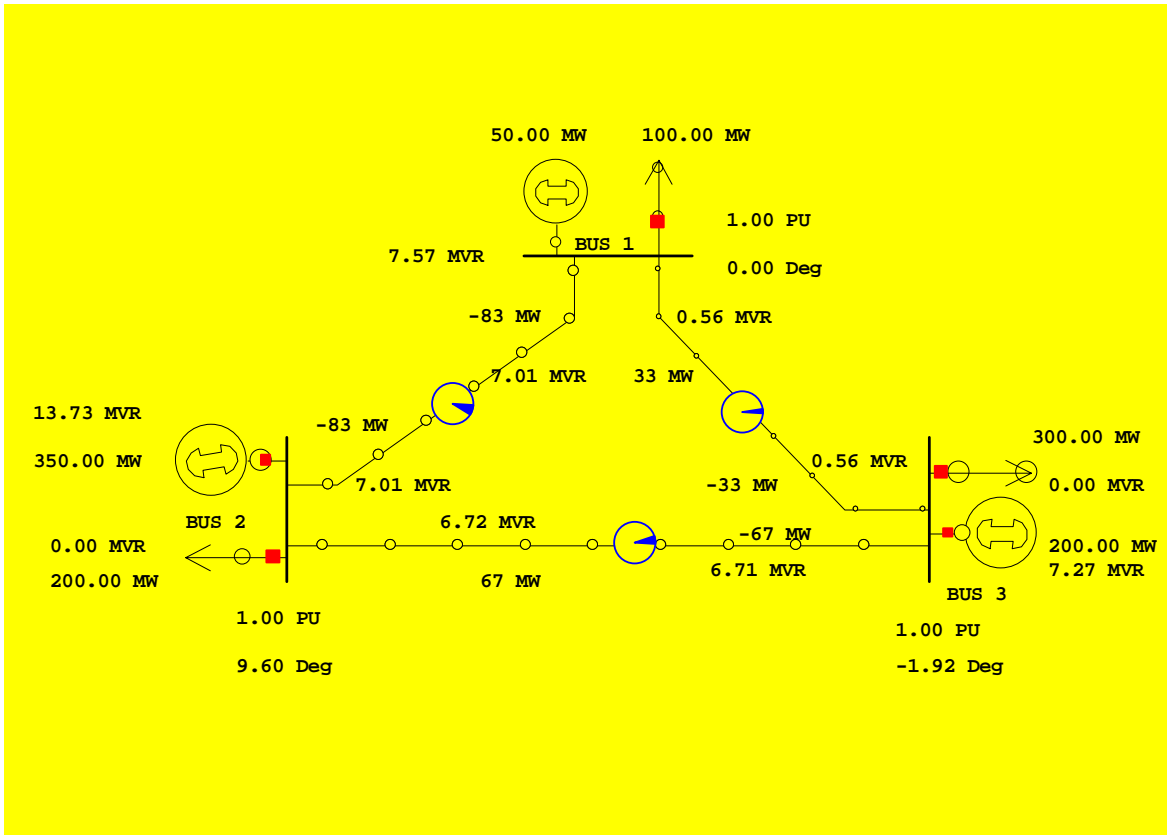

Figure 5.5 Example system with transactions 1 and 2

The power flow shows that in the case that transactions 1 and 2 are implemented at the same time on the system, the reactive power requirement to maintain the bus voltage at 1.0 p.u. at each bus is

$$Q_1^{12} = 7.57 \text{ MVAR}, Q_2^{12} = 13.73 \text{ MVAR}, Q_3^{12} = 7.27 \text{ MVAR}$$

5.1 Simple Pro-Rata Approach

Consider the case when two transactions are on the system at the same time. The total amount of two transactions is

$$t^{(1)} = 50\text{MW}, t^{(2)} = 100\text{MW}, t^{(total)} = t^{(1)} + t^{(2)} = 150\text{MW}$$

We allocate the MVAR output of the generator bus $n = 1, 2, 3$

$$\begin{cases} Q_1^{(1)} = \frac{t^{(1)}}{t^{(total)}} \times Q_1^{12} = \frac{50}{150} \times 7.57 = 2.52\text{MVAR} \\ Q_2^{(1)} = \frac{t^{(1)}}{t^{(total)}} \times Q_2^{12} = \frac{50}{150} \times 13.73 = 4.58\text{MVAR} \\ Q_3^{(1)} = \frac{t^{(1)}}{t^{(total)}} \times Q_3^{12} = \frac{50}{150} \times 7.27 = 2.42\text{MVAR} \end{cases}$$

$$\begin{cases} Q_1^{(2)} = \frac{t^{(2)}}{t^{(total)}} \times Q_1^{12} = \frac{100}{150} \times 7.57 = 5.05\text{MVAR} \\ Q_2^{(2)} = \frac{t^{(2)}}{t^{(total)}} \times Q_2^{12} = \frac{100}{150} \times 13.73 = 9.15\text{MVAR} \\ Q_3^{(2)} = \frac{t^{(2)}}{t^{(total)}} \times Q_3^{12} = \frac{100}{150} \times 7.27 = 4.85\text{MVAR} \end{cases}$$

5.2 An Incremental/Average Approach

First we suppose that transaction one is implemented first and transaction two is undertaken after transaction one is already on the system.

We allocate the MVAR output of the generator bus $n = 1, 2, 3$

$$\begin{cases} Q_1^{(1)} = Q_1^1 - Q_1^0 = 1.26\text{MVAR} \\ Q_2^{(1)} = Q_2^1 - Q_2^0 = 1.53\text{MVAR} \\ Q_3^{(1)} = Q_3^1 - Q_3^0 = 0.56\text{MVAR} \end{cases}$$

$$\begin{cases} Q_1^{(2)} = Q_1^{12} - Q_1^{(1)} = 7.57 - 1.26 = 6.31\text{MVAR} \\ Q_2^{(2)} = Q_2^{12} - Q_2^{(1)} = 13.73 - 1.53 = 12.20\text{MVAR} \\ Q_3^{(2)} = Q_3^{12} - Q_3^{(1)} = 7.27 - 0.56 = 6.71\text{MVAR} \end{cases}$$

Second, we change the order of implementing these two transactions. We assume that transaction one is first exercised and then transaction two is implemented after transaction one has already been on the system.

We allocate the MVAR output of the generator bus $n = 1, 2, 3$

$$\begin{cases} Q_1^{(2)} = Q_1^2 - Q_1^0 = 3.77\text{MVAR} \\ Q_2^{(2)} = Q_2^2 - Q_2^0 = 6.28\text{MVAR} \\ Q_3^{(2)} = Q_3^2 - Q_3^0 = 5.01\text{MVAR} \end{cases}$$

$$\begin{cases} Q_1^{(1)} = Q_1^{12} - Q_1^{(2)} = 7.57 - 3.77 = 3.80\text{MVAR} \\ Q_2^{(1)} = Q_2^{12} - Q_2^{(2)} = 13.73 - 6.28 = 7.45\text{MVAR} \\ Q_3^{(1)} = Q_3^{12} - Q_3^{(2)} = 7.27 - 5.01 = 2.26\text{MVAR} \end{cases}$$

For different order of implementing these two transactions on the system, the results of reactive power allocation are different.

We take the average of the two orders.

$$\begin{cases} Q_{1,ave}^{(1)} = \frac{3.80 + 1.26}{2} = 2.53\text{MVAR} \\ Q_{2,ave}^{(1)} = \frac{7.45 + 1.53}{2} = 4.49\text{MVAR} \\ Q_{3,ave}^{(1)} = \frac{2.26 + 0.56}{2} = 1.41\text{MVAR} \end{cases}$$

$$\begin{cases} Q_{1,ave}^{(2)} = \frac{3.77 + 6.31}{2} = 5.04\text{MVAR} \\ Q_{2,ave}^{(2)} = \frac{6.28 + 12.20}{2} = 9.24\text{MVAR} \\ Q_{3,ave}^{(3)} = \frac{5.01 + 6.71}{2} = 5.86\text{MVAR} \end{cases}$$

5.3 Aumann-Shapley Approach

The previous section has illustrated a method for removing the effect of “ordering” of transactions by averaging over all possible orderings (or two in the example). This method is referred to as “Shapley pricing.” When there are more than two transactions, the number of permutations needed to do the calculation grows as the number of possible combinations of these transactions, but otherwise the method remains the same. In our example, we will assume that

each of the two transactions is divided into a large number of 0.1 MW transactions. This means that transaction 1 consists of 10 steps and transaction 2 consists of 20 steps.

An extension of the Shapley pricing notion is the use of modified Shapley pricing. In modified Shapley pricing each transaction is broken down into a large number of elementary transactions and these transactions are randomized in their order of entry. Again, the amount of work grows combinatorially with the number of transactions, but because the transactions have now been broken down into elementary transactions, the number is much larger.

The Aumann-Shapley theory for pricing reactive power is based on the notion of “fairness” of allocation of a resource. The theory itself is based on game theory. In competitive environments, there are many resources used for the “common good” where no one participant has incentive to provide it without ample compensation for the service. Since the benefits of the service (reactive power, in this case) accrue to all, it is in the common interest that the service be provided. As seen above, a common problem in the compensation for reactive service and many other services is that provision has “nonlinear” effects. In the case of reactive power, provision is highly nonlinear: the last unit of service (the last MVAR in this case) is more valuable than the first. In the previous section, a method of averaging was used to eliminate the “ordering” effect. Aumann-Shapley extends this concept in two ways.

- As in the case of modified Shapley pricing, every “transaction” is itself divided into a large number of smaller transactions.
- As in the case of Shapley pricing, the ordering of these transactions is randomized over all possible permutations of the order in which participants could have provided the service. The average among all these permutations is used as the value to be used for each transaction.

In the limit, as the transaction sizes tends to zero, the calculation of average contribution reduces to the integral of marginal costs when all agents are increased proportionally from zero to their values.

The Aumann-Shapley cost allocation was originally development in the context of games [38]. It was proved in a different context and through other means in [39], that it is the unique cost allocation method which recovers the original costs (revenue reconciliation); and is additive, weakly aggregation invariant and monotonic

Let P_A and P_B be the transaction amounts. Let Δ be the size of each elementary transaction. The transaction of agent A, P_A , consists of N_1 transactions of equal size Δ , and the transaction of agent B, P_B , corresponds to N_2 transactions of equal size Δ , as illustrated below.

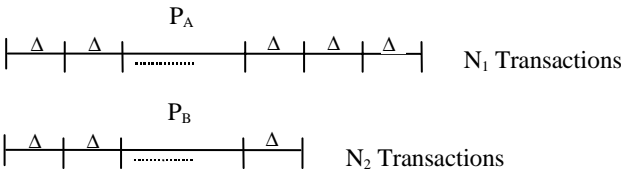

Figure 5.6 Partitioning of transactions

Let $N = N_1 + N_2$ the total number of elementary transactions. The number of possible ways these transactions can be combined is $\binom{N}{N_1}$. Let, for example, $N_1 = 2, N_2 = 3$. In this case the possible transaction orderings are:

AABBB; ABABB; ABBAB; BAABB; BABAB;
BBAAB; ABBBA; BABBA; BBABA; BBBAA

In the case of two agents, each combination corresponds to a path, in a two-dimensional space, from zero to the point whose coordinates are the original transaction values as illustrated in Figure 5.7. Along each path α the mean $\tilde{\pi}_A^\alpha, \tilde{\pi}_B^\alpha$ of the marginal costs are computed. For instance the mean marginal costs for the path of Figure 5.7 are:

$$\tilde{\pi}_A^\alpha = \left(\frac{\partial T}{\partial x}(\Delta, 0)\Delta + \frac{\partial T}{\partial x}(2\Delta, \Delta)\Delta \right) / P_A$$

$$\tilde{\pi}_B^\alpha = \left(\frac{\partial T}{\partial y}(\Delta, \Delta)\Delta \right) / P_B$$

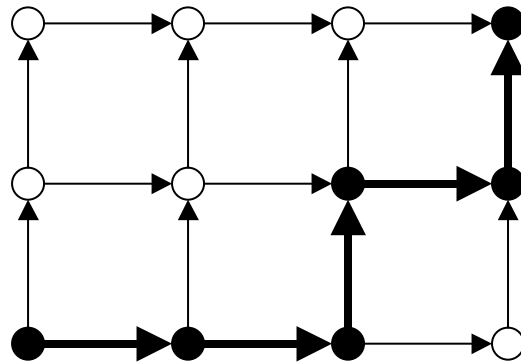

Figure 5.7 Lattice of all paths for all possible transactions combinations
(The path corresponding to BBABA is highlighted.)

The mean of the path mean marginal costs along all paths are:

$$\tilde{\pi}_A = (\sum_{\alpha} \tilde{\pi}_A^\alpha) / N_{\alpha} \tag{5-1}$$

$$\tilde{\pi}_B = (\sum_{\alpha} \tilde{\pi}_B^\alpha) / N_{\alpha} \tag{5-2}$$

where N_α is the number of paths ($N_\alpha = \binom{N}{N_1}$).

The final charges are obtained as the limits when $\Delta \rightarrow 0$.

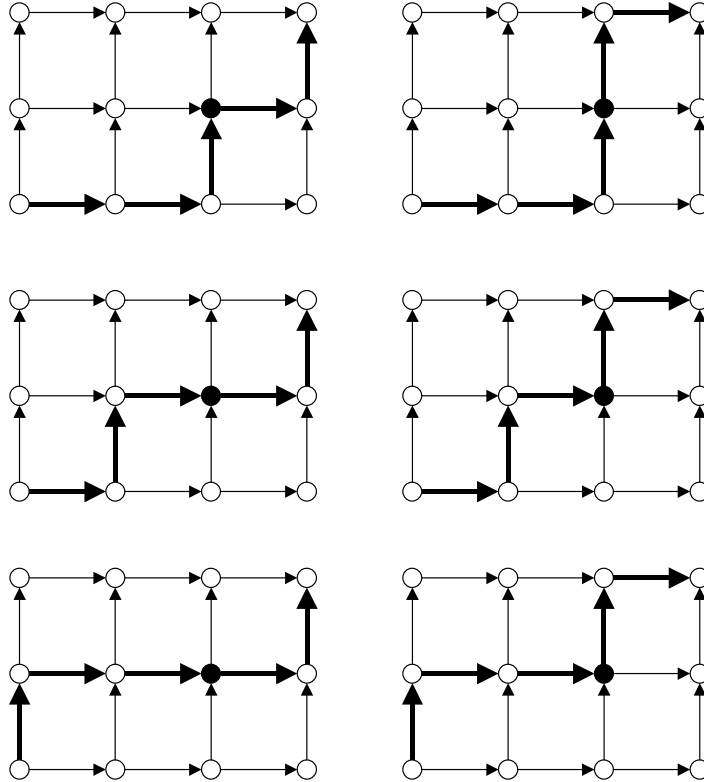

Figure 5.8 The set of paths passing through point (BBA) is illustrated.

The equations above can also be interpreted as the expected values of functions of discrete distributed random variable and when $\Delta \rightarrow 0$, $N, N_1, N_2 \rightarrow \infty$. To take limits, we compute $\tilde{\pi}_A, \tilde{\pi}_B$ as follows:

- Select a point in the two dimensional space (τ_A, τ_B) , $0 \leq \tau_A \leq P_A$, $0 \leq \tau_B \leq P_B$.
- Let $k_1 = \tau_A / \Delta$, $k_2 = \tau_B / \Delta$.
- Consider all possible paths which go through $(k_1\Delta, k_2\Delta)$ and $((k_1+1)\Delta, k_2\Delta)$. The number of such paths is:

$$\binom{k_1 + k_2}{k_1} \binom{N - (k_1 + k_2) - 1}{N_1 - k_1 - 1} = N(k_1, k_2) \frac{N_1 - k_1}{N - (k_1 + k_2)}$$

where

$$N(k_1, k_2) = \binom{k_1 + k_2}{k_1} \binom{N - (k_1 + k_2)}{N_1 - k_1}$$

An example of all such paths for one point is illustrated in Figure 5.8.

$\tilde{\pi}_A$ can be rewritten as

$$\tilde{\pi}_A = \frac{1}{P_A} \sum_{(k_1, k_2)} \frac{N_1 - k_1}{N - (k_1 + k_2)} \frac{N(k_1, k_2)}{N_\alpha} \frac{\partial T}{\partial x}(k_1 \Delta, k_2 \Delta) \Delta$$

or, letting $k = k_1 + k_2$,

$$\tilde{\pi}_A = \frac{1}{P_A} \sum_{k=1}^N \left(\sum_{k_1=1}^k \frac{N_1 - k_1}{N - k} \frac{N(k_1, k - k_1)}{N_\alpha} \frac{\partial T}{\partial x}(k_1 \Delta, (k - k_1) \Delta) \Delta \right)$$

After some analysis and simplification [40] and letting $N \rightarrow \infty$, the Aumann-Shapley per-unit charge is equal to:

$$\tilde{\pi}_A = \int_{\lambda=0}^1 \frac{\partial T}{\partial x}(\lambda P_A, \lambda P_B) d\lambda$$

where λ is an integration parameter, and similarly

$$\tilde{\pi}_B = \int_{\lambda=0}^1 \frac{\partial T}{\partial y}(\lambda P_A, \lambda P_B) d\lambda$$

Observe that:

$$\begin{aligned} P_A \tilde{\pi}_A + P_B \tilde{\pi}_B &= \int_{\lambda=0}^1 \left(P_A \frac{\partial T}{\partial x}(\lambda P_A, \lambda P_B) + P_B \frac{\partial T}{\partial y}(\lambda P_A, \lambda P_B) \right) d\lambda \\ &= \int_{\lambda=0}^1 \frac{d}{d\lambda} T(\lambda P_A, \lambda P_B) d\lambda = T(P_A, P_B) \end{aligned}$$

Thus, in addition to inducing economic efficiency and being fair, the Aumann-Shapley allocation has the desired property of recovering costs and being computable by means of a simple integral.

When applied to the example used so far, Aumann-Shapley pricing leads to the following VAR allocation:

$$\begin{cases} Q_{1,ave}^{(1)} = 2.51\text{MVAR} \\ Q_{2,ave}^{(1)} = 4.67\text{MVAR} \\ Q_{3,ave}^{(1)} = 1.46\text{MVAR} \end{cases}$$

$$\begin{cases} Q_{1,ave}^{(2)} = 5.06\text{MVAR} \\ Q_{2,ave}^{(2)} = 9.27\text{MVAR} \\ Q_{3,ave}^{(3)} = 5.89\text{MVAR} \end{cases}$$

These results were obtained by a sequence of power flows where the transaction levels were increases in 200 increments from a level of zero to their final level. For this very simple example, the difference between Aumann-Shapley and simple Shapley pricing is quite small. For other examples it can be, however, more pronounced.

5.4 A Flow-Based Approach

We first express the reactive power generation from each generator at bus $n=1,2,3$ as

$$Q_n = -B_{nn} V_n^2 + V_n \sum_{j \in H_n} [G_{nj} \sin(\theta_n - \theta_j) - B_{nj} \cos(\theta_n - \theta_j)] V_j$$

In our three-bus example, we assume that

- the system is lossless;
- the voltage is set to 1.0 p.u.;
- the angle difference across each transmission is small, i.e. $\theta_i - \theta_j \approx 0$; and
- the shunt element is neglected.

Under these assumptions,

$$Q_n = \sum_{j \in H_n} \frac{1}{X_{nj}} [1 - \cos(\theta_n - \theta_j)] \approx \frac{1}{2} \sum_{j \in H_n} \frac{1}{X_{nj}} (\theta_n - \theta_j)^2 \approx \frac{1}{2} \sum_{j \in H_n} \frac{1}{X_{nj}} (\theta_n - \theta_j) (\hat{\theta}_n - \hat{\theta}_j)$$

where, through the D.C. power flow, we can decompose $\hat{\theta}$ into components for each transaction as:

$$\begin{aligned}
\begin{bmatrix} \hat{\theta}_2 \\ \hat{\theta}_3 \end{bmatrix} &= \begin{bmatrix} \frac{1}{0.2} + \frac{1}{0.3} & -\frac{1}{0.3} \\ -\frac{1}{0.3} & \frac{1}{0.1} + \frac{1}{0.3} \end{bmatrix}^{-1} \begin{bmatrix} t^{(1)} = 0.5 \\ 0 \end{bmatrix} + \begin{bmatrix} \frac{1}{0.2} + \frac{1}{0.3} & -\frac{1}{0.3} \\ -\frac{1}{0.3} & \frac{1}{0.1} + \frac{1}{0.3} \end{bmatrix}^{-1} \begin{bmatrix} t^{(2)} = 1 \\ -t^{(2)} = -1 \end{bmatrix} \\
&= \begin{bmatrix} 0.1333 & 0.0333 \\ 0.0333 & 0.0833 \end{bmatrix} \begin{bmatrix} t^{(1)} = 0.5 \\ 0 \end{bmatrix} + \begin{bmatrix} 0.1333 & 0.0333 \\ 0.0333 & 0.0833 \end{bmatrix} \begin{bmatrix} t^{(2)} = 1 \\ -t^{(2)} = -1 \end{bmatrix} = \begin{bmatrix} 0.1333*t^{(1)} + 0.1*t^{(2)} \\ 0.0333*t^{(1)} - 0.05*t^{(2)} \end{bmatrix} \\
&= \begin{bmatrix} 0.0667 \\ -0.0167 \end{bmatrix} + \begin{bmatrix} 0.1 \\ -0.05 \end{bmatrix} = \begin{bmatrix} 9.57^0 \\ -1.91^0 \end{bmatrix}
\end{aligned}$$

then, from generator at bus 1

$$Q_1^{(1)} = \frac{1}{2*0.2} (0 - 9.6) / 180 * 3.14 * (0 - 0.0667) + \frac{1}{2*0.1} (0 + 1.92) / 180 * 3.14 * (0 - 0.0167) = 0.5 * (0.0558 - 0.00559) = 0.025$$

$$Q_1^{(2)} = \frac{1}{2*0.2} (0 - 9.6) / 180 * 3.14 * (0 - 0.1) + \frac{1}{2*0.1} (0 + 1.92) / 180 * 3.14 * (0 + 0.05) = 0.5(0.0837 + 0.0167) = 0.05$$

and, the total output for transactions 1 and 2 is

$$Q_1^{(1)} + Q_1^{(2)} = 0.075 \text{ p.u.}$$

From generator at bus 2

$$\begin{aligned}
Q_2^{(1)} &= \frac{1}{2*0.2} (9.6 - 0) / 180 * 3.14 * (0.0667 - 0) + \frac{1}{2*0.3} (9.6 + 1.92) / 180 * 3.14 * (0.0667 - 0.0167) \\
&= 0.0279 + 0.0167 = 0.044
\end{aligned}$$

$$Q_2^{(2)} = \frac{1}{2*0.2} (9.6 - 0) / 180 * 3.14 * (0.1 - 0) + \frac{1}{2*0.3} (9.6 + 1.92) / 180 * 3.14 * (0.1 + 0.05) = 0.0419 + 0.05 = 0.0919$$

and the total output for transactions 1 and 2 is

$$Q_2^{(1)} + Q_2^{(2)} = 0.1359 \text{ p.u.}$$

From generator at bus 3

$$\begin{aligned}
Q_3^{(1)} &= \frac{1}{2*0.2} (-1.92 - 0) / 180 * 3.14 * (0.0167 - 0) + \frac{1}{2*0.3} (-1.92 - 9.6) / 180 * 3.14 * (0.0167 - 0.0667) \\
&= -0.0014 + 0.0167 = 0.0153
\end{aligned}$$

$$\begin{aligned}
Q_3^{(2)} &= \frac{1}{2*0.2} (-1.92 - 0) / 180 * 3.14 * (-0.05 - 0.1) + \frac{1}{2*0.3} (-1.92 - 9.6) / 180 * 3.14 * (-0.05 - 0.1) \\
&= 0.013 + 0.05 = 0.063
\end{aligned}$$

$$\begin{aligned}
Q_3^{(2)} &= \frac{1}{2*0.2} (-1.92 - 0) / 180 * 3.14 * (-0.05 - 0.1) + \frac{1}{2*0.3} (-1.92 - 9.6) / 180 * 3.14 * (-0.05 - 0.1) \\
&= 0.013 + 0.05 = 0.063
\end{aligned}$$

and the total output for transactions 1 and 2 is

$$Q_3^{(1)} + Q_3^{(2)} = 0.0783 \text{ p.u.}$$

Therefore,

$$\begin{cases} Q_1^{(1)} = 2.5\text{MVAR} \\ Q_2^{(1)} = 4.4\text{MVAR} \\ Q_3^{(1)} = 1.53\text{MVAR} \end{cases}$$

$$\begin{cases} Q_1^{(2)} = 5\text{MVAR} \\ Q_2^{(2)} = 9.19\text{MVAR} \\ Q_3^{(2)} = 6.3\text{MVAR} \end{cases}$$

This algorithm is documented in detail with additional illustrations in [58].

6

RELATING VALUE AND COST OF VARs

6.1 Unit Operation with System Considerations

A supplier of energy (that is, a generator) has a positive marginal profit when the price of energy sold exceeds the marginal cost of production. For a total profit to be achieved, it is necessary that the total revenues over the entire operating period (or business cycle) exceed the total costs. Total costs include not only operating costs but also any startup and shutdown costs. In this analysis, we consider that revenues derive from three sources: the sale of energy (at the spot or contract price), the sale of reactive power, and the sale of reactive reserves. For simplicity, we do not consider the sale of active power reserves analysis. We focus mainly on daily and weekly business cycles.

We consider first a situation with no startup and shutdown costs, where the price of energy λ exceeds the marginal cost of production c . We further assume there is no payment for reactive power supplies. This situation is depicted in Figure 6.1(a). Under these conditions, it is advantageous for the generating unit to produce energy at the maximum possible net output level, since this maximizes the generator's profit contribution (or, as shown in the figure, surplus). There is no incentive to deliver any particular amount of reactive power. The desired amount of reactive power to be delivered by the unit is whatever the generator finds most profitable for the production of a maximum possible amount of active power. The typical dependency of net P capability on Q output is illustrated in Figure 6.1(b). The net output for a generating unit is the output produced by the unit at the operating point, excluding any losses for which the generator does not get compensated (such as rotor and stator losses).

The following conflicting factors play into the desired production of reactive power.

- Delivering a larger amount of reactive power will tend to increase voltages and reduce currents, thus leading to lower stator currents for a designated amount of active power.
- Delivering a larger amount of reactive power will reduce the power factor, leading to a larger current than necessary and thus leading also to greater stator losses.
- Delivering a larger amount of reactive power requires greater field currents, thus resulting in larger rotor losses.
- Delivering a larger amount of reactive power may reduce the maximum permissible amount of power that the machine can produce.

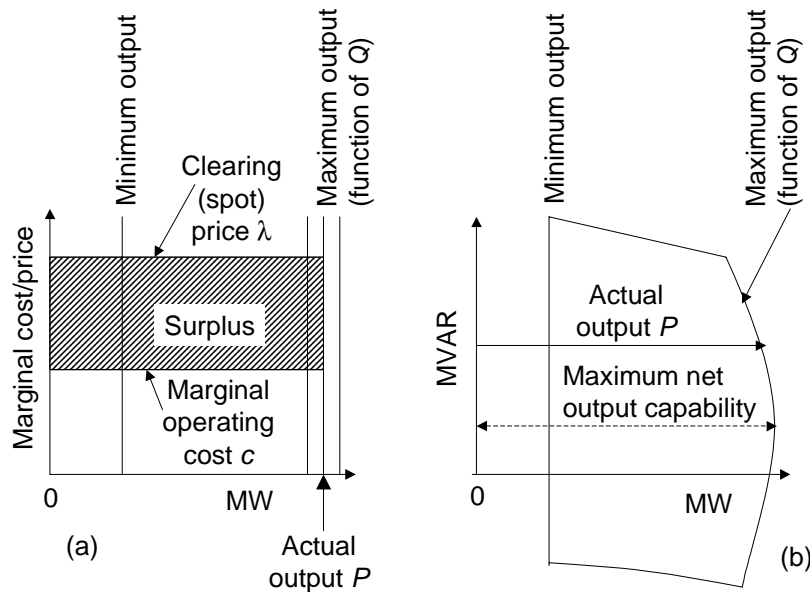

Figure 6.1 When there is no payment for reactive power deliveries, it is advantageous for the generator to supply the output that maximizes its own revenues. (a) The area indicates the net contribution to profit (or surplus) to the supplier. (b) Relationship between P and Q output.

We next consider the situation of a unit that is out of service. We assume that the energy price exceeds the marginal cost of production. However, we also assume that there is a nontrivial startup cost. For simplicity of exposition we ignore shutdown costs since these costs can be accounted for in a similar manner. We will assume that there is no payment for reactive power production. This situation is almost the same as the one just described, except that the unit will not be started unless the expectation of recovery of startup costs is present.

Let S be the startup cost of the unit. We assume there are T time periods of interest, and that the operating expense c per unit of generation is the same for all periods. We let $\lambda(t)$ be the price received for production during period t . The contribution to profit or surplus during any period is equal to the amount of energy produced during the period times the difference between price and cost. We assume the periods to be of length unity each. The energy produced during period t is thus proportional to the power output $P(t)$. The surplus (or loss) for energy production for a given unit is $P(t)*(\lambda(t)-c(t))$. For all T periods, the net surplus or loss is either $\Sigma[P(t)*(\lambda(t)-c(t))]-S$ or zero, whichever is largest (since the unit will not be started unless a net profit can be anticipated). If the unit is not started as a result of insufficient compensation, let ΔS denote the total shortfall. That is, let $\Delta S = S - \Sigma[P(t)*(\lambda(t)-c(t))]$. This shortfall value will always be positive (or zero).

The situation of changing prices over time and the relationships between profits, prices and costs is illustrated in Figure 6.2. Assume the generating unit is permitted to vary its output from one period to the next. The unit is not allowed to shut down once it has been started. Under these conditions, it is advantageous for the unit to produce maximum power during those periods where a profit can be realized. Likewise, it is advantageous to produce minimum output during those periods where a loss is incurred, leaving the unit on for the next opportunity for profits but minimizing the losses of the period. Thus, the net surplus for the unit will be as above, except that if the unit is on then $P(t)=P_{\max}$ if $\lambda(t)>c$, and $P(t)=P_{\min}$ if $\lambda(t)<c$.

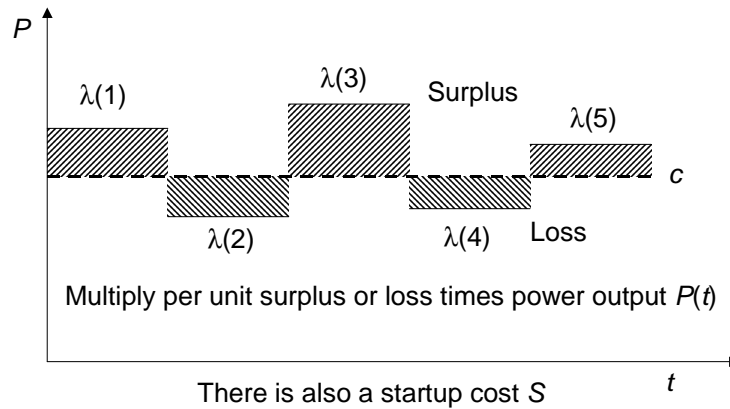

Figure 6.2 Variation of surplus or loss as a function of energy price variations

The next situation we considered is the case where there is an explicit value to the reactive power. The value of the reactive power to the system can take one of two forms.

- Reactive power injection or extraction can reduce total system losses. The value of the reactive power for this purpose is the value of the Lagrange multiplier equation associated with the reactive power injection at the generator location. Generally this value is comparatively small, ranging from a negative value of 20% or above to a positive value of above 20%, but more typically being somewhere between 2% and 4%.
- There may be a binding system constraint. The binding system constraint may be the voltage at some bus which may not go below (or above) some designated values. The binding constraint can also be the flow on a line or transformer. Adjustments of reactive power injections can affect the current in the line or transformer. Thus, the value of reactive power is the value of the injection in relieving the constraint (the Lagrange multiplier of the constraint).

When reactive power has value, we assume that a payment at the value of the reactive power is justified and will take place. In other words, the supplier of generation is offered a payment for reactive power provision that equals the benefit of the reactive power to the system. Thus, the net proceeds to a generator now consist of the sum of the revenues associated with the energy supply and the reactive supply reserve sales.

We now investigate how these assumptions alter the economics of unit operation. We assume that the value of an increment of reactive power injection into the system is μ . (In the more general case, we will assume that μ can vary as a function of t .) For a single time period and no startup costs, Figure 6.3 illustrates the nature of the benefits. In brief, as a result of additional reactive injection, the system can reduce its losses (thus deriving a direct energy benefit), and it may also be able to relieve a binding constraint (also leading to more economic overall operation).

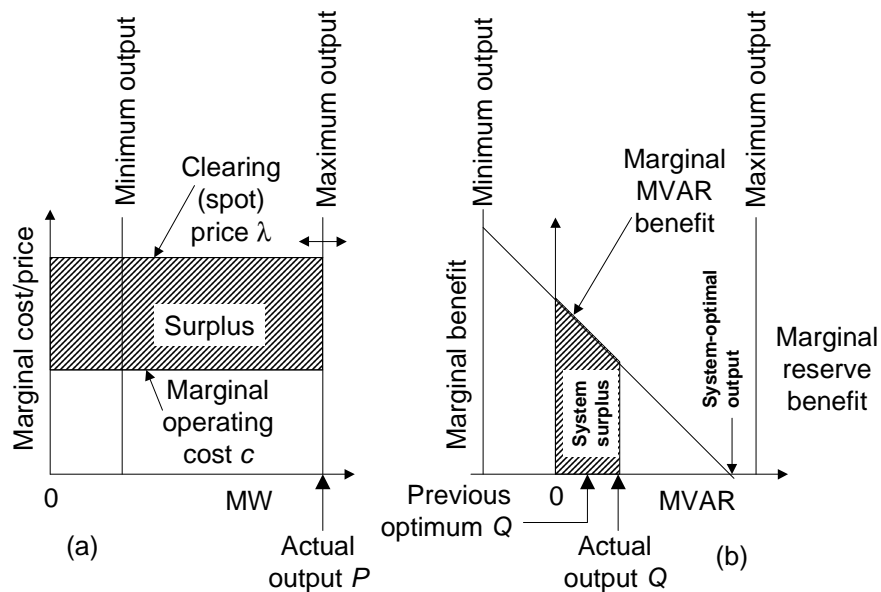

Figure 6.3 Benefit to the supplier of producing energy (a), and benefit to the system of having supplier produce reactive power (b). The benefit is expected to be a declining benefit, although the slope could be in some cases reversed. In the more general case, it will be a nonlinear function of Q . The benefit to the system derives from lower losses and from the improvement of constraints.

We observe from Figure 6.3 that the benefit declines as Q increases (in this case). This declining benefit from larger Q is an important feature of reactive power, otherwise, the incentives for providing reactive power will not be correct. Thus, the system operator can provide an incentive for the supply of reactive power to a given location based on the marginal system benefit.

Various incentives structures can be considered by the system operator.

- A payment on a “per MVAR” basis. Here the system operator decides that there is a marginal benefit to the system and offers to pay for each MVAR. This approach is not likely to work well. Assume that the opportunity cost to a supplier of offering a MVAR of power is negligibly small. Then the supplier will elect to produce the maximum possible amount of VARs. Worse yet, multiple suppliers at that location will offer to provide their maximum.

The operator will quickly be in a position of having excess VARs and having to perhaps pay to cancel them.

- Bid a continuously declining formula for VAR provision. In effect, the operator would offer payment that is, in effect, based on a quadratic formula. The difficulty with this approach is that competing suppliers for VARs that have identical opportunity costs will have a hard time competing, since their costs are virtually identical. The market for VARs will be unstable.
- Offer to purchase a specific amount of VARs (or range of VARs) at a given price from a single or from multiple sources. This case (which is the preferred situation) is illustrated in Figure 6.4. Under these conditions what used to be a system surplus becomes a surplus for the generator (assuming that the impact on active power delivery for the supplier of energy is small). This will make it possible for a generator to, in effect, lower its effective marginal cost for active power.

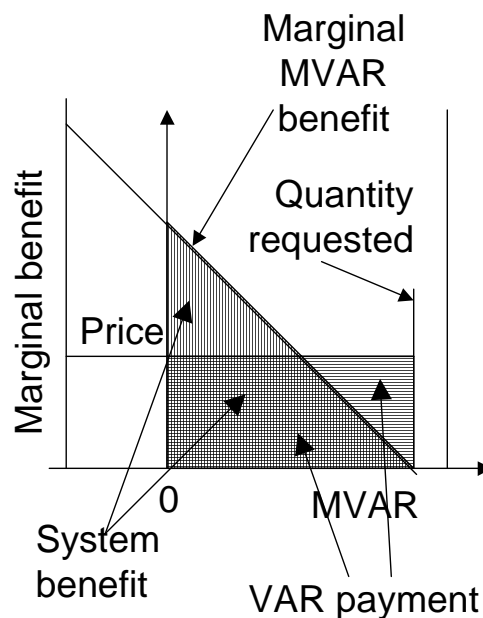

Figure 6.4 Benefits and payments for reactive power at a given location. The system operator indicates both a price he/she is willing to pay as well as an amount needed. Note: if the amount of MVARs available at a given location is insufficient, a partially filled request will take place, along with some surplus loss. A price increase will yield no additional MVARs.

Actually, in the situation depicted above, the marginal benefit to the system of delivering the last MVAR is not “cost effective” in the sense that the same price paid for the last MVAR exceeds the benefit to the system. Thus, a “system-only” viewpoint would suggest that it is optimal to either lower the price or restrict the quantity of VARs purchased to values below the combined optimal level. Neither is optimal if the “system plus supplier” combined welfare is considered. A narrow viewpoint results in an undersupply of reactive power which leads to other difficulties.

The fact that the VAR payments to a supplier result in additional surplus results in the ability of the supplier to realize a profit even in the presence of relatively low energy prices. The situation

is illustrated in Figure 6.5. Here the price of energy is not high enough to warrant production. However, because of the high value of reactive power to the system (which leads to an explicit payment for reactive power supply), the net result is still profitable for the generator.

A similar but slightly more complex analysis can be applied to determine the value of reactive power for the case where multi-period operation with nonzero startup costs needs to be considered.

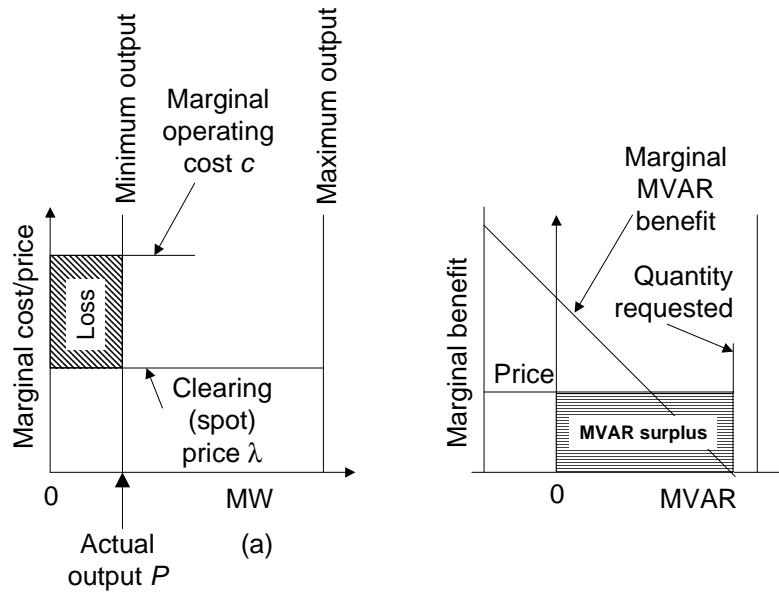
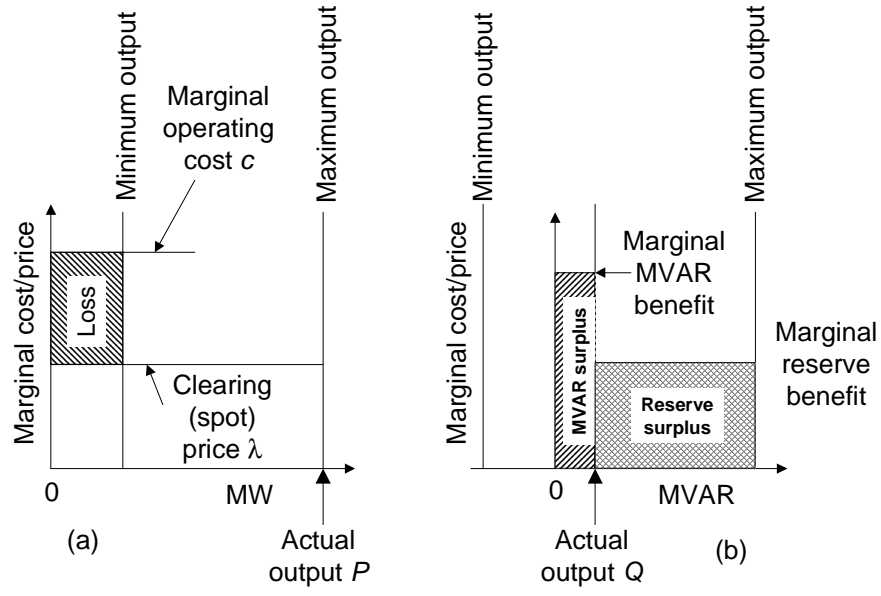

Figure 6.5 The payment for reactive supplies results in the profitable operation of the generator even when prices are not sufficiently high to warrant generation under normal circumstances.

In the analysis above we have considered that only the explicit and delivered component of the reactive power has value. In truth, there is often a quite significant value to reactive reserves (often in both directions). Figure 6.6 illustrates the benefits to the system of having reactive reserves. When reactive reserves are quantified (and if an explicit payment for reactive reserves is made) then the economics of energy production once again improve. The outages in the West during 1998 were in large part attributed to insufficient reactive reserves at some locations where available (hydro) generators that could have been functioning as synchronous condenser were available. Operating protocols have not been changed to permit operation of these generators in this mode when circumstances require it.



Startup cost and shutdown costs are also given

Figure 6.6 Incorporating the value of reactive reserves.

6.2 Reactive Support Service and Lost Opportunity Costs

Characteristics of Reactive Support

We start our discussions with the motivation for reactive support, using an example with four scenarios.

Example 6.1:

Consider the simple two-bus system of Figure 6.7.



Figure 6.7 The two-bus system

The line connecting the two busses is lossless with an impedance of $j0.2$ p.u. and a charging capacitor admittance of $-j0.005$ p.u. at each end of the line. The voltage at each bus must be held within the range $[0.95, 1.05]$. The excitation control of the generator can set the voltage at bus 1 at a specified value. The voltage set-point of the generator is denoted by V_1^s . The reactive power required from the generator is denoted by q_1^g .

Case 1.a:

This case starts without a transaction on the system and no real power flowing on the line. While the generator absorbs reactive power injected by the line charging capacitor at bus 1, the reactive power injected at bus 2 makes the voltage V_2 at bus 2 slightly higher than V_1^s . This is representative of the light-load situation under which the generator needs to withdraw reactive power to prevent unsatisfactory high voltages.

Case 1.b:

Next, we consider a 100 MW transaction from the generator at bus 1 to the load at bus 2. Although there is no reactive load at bus 2, the transaction gives rise to a current, which, in turn, results in reactive power losses in the line that must be provided. Since the only reactive source is the generator, the required reactive support is obtained therefrom. V_2 drops to 0.98 p.u. due to the transaction. To maintain V_2 within specified limits, the load at bus 2 needs to acquire reactive support in addition to the purchase of real power. Otherwise, V_2 would become

unacceptably low. Figure 6.8 shows the variation of V_2 as a function of the transaction amount for different values of V_1^s . Note that for a fixed transaction amount, raising V_1^s increases V_2 .

A, B, and C are V_2 when V_1^s is 1.05, 1.0 and 0.97 p.u., respectively

D, E, and F are q_1^g when V_1^s is 1.05, 1.0 and 0.97 p.u., respectively

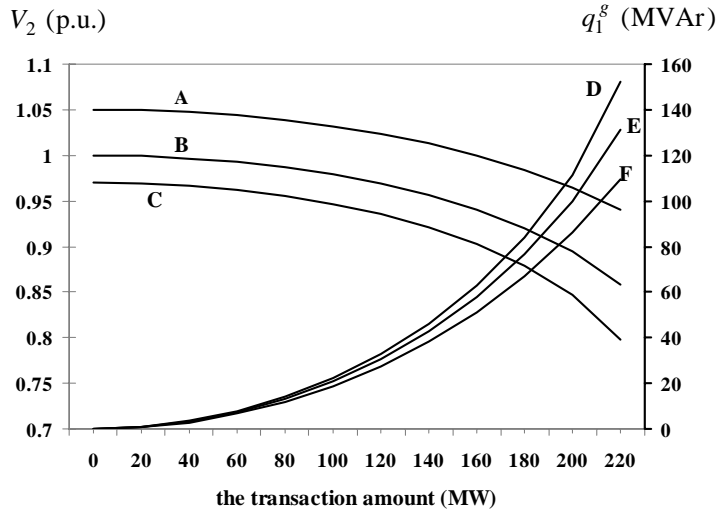

Figure 6.8 The voltage at bus 2 and the reactive support by the generator

For instance, when the transaction amount is 140 MW and V_1^s is 0.97 p.u., V_2 is 0.92 p.u. To raise V_2 to 0.95 p.u., the generator needs to increase V_1^s to 1.0 p.u. The generator can control to some extent V_2 by adjusting V_1^s . Meanwhile, the generator must also provide the reactive support to ensure the voltage profile requirement is satisfied. For example, raising V_1^s from 0.97 p.u. to 1.0 p.u. changes the reactive power output of the generator changes from 46 to 43 MVAR. In this example, when V_1^s is raised to improve V_2 , the reactive support of the generator decreases. Figure 6.8 also shows that for a fixed V_1^s the amount of the reactive support required from the generator increases as the transaction amount increases.

Case 1.c:

Now we double the value of the reactive line impedance. The 100 MW transaction would drag V_2 to 0.90 p.u. and q_1^g increases by 150%. Hence, the larger the line reactance, the lower the load voltage becomes and the larger the amount of reactive support required from the generator.

Case 1.d:

In this case, we consider the case of non-unity power factor. For example, besides 100 MW of real power, we let the load at bus 2 also consume 50 MVAR of reactive power (the power factor of the load is 0.9). V_2 is depressed to a very low value of 0.86 p.u., and the generator must increase its reactive power output to cover the reactive losses on the line and serve the reactive

load as well. Thus, the reactive load adds an extra burden on the system for reactive support. The retail customers at bus 2 may reduce this additional burden on the system by installing shunt capacitors to correct the power factor.

We summarize the nature and characteristics of reactive support illustrated by this example.

1. Due to the reactive nature of transmission systems, reactive support is an inherent physical system requirement for maintaining acceptable voltage profiles.
2. Even without reactive loads on the system, power transactions result in the critical needs of reactive support.
3. A generator controls voltages by adjusting its voltage set-point. However, the actual system voltage profile and the corresponding reactive power needed to support the voltage profile also depends on other factors such as the generation or load pattern and the line parameters

Example 6.2:

Case 2.a:

There are no transaction on the system and the different values of the voltage set-points of the generators at buses 1 and 2 ($V_1^s = 1.0$ p.u. and $V_2^s = 1.03$ p.u.) give rise to currents flowing on the lines that result in reactive power losses. There is no real power flowing on the lines. Since, in general, reactive power flows from the location with a high voltage to the location with a lower voltage, the generator at bus 2 produces reactive power and the generator at bus 1 absorbs reactive power. We denote by q_1^g and q_2^g the reactive power output of generators at buses 1 and 2, respectively. Thus, even when no transaction is present on the network, the reactive nature of the transmission network results in the need for reactive support to establish the specified voltage profile.

Case 2.b:

Next, we consider Case 2 where a 400 MW transaction between the generator at bus 2 and the load at bus 4 is undertaken. We assume that the voltage v_3 and v_4 at buses 3 and 4 must be kept between 0.95 p.u. and 1.05 p.u. Due to the transaction, v_4 drops to 0.94 p.u., which is an unacceptably low and violates the voltage constraint. Meanwhile, q_1^g and q_2^g increase. Reactive support must be provided at bus 4 to raise v_4 . From an economic viewpoint, it may be natural and expected that reactive power should be provided at buses 2 and 4 to support the transaction since they are directly involved in the transaction. It is not obvious that the generator at bus 1, which is not part of the transaction, is also required to provide reactive support. This is because though the transaction is from bus 2 to bus 4, only a part of the transacted 400 MW flows on the line connecting buses 2 and 4. The loop flow created by the transaction requires the generator at bus 1 to provide reactive support.

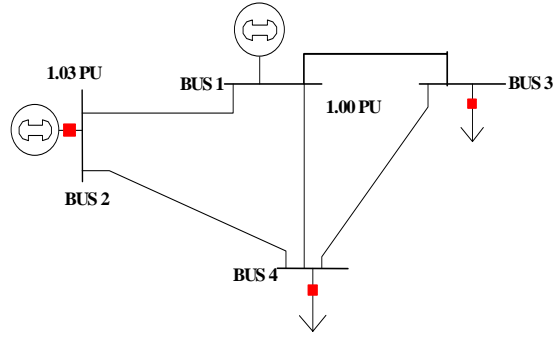

Figure 6.9 The four-bus system

Case 2.c:

The reactive support provided by the generator at bus 1 is critical for the transaction. Even after sufficient reactive support is provided at bus 4 to keep V_4 at 1.0 p.u., if no reactive support is available at bus 1, then V_3 would reach its limit of 0.95 p.u. when the transaction is increased to 960 MW. In other words, without reactive support at bus 1 and under the current values of V_1^s and V_2^s , the voltage constraint at bus 3, which is not contractually involved in the transaction either, allows at most 960 MW to be transferred from bus 2 to bus 4. Meanwhile, this indicates that since the reactive power flows from the location with a higher voltage to the location with a lower voltage, the generator at bus 1 may lower V_1^s to avoid its share of reactive support and “lean” on the unit at bus 2 for the required reactive support. q_2^g increases almost 5 times with respect to **Case 2.b** in this case because the generator at bus 2 becomes the only reactive power source for the whole system, and its location is more electrically distant from the load at bus 3 than the generator at bus 1. This results in higher reactive power losses. We will discuss the local nature of reactive support in the next example.

Case 2.d:

Now we assume that another 150 MW transaction from the generator at bus 1 to the load at bus 3 comes on line. Now, not only is V_3 decreased, but V_4 is also dragged down to an unacceptable level. The generator at bus 1 has to raise V_1^s to hold V_3 and V_4 within the specified limits.

The comparison of **Cases 2.a** and **2.d** indicate that q_1^g and q_2^g increase. While the increased reactive power outputs may be considered the reactive power service provided to support the two transactions, it is very difficult (and to some extent arbitrary) to determine how many MVAR each generator provides for which transaction.

The characteristics illustrated by this example are summarized as follows.

- (1) Reactive support must be provided on a system-wide basis in a coordinated manner. A generator, which is not involved contractually in a transaction, is required by the system to provide the reactive power service to support for the transaction.
- (2) A generator may avoid its share of the reactive support and lean on other generators by lower its voltage set-point and withholding its reactive power output.

- (3) Even in absence of transactions on the system, the reactive nature of the transmission system gives rise to the need of reactive support to establish the specified voltage profile. For a network with multiple transactions, it is difficult and arbitrary to allocate the reactive power service provided by a generator to individual transactions.

Table 6.1 The simulation results on the four-bus system

Cases	V_1^s (p.u.)	Transaction amount (MW)	The line impedance (p.u.)	The power factor of the load at bus 2	V_3 (p.u.)	q_1^g (MVAR)
1.a	1.0	-	0.02	1	1.001	-1
1.b	1.0	100	0.02	1	0.98	20
	0.97	140	0.02	1	0.92	46
	1.0	140	0.02	1	0.95	43
1.c	1.0	100	0.04	1	0.90	49
1.d	1.0	100	0.02	0.9	0.86	83

Due to the losses of reactive power on the transmission network, it is not desirable (or sometimes infeasible) to provide reactive power support from a remote source. We use a seven-bus system in Figure 6.10 to illustrate the local nature of the reactive power support.

Example 6.3 (Local nature of reactive support):

In this example, we assume that all bus voltages must be kept within [0.95, 1.07]. As the power

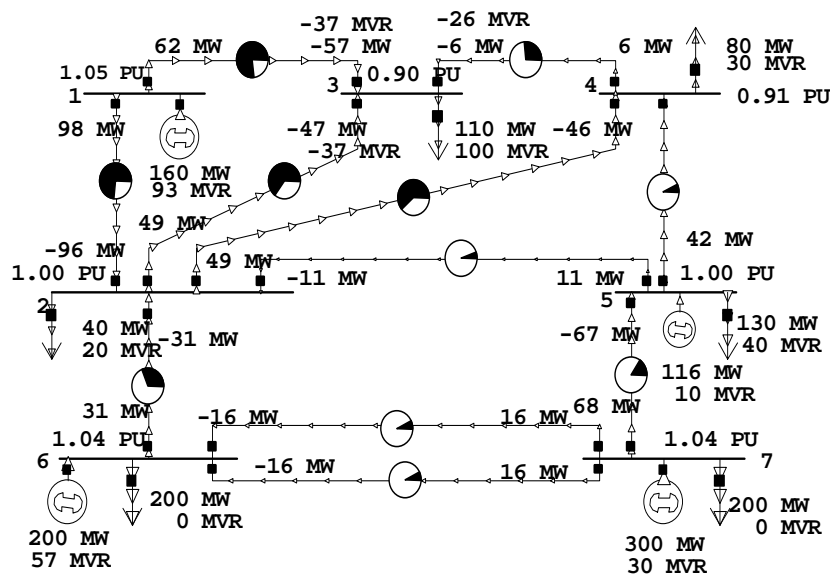

Figure 6.10 The seven-bus system with voltage violation at bus 3

flow in Figure 6.10 indicates, the voltage V_3 at bus 3 is 0.90 p.u. that violates the voltage constraint. Reactive support needs to be provided to raise V_3 to 0.95 p.u. We may inject reactive power directly at bus 3, or use reactive support provided by one of the generators at buses 1, 6 and 7, which are increasingly distant from bus 3 electrically. Bus 5 is the swing bus.

Table 6.2. Reactive support at various locations needed to raise the voltage at bus 3 from 0.9 p.u. to 0.95 p.u.

Location	Amount of reactive support injected q_{inj} (MVAR)	Amount of injected reactive support that reaches bus 3 q_{rec} (MVAR)	$\frac{q_{inj} - q_{rec}}{q_{inj}}$ (%)
Bus 3	39	39	0
Bus 1	71	12	83
Bus 6	126	5	96
Bus 7	370	5	99

The comparison results in Table 6.2 show that as reactive support is provided from a more distant (electrically) node, the reactive power losses increase so much as to soak up virtually all the reactive support. In fact, supplying reactive support at some location (e.g. bus 7) for improving the voltage at bus 3 is infeasible. The generator at bus 7 has to increase its voltage setting value to 1.19 p.u., which is unacceptably high, and inject 370 MVAR to increase V_3 to 0.95 p.u. The MVA line flow from bus 7 to bus 5 is increased from 82 MVA to 359 MVA, which may violate the MVA limit of the line. The results indicate that reactive support should be provided at the place where it is most needed. In our case, it is bus 3. The direct consequence of the characteristics is that if generators at these locations compete with each other to provide the reactive support to bus 3, the generator at bus 3 would be in an advantageous position. In fact, if there is only one generator at bus 3, it could be the monopolist for providing the service since it may be the only feasible choice in specific situations. Hence, this example is illustrative of the general principle: Due to the high losses on the system, the local provision of reactive support is the best solution to improve voltages.

Reactive support capability of the generator

As discussed in Section 4.1, there is a physical constraint in providing reactive support service. The operation of a generator is subject to a generator PQ capability constraint. A typical capability constraint curve was given in Figure 4.5, and is repeated in Figure 6.11.

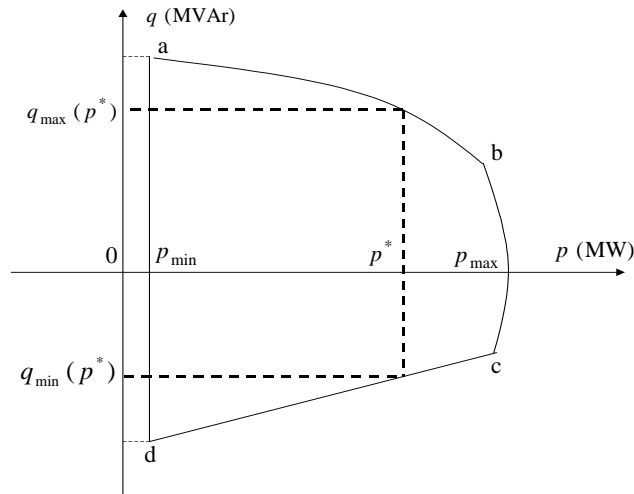

Figure 6.11 The generation capability constraint (the loading diagram)

As noted in Section 4.1, different physical constraints determine the shape of the capability constraint curve. The real and reactive power production of the generator is constrained by the field current limit (segment a-b), the armature current limit (segment b-c) and the under-excitation limit (segment c-d). If the generator's present real power output is p^* , then its reactive power output must be within $q_{\min}(p^*)$ and $q_{\max}(p^*)$. Thus, the generator's reactive support capability varies with its real power production level. To understand the effect of the generation capability constraint on the system operation, we will revisit *Case 1.b* in *Example 6.1* in Figure 6.7.

Example 6.4 (Case 1.b revisited):

Assume that the transaction between buses 1 and 2 is 200 MW. Figure 6.7 indicates that the voltage set-point V_1^s needs to be 1.05 p.u. to maintain the voltage V_2 at bus 2 at 0.96 p.u. Consequently, as indicated by point a in Figure 6.12, the generator needs to produce 86 MVAR to support this voltage profile. However, the amount of the reactive support required from the generator is larger than its reactive power production capability as determined by its present real power generation level. At 200 MW, the generator can only operate at b, at which the generator reaches its maximum reactive power production limit $q_{1,\max}$ of 40 MVAR. V_1^s cannot be held at its specified value, and the bus voltages will be outside the allowable ranges.

As a result of the generation capability constraint, the transaction has to be curtailed. On the one hand, as the transaction amount decreases, the reactive support requirement upon the generator decreases; on the other hand, the reactive power output capability of the generator increase as its real power production decreases. At the intersection point c, the unit is just able to provide the

required reactive support 63 MVAR to hold V_1^s at 1.05 p.u. The transaction must be reduced to 175 MW so that V_2 will be at the satisfactory level of 0.98 p.u.

Thus, this example shows that:

- (1) The generation capability constraint imposes an additional physical limit in providing reactive support.
- (2) Since a generator's reactive support capability varies with its real power output, its real power output may have to be decreased to meet the need of reactive support as determined by the system operating condition

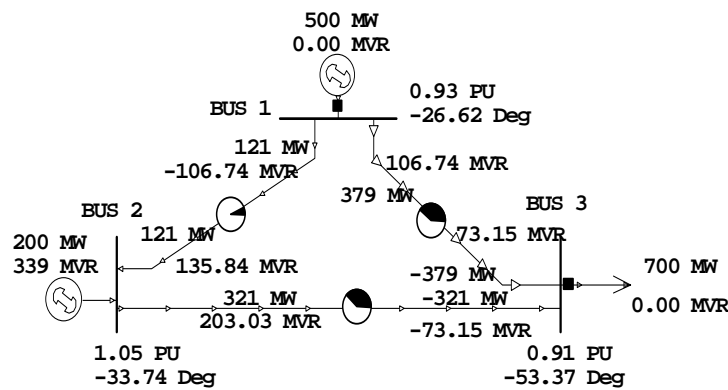

Figure 6.13 The economic dispatch without voltage consideration

Cost Structure for Reactive Support

There are two types of explicit costs associated with the provision of reactive support: reactive power capacity and operation costs. A considerable amount of work has been done investigating how to allocate the capacity and operating costs of a generator to its reactive support provision. A fundamental difference between real power and reactive power is that the operation cost of reactive power is negligibly small compared to its real power counterpart. In effect, if the generation capability constraint is not active for a given operating condition, reactive power provided by a generator may be considered as a by-product of the real power production process with negligible additional costs to the generator. However, once the generation capability constraint becomes active, the reactive support to meet voltage requirements may force the reduction of real power output. This deviation from a preferred operating point may result in an implicit cost to the generator since the generator may have to compromise its own objective to meet the system requirement. This cost should be included as an additional component in the cost structure of reactive support service. We use the system shown in Figure 6.13 to illustrate

the effect of the reactive support requirement on the real power operation of generators and consequently this implicit cost incurred by generators in providing the reactive support.

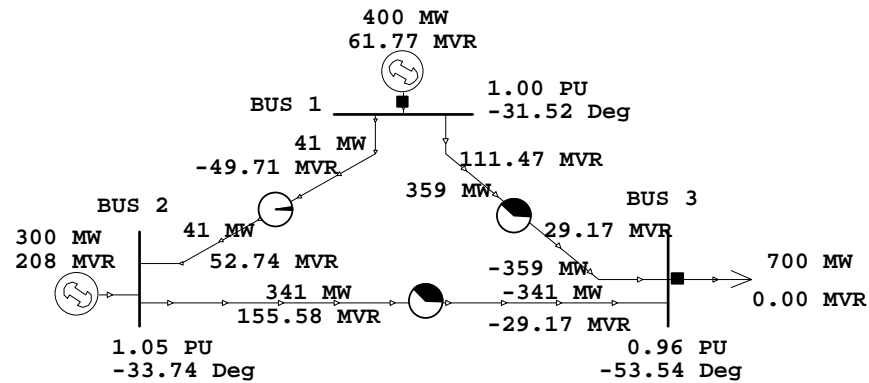

Figure 6.14. The new operating point with a satisfactory voltage profile

Example 6.5:

Case 5.a:

At first, we assume that the two generators at buses 1 and 2 are owned and controlled by a single entity whose objective is to dispatch its generation units to serve the 700 MW load at bus 3 in the least-cost manner. We assume that the generator at bus 1 has a constant marginal production cost of \$20/MWh up to its full capacity of 500MW. The unit at bus 2 is more expensive and has a constant marginal production cost of \$30/MWh. We also assume that the generator at bus 1 is subject to a generation capability constraint as shown in Figure 6.11, while the generator at bus 2 has sufficient capacity for both real and reactive production so that its generation capability limit never becomes active.

From an economic viewpoint, the operator should dispatch the low marginal cost unit at bus 1 to its full capacity and use the expensive unit at bus 2 to serve the remaining 200 MW of the load. The total production costs would be \$16,000 (500x\$20+200x\$30). As illustrated in Figure 6.13, however, this dispatch will result in the voltage constraint violations at buses 1 and 3 because once the generator at bus 1 is at its full MW capacity, it is unable to provide any MVAR reactive support. The unit at bus 1 needs to provide 81 MVAR to keep its voltage set-point at 1.0 p.u.

The voltage set-point of the unit at bus 2 was already set to its highest value. This means that to improve the voltage profile at the present operating point, the generator at bus 1 must provide reactive support. However, to be able to provide the required reactive support, the real power output of the unit has to be reduced. Then, the dispatcher has to shift real power production from the cheap unit at bus 1 to the expensive unit at bus 2 so that the unit at bus 1 can increase its reactive power capacity to meet the reactive power requirement for improving the voltage profile.

The output from the unit at bus 1 must follow the generation capability constraint curve in Figure 6.11 to minimize the reduction in its real power generation. The power flow results in Figure 6.13 indicate that the dispatcher has to shift 100 MW production from unit at bus 1 to unit at bus 2 so that the unit at bus 1 can produce 62 MVAR to hold its voltage at 1.0 p.u. A satisfactory voltage at bus 3 is obtained as well. Consequently, the total production costs are increased to \$17,000. The \$1,000 additional cost may be considered the cost to the dispatcher in providing the reactive support to meet the voltage requirement.

Case 5.b

In this case, we assume that the three-bus system is operated in a competitive generation market with centralized bid-based dispatch (such as the Poolco market model). Each of the competitive generators at buses 1 and 2 submits to the system operator its bid consisting of the price function of MW output and available capacity. Basing on received bids, the system operator determines both the least-cost dispatch to meet the demand and the corresponding system marginal price, without taking the transmission constraint into consideration. In this market, any generation is paid at the system marginal price.

Now we assume that each generator bids at its marginal cost. The optimal dispatch schedule is shown in Figure 6.15 and the system marginal price is \$30/MWh. As indicated in Figures 6.13 and 6.14, however, the actual generation outputs have to deviate from this dispatch to meet the voltage requirement. The unit at bus 1 is “constrained off” by 100 MW to provide reactive support, and the unit at bus 2 is “constrained on” by 100 MW to replace the reduction at bus 1.

Based on bids submitted by the generators and the resulting system marginal price, the dispatcher determines that the profit of the generator at bus 1 is decreased by \$1,000. We call these lost profits the opportunity costs incurred by the generator in providing the reactive support service. It is the market value of the lost opportunity the generator has to forgo to provide the system-required reactive support.

To provide sufficient incentives to the generator at bus 1 to provide the needed reactive support, the dispatcher must compensate the generator for the opportunity costs. Hence, while the generator is paid at the market clearing price of \$30/MWh for the 400 MW it actually produces, it should be compensated for the lost profit of \$1000 for the 100 MW that it is scheduled but unable to produce. Then, the generator at bus 1 completely recovers its opportunity costs. In other words, the generator would be indifferent to either producing 500 MW and zero MVAR or producing 400 MW and 62 MVAR, since the total profits in both cases are identical, \$5,000. Since the computation of the opportunity costs is totally based on submitted bids and the dispatcher has no access to the generator’s true cost information, the generator may bid strategically to maximize its profit.

In addition, a dispatcher in a large system may have multiple choices for redispatching generation to relieve a voltage violation. As a result, the opportunity costs of reactive support incurred by any one generator will depend on the way the system is redispatched. Also opportunity costs incurred by a generator are different from capacity or operation costs in that opportunity costs are not only dependent on the generator’s physical characteristics, but also on the electricity market

structure and condition. Moreover, *a priori* quantification of the opportunity cost is difficult and uncertain. Since the assertion of a potential opportunity is difficult to verify, the actual opportunity cost should be determined after-the-fact. In general, whenever a generator loses

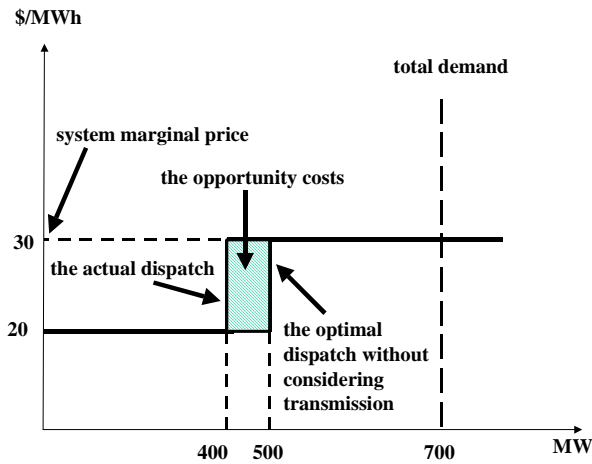

Figure 6.15 The opportunity costs of reactive support

valuable opportunities in the real power market to provide reactive power support, the market value of this lost opportunity may be a key component in the cost structure.

Pricing the Service

As discussed in the previous sections, the unique physical and cost characteristics of reactive support make acquiring and pricing the reactive support ancillary service from independent generators a complicated issue. There are a number of key considerations in acquiring and pricing reactive power support service.

1. Due to its critical importance to the system operation, reactive support service must be available at anytime and at any place where it is needed.
2. The system operator's objective of pricing reactive support service is to give incentives to the generators capable of providing this service to ensure that sufficient and effective reactive support is always available. Hence, the pricing signals for reactive support service should be designed so that any costs incurred by generators in providing the service (including opportunity costs) are compensated.
3. If a market for reactive support service exists, the local nature of reactive support requirements will make this market geographically small. As a result, individual generators may easily manipulate the reactive power prices. Therefore, while other ancillary services (such as reserves and AGC) may be procured from a short-term competitive market, acquiring reactive support service should be based on long-term contracts between the system operator and generators. This market organization allows the system operator to develop alternative reactive support resources to mitigate the gaming behaviors of strategically-located generators.

7

MARKET POWER IN PROVIDING REACTIVE SUPPORT SERVICES

7.1 Background

One of the key aspects of reactive power support as an ancillary service is that reactive power needs are mainly met locally. As a result, the number of providers of reactive power that are capable of supplying the power at any given location is generally small. When only a small number of competing providers are able to provide any one service, this is said to be a situation of “market power” as indicated by high market concentration in this case. For reactive power, the market concentration will necessarily vary by location. There are a number of questions that should be considered in measuring market concentration.

- How many distinct suppliers of reactive power are capable of supplying the necessary reactive power for a given location?
- What is the relative effectiveness of each?
- What is the amount that they are capable of providing?

In brief, if many suppliers can provide reactive power at a given site in sufficient amount, there is no market concentration. If only one or two suppliers can provide EFFECTIVE (not just nominal) amounts of reactive power at a given location, there is market concentration. A measure of market concentration is DIFFERENT from a measure of mere amount. You can have situations where there are ample reactive resources but a lot of concentration. You can have situations where the converse is true: many suppliers, but not enough resources nevertheless.

7.2 Measuring Reactive Market Power

Market power refers to the concentration of resources in the hands of a single producer or an insufficient number of producers. One of the most common means for measuring market power is the Herfindahl-Hirschman Index (H) [59]. This index is defined as follows:

$$H = \sum_{i=1}^N s_i^2 \quad (7-1)$$

where the summation is over all N participants in the market and s_i refers to the market share of each participant. The share can be expressed in per unit or in percentages (in which case the maximum value of H is 10,000). The latter is more common, and is used here¹.

Other measures of market concentration are possible. Two other common measures of concentration are the four-firm and eight-firm concentration ratios (defined as the fraction of the total market held by the four or eight largest firms). Yet another index is the entropy coefficient E , defined as:

$$E = \sum_{i=1}^N \log_2 \left(\frac{1}{s_i} \right) \quad (7-2)$$

Each market concentration index has advantages and disadvantages. It is impossible to establish a clear value below or above which market power exists for any index². Many other aspects of a market not directly captured by these indices (most notably, ease of entry into a market) play heavily into the significance of specific quantitative values of an index. The greatest usefulness of these indices may be their value as relative market power indicators: the larger the value of H the greater the market concentration (and therefore the *potential* for greater market power).

The true measure of market power is the ratio between actual prices and the prices that would arise from true marginal cost pricing. This section considers only market power as measured by H . Other efforts that study the effect of market power on electricity markets are given in [61-63]. A simulation analysis of the effect of network constraints on non-perfect markets can be found in [64].

Because reactive power is of such localized nature, market power considerations can play an even greater role on reactive power than on active power. This section addresses the specific issue of how to use market power ideas to measure market power in the provision of reactive power support service, and proposes a simple measure to quantify market power concerns associated with reactive power.

Reactive power can be provided by any of a number of means such as:

- Shunt capacitors and switched shunt capacitors,
- Synchronous condensers,

¹ H has the interpretation that $n = \frac{1}{H}$ (H in per unit) is the *equivalent number of equal-sized competing firms that are participating in a given market*. Thus, a value of H equal to 2,500 indicates that there are four equal-sized firms in active competition.

² However, the US Department of Justice issues and revises guidelines for mergers [60]. These guidelines rely on the use of the H to determine appropriate conditions that indicate market concentration. According to these guidelines, "the Agency divides the spectrum of market concentration as measured by the H into three regions that can be broadly characterized as unconcentrated (H below 1,000), moderately concentrated (H between 1,000 and 1,800), and highly concentrated (H above 1,800)."

- Synchronous generators, and
- Static VAR compensators.

Because reactive power does not travel very far, it is usually necessary to produce reactive power close to where it is needed. Thus, the opportunity for market power arises as a result of the limited number of potential suppliers.

An additional concern is that the ability to provide reactive power is not an all-or-nothing proposition, but it is rather a matter of degree. A supplier close to a location where the need occurs is in a much better position to provide reactive power than one that is located far from this location. Further complicating the issue is the observation that reactive power supplies are in many cases closely tied to the ability to deliver active power. In this section we do not consider the value of reactive power in terms of active power effects it has. Rather, we concentrate exclusively on the issue of determining how many suppliers are able to regulate the voltage at any location, and to use market power-like indices to measure the degree to which this is possible.

There are a number of desirable features in an index of market concentration for reactive power services.

- It should be simple to compute.
- It should incorporate the locational nature of reactive power. A single index for the whole system is unlikely to be useful.
- It should adapt to changing conditions.

Based on these general objectives, the following approach is proposed for measuring market concentration.

1. Solve a base case power flow.
2. Evaluate the Jacobian at the operating point.
3. For every location of interest in the system, determine the sensitivity of the voltage at that location with respect to the reactive power injection at every generator in the system.
4. The size of available control for a given generator at a particular location is the product of the available generator reactive capability ($Q^{\max} - Q^{\min}$) times the ability of that generator to supply the necessary reactive control at that location, from above.
5. The market power indices are then computed for any location based on this measure.

This index measures the degree of market concentration at any location based on the actual ability of separately owned suppliers to control the voltage at that location for specific system conditions. It does not take into consideration issues having to do with limits already reached and other such issues. Also, a small degree of market power does not necessarily mean that the reactive power resources are adequate, just that there are an adequate number of suppliers able to provide it.

Numerical Example

We now proceed to test this idea in an actual system and see what kind of predictions are obtained. As a test case we use the IEEE 118 bus test system. Table 7.1 illustrates some features of this system.

Table 7.1 Characteristics of the test system

Number of buses	118
Number of lines	188
Total active load (MW)	3,688
Total reactive load (MVAR)	1,438

For purposes of this example, it is assumed that only generators are able to supply reactive power. This is a gross underestimate of the resources available for reactive power control, but it makes the illustration of the nature of the proposed index easier.

Also, it is assumed that a subset of 15 are selected as possible participants. All generators in the market have the same nominal ability to supply reactive power. The reactive power range for any one unit ranges from -50 MVAR up to +150 MVAR, for a dynamic range of 200 MVAR. This range is used for all the calculations.

A total of six distinct arbitrary locations are selected for analysis. Table 7.2 illustrates the sensitivities as computed from the Jacobian for each generator at each location. Computation of the H for each location follows the usual formula, except that the size of the participants (200 MVAR assumed for all) is first scaled by their ability to contribute to the control, as obtained from this table. The end results of the H computation are given in the last line of Table 7.2.

Although there are many competing generators in this system, this table shows that the H can be high for some locations, suggesting excessive reactive power market concentration. Since reactive resources are relatively easy to add to a system, these results suggest locations where additional resources could be added to reduce market concentration. Other considerations in adding reactive power sources were presented in Section 2.

A simple index to measure the degree of reactive power market concentration at any one location has been presented and tested. Using a test case, the index and sensitivities to it convey insightful information about the ability of independent suppliers to compete in the supply of reactive power and voltage control to any one location. Additional work needs to be done before this index can be adopted for general use. However, as a minimum this index has been useful to indicate locations within the grid where market concentration of reactive power resources is of relatively more significant concern, and where the addition of independently-owned reactive resources may prove most valuable in reducing market concentration.

Table 7.2 Distance sensitivity factors (%) and H for 6 locations

Generator	Location					
	A	B	C	D	E	F
1	19.1	11.1	0.0	0.0	70.7	0.0
2	3.2	3.0	0.0	0.0	0.0	0.1
3	1.8	1.6	0.0	0.0	0.0	0.0
4	8.7	13.4	0.0	0.0	0.0	2.4
5	4.1	2.2	0.0	0.0	0.0	0.0
6	0.0	0.0	19.3	0.0	29.3	71.2
7	8.0	14.5	0.1	0.0	0.0	8.0
8	4.2	8.6	7.5	0.0	0.0	10.1
9	9.7	7.5	0.0	0.0	0.0	0.0
10	7.3	5.9	0.0	0.0	0.0	0.0
11	0.0	0.0	68.4	0.0	0.0	0.0
12	16.7	16.9	0.0	0.0	0.0	2.5
13	6.1	4.2	0.0	50.6	0.0	0.0
14	1.0	4.0	4.8	49.3	0.0	5.7
15	10.1	6.3	0.0	0.0	0.0	0.0
H	1119.6	1056.3	5122.6	4999.6	5857.7	5285.7

8

DYNAMIC ASPECTS OF REACTIVE POWER

8.1 General Concepts

Reactive power needs are not static. There are important dynamic aspects to reactive power needs. How quickly reactive power is provided is important as is how rapidly a generating unit providing reactive power is able to respond to a signal calling for reactive power support.

The objective of this section is to contribute to the understanding of how to measure and classify reactive power support services from the viewpoint of “frequency domain” analysis. Specifically, it is assumed that reactive power needs are associated with variations in load and generation. The amount of reactive power required is a function of the variation of the supply or the demand in an appropriate time frame.

As we have already seen, reactive power support is the result of several system requirements.

1. Loads can have a low power factor. A low power factor at a load requires the injection of a corresponding reactive power flow at some location.
2. As a result of their shunt capacitances, cables, and to some extent lines, inject reactive power into the system. Under low load conditions, an imbalance in reactive power can take place.
3. Flows in lines or cables “consume” reactive power.

Of these three, items 1 and 2 are likely to result in relatively slow variations in reactive power balance. However, item 3 can result in sudden changes in reactive power requirements if loads are subject to sudden change.

Deliberate means to adjust the reactive power balance in the network requires the installation of equipment that alters the reactive power balance. This equipment comes in three main categories.

1. Switchable shunt devices, such as capacitors and reactors. These devices can change their reactive power output only in discrete amounts at discrete points in time. They are generally considered to be “slow responding.”
2. Generators can provide reactive power, and they are most often used to adjust the reactive injection at generator locations to maintain voltage levels principally at the generator buses.
3. Electronic devices, such as Static VAR and STATCOM devices, can have their reactive power output adjusted quite rapidly within their capability range.

Changing tap positions in transformers also affects the reactive power balance in the system. Finally, changes in active power injection can alter the reactive power balance, but are generally considered an ineffective means for attaining such adjustments.

8.2 Time Domain vs. Frequency Domain

This section describes a method for characterizing the variability of reactive demand and reactive supply. Time variability of any signal can be characterized both in time and frequency domains. One of the most common characterizations of a signal in the time domain is the “ramping rate,” which is a measure of how rapidly a signal changes as a function of time: the time derivative of the function, or the incremental change in signal value over a predefined period. Another common time domain characterization is the time delay in a device’s response: if a device must “wait” a certain period before changing its status. Yet a third time domain characterization involves the concept of the time constant of the ability to respond to a change (assuming, of course, the primary effect is first order).

An alternative to time domain characterizations of signals is their corresponding frequency domain characterization. Subject to certain limitations imposed by sampling frequencies in the case of discrete-time signals, a frequency domain characterization of any signal can be complete. A complete frequency domain signal perfectly reconstructs the original time domain signal. Frequency domain characterizations have the advantage that it is much easier to “separate” signals into their “fast” and “slow” components. Classification of what portions of a signal are “fast” and what portions are “slow” is much harder to define in the time domain.

The time domain characterizations are perhaps more intuitive characterizations of dynamic reactive power needs. However, it is possible to characterize variability in *loads* and *sources of reactive supply* in the frequency domain.

- Because it is relatively straightforward to characterize demand in terms of its time variability characteristics, a time domain characterization of all types of *loads* seems both natural and appropriate. A load requires a certain amount of reactive power to be delivered to it. A load also creates the need for additional reactive power as a result of the flows it induces in the grid. The variable that we will use to characterize the reactive demand associated with a load will be the value of total system demand needed to maintain a given system voltage profile as the load varies over its cycle. Once a time domain characterization of the reactive demand has been attained for a load, this characterization can be transformed into the frequency domain by means of a simple Fourier transformation.
- *Sources of reactive supply* can be characterized directly in the frequency domain if their frequency response characteristics are known. Also, rather than an exact characterization, it is sufficient to obtain a classification of reactive supply sources. For example, assume that a shunt capacitor bank of a given size can be switched on and off with a cycling period of no less than every 5 minutes. This gives us the ability to model its frequency response characteristics as a $1/(5*60)$ Hz response. For reactive power supplied by generators, the time constants associated with the response of the voltage regulator determine the frequency spectrum classification. Since these time constants are likely to be in the order of a few

seconds, in the frequency domain, a generator is able to supply reactive power at about 0.1 Hz. Finally, electronic sources of reactive power (such as static VAR compensators and STATCOMs) have time constants down to a cycle or less. Thus, they are able to supply reactive power in the “greater than 1 Hz” range.

Similarly, reactive power dynamic needs can also be classified in the frequency domain. We propose a three-way classification.

- Reactive power needs in the cycle time frame, associated with variations with periods of one cycle to one second (frequencies down to 0.1 Hz). These needs can only be met by electronic means.
- Reactive power needs in the multi-second time frame, associated with variations in reactive power with time constants in few seconds to the few minutes (frequency domain needs in the range of 0.1 Hz down to 0.001 Hz). These needs can be met either by electronic means or by means of synchronous machines.
- Reactive power needs slower than a few minutes (below 0.001 Hz). These needs can be met by ordinary switched capacitor banks.

Another issue of significance is the notion of “threshold.” Reactive power is needed to maintain voltages between certain ranges. In reality, there is latitude about the precise voltage levels that one needs to maintain. Below a certain threshold, there is simply no need to provide the service. This is particularly true of fast needs. When the need for fast reactive response is below the threshold, there is no need to address the issue. The threshold for reactive needs in fast time frames is often set in relation to levels of perception. Levels of perception vary within the frequency domain. A 0.01 p.u. voltage variation in the 0.5 second time frame can give rise to extremely annoying visual effects in lighting applications, while the same voltage variation in a slow time frame is all but unnoticeable.

8.3 An Example

For purposes of this section, we consider a simple specific example. The example involves a five-bus system where one load may be of the following three types:

1. A slowly varying PQ load that cycles smoothly as the load rises and falls with a daily pattern.
2. A slowly varying PQ load that cycles daily but where there is a significant random component to the load variation.
3. A purely resistive load that varies abruptly and at random intervals between two values: zero and an value of 50 MW (emulating the characteristics of, for example, arc furnaces). The mean on period for this load is 60 seconds whereas the mean off period is 120 seconds.

For each type of load, we determine the total system reactive power needs necessary to maintain the voltages at the “given” value. The given value is the value of the voltages at any operating condition. Since the needs are primarily dictated by departures from this condition, the exact

base case conditions are not that relevant. Once the total system needs are determined for the reactive power, a spectral analysis of these needs is performed and conclusions are drawn.

At this point we move into the specifics of the example. The system of interest is illustrated in Figure 8.1. The load of interest is located at bus 3.

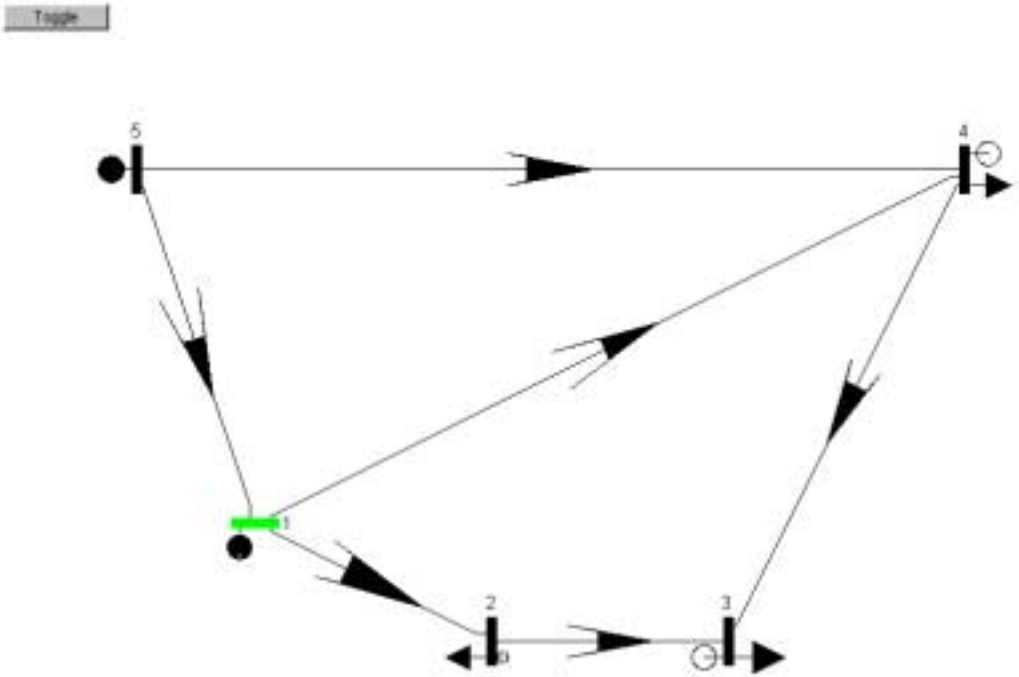

Figure 8.1 The system of interest with the variable load located at bus 3

The three types of loads that are applied to bus 3 are illustrated in Figures 8.2, 8.3 and 8.4 respectively. Figure 8.5 illustrates the variation in individual bus reactive power needs as the demand at bus 3 varies from its nominal level of 300 MW to a value of 500 MW, with all other locations held at a constant level.

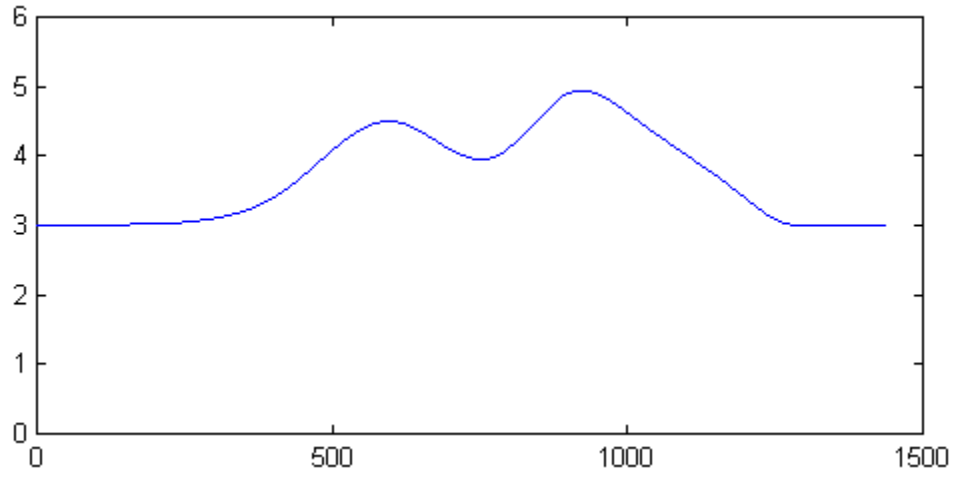

Figure 8.2 Type 1 load, slow daily variation. Horizontal axis is in minutes.

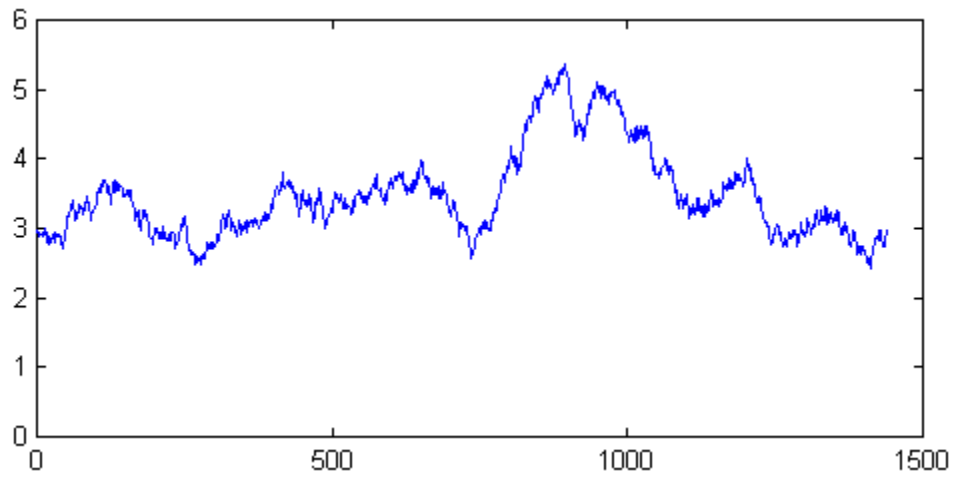

Figure 8.3 Type 2 load, slow daily variation with rapid random values superimposed.

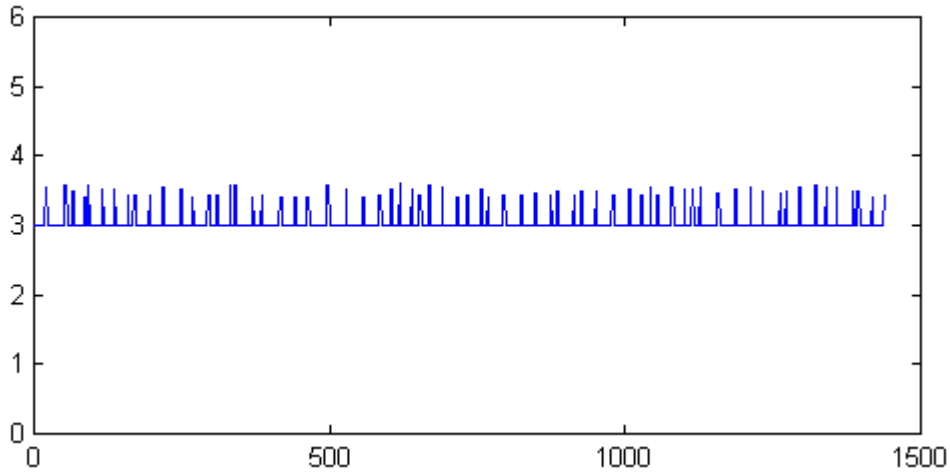

Figure 8.4 Type 3 load, constant load with random sudden on/off (jump process) load applied.

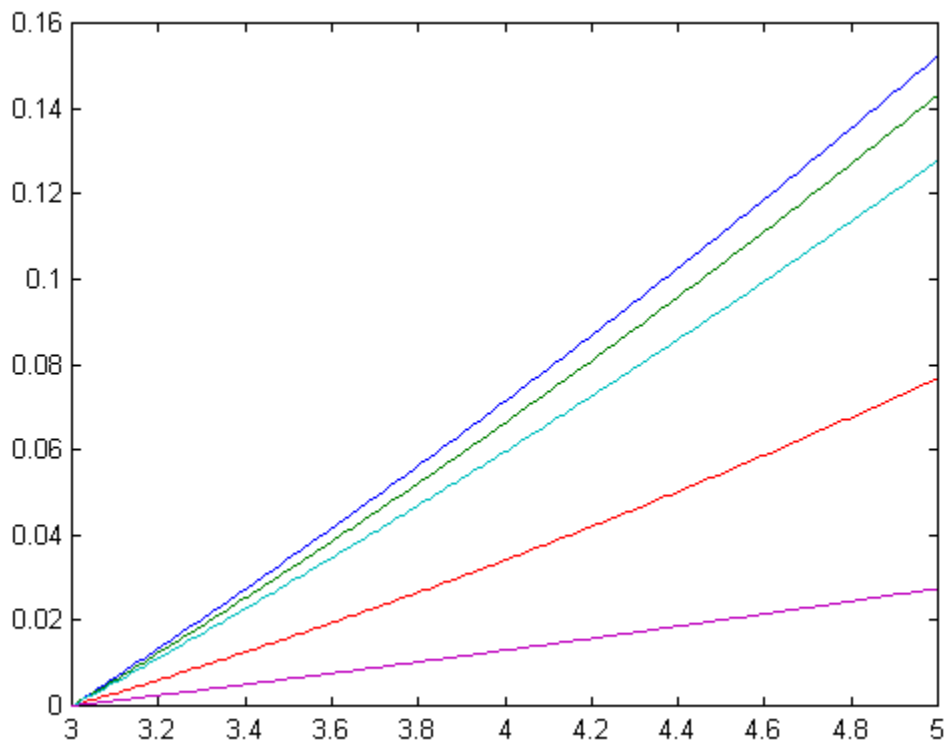

Figure 8.5 Variation in individual reactive power demand needs as a function of the demand level at location 3. Total reactive demand is the sum of individual demands.

It is the sum of these individual needs that is used to determine the total reactive power needs of the system. The reactive power needs are obtained by translating the individual load variations into total reactive power requirements to maintain the desired load profile. This determines a

time-domain variation for the reactive power needs for each load type. This time variation is then decomposed into the frequency domain by performing a Fourier transformation of the reactive power requirements. The frequency spectrum is then classified by putting the spectral content of the reactive requirements into the three groups. The spectral decomposition of the reactive power needs for each of the three load types is illustrated in Figure 8.6. In this example, the thresholds dividing the three frequency domains have been set somewhat arbitrarily. With this caveat, however, it can be seen that the reactive demands due to slow load variations can be entirely met with slow-switching devices. The needs arising from type 2 requirements can be met mostly using slow devices, but synchronous machines also become necessary. Finally, the needs for the “arc-furnace” type load must be met almost entirely using fast-acting reactive power sources. This analysis permits the formal quantification of these needs.

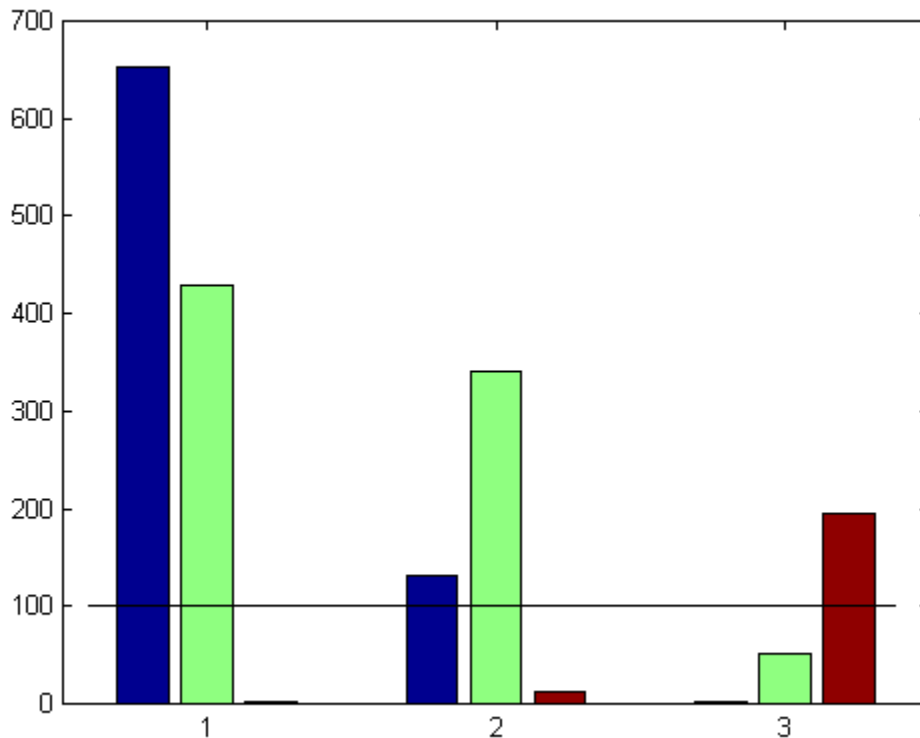

Figure 8.6 Bars represent relative needs for reactive power dynamic requirements. Leftmost group corresponds to “slow mode” needs (switched capacitors are sufficient). Middle group represents mid-term needs (synchronous machines are ok). Rightmost group corresponds to fast needs. Within each group, the bars correspond to types 1, 2 and 3 loads respectively. A possible “threshold level” is also illustrated.

Frequency domain analysis provides a rational and reasonable way of measuring the dynamic aspects of reactive power requirements in a system, and for allocating these needs among the various parties requiring them. When combined with methods for allocation of reactive power needs described in sections 4, 5 and 6, it allows us to allocate reactive power by customer. More significant, however, is that this analytical method permits the classification of need according to the type of equipment necessary to meet the need.

CONCLUSIONS AND SUGGESTIONS FOR FUTURE RESEARCH

9.1 Conclusions

The pricing and costing of reactive power and voltage control services has many aspects. This research has focused on issues associated with reactive power placement, nodal pricing, third-party support, reactive loss allocation, value and cost, reactive market power, and dynamic response considerations. New results have been obtained for each of these issues and provide new techniques for pricing and costing reactive power and voltage control services.

The results on reactive power placement provide a method to rank alternative reactive power placement options. The method is based on Cost Benefit Analysis and Optimal Power Flow. The results indicate that alternative sites for reactive power placement can be evaluated in a systematic manner to assist in decision for investing in reactive power resources.

Optimal Power Flow methods were developed to reveal the value of reactive power sources through their ability to enable (or prevent) real power transactions. As such, the value of reactive power sources is provided in terms of their affects on real-power locational pricing. An example of the impact of capacitor bank sizing shows the possible impact of reactive power support for real-power transfers.

The investigation of third-party reactive power support issues indicates that there is a basis for determining reactive power requirements needed from multiple parties to support bi-lateral transactions. This is shown to be especially important in cases where margin to voltage collapse must be preserved for security purposes.

In considering the voltage support issues, the allocation of reactive power losses is an equivalent problem which can be formulated in a manner similar to real-power loss allocation. The research compared a simple pro-rata approach, an incremental average approach, the Aumann-Shapley approach, and a unique flow-based approach. While each of these approaches provided slightly different reactive power allocations, the basic results were actually quite similar. Since there is no method that can be declared the “exact” allocation, the question of which allocation methodology to use is not critical.

In relating the value and cost of reactive power, the major issue was lost opportunity for real-power generation and associated transactions. The local nature of reactive power support requirements indicated that there may not be a strong basis for allocating reactive power support with generators involved in real-power transactions. That is, examples show that voltage support

is easier from some locations than others. The voltage control and reactive power dispatching must therefore be done on a system-wide basis rather than directly tied to individual transactions. Thus the cost of providing reactive power support may be significantly different from the value that the supply brings to the system.

One of the most interesting issues of this research dealt with the question of reactive power market power. With the local nature of reactive power support, key locations can be identified for voltage control functions. These locations were identified in this work through the use of the Herfindahl-Hirschman Index (HHI). The results provide information on which locations are most able to provide voltage control. These locations then could be considered to have market power for this service.

The issue of dynamic response was examined from a frequency response approach. With the varying ability of reactive power sources to respond to fast or slow load requirements, the frequency response analysis provides a quantitative spectrum of requirements for different types of loads. These results can be used to provide the appropriate mix of reactive power resources to most effectively meet load demands.

This research has considered standard reactive power pricing techniques based on percentage of capital equipment expenditure and new techniques based on optimal power flow and other allocation methods. The results indicate that while costing of reactive power tends to be rather predictable in terms of resource investment, the pricing can be justified over wide ranges that reflect the value that the service provides to enable real-power transactions.

9.2 Suggestions For Future Research

Throughout this work, many new concepts were proposed based on issues that were identified through small example simulations. Even for these small examples, concrete costing and pricing strategies remain subject to interpretation and debate. The ideas have not yet been tested for their compatibility with regulatory laws and operator practices. As such, there is additional research needed in many of the above areas to refine the options proposed and to develop detailed algorithms that can be used in the marketplace with the approval of FERC and NERC. The software codes that were utilized to produce the results given in the report need to be implemented in commercial products before being applied in actual systems.

REFERENCES

- [1] Attendees Notebook, "Ancillary Services Workshop: Measurement and Costing of Ancillary Services in Emerging Market Structures," Held in Miami Florida by the Electric Power Research Institute, Palo Alto, CA, December 10-11,1997.
- [2] R. A. Wakefield, H. D. Limmer, D. J. LeKang, and J. S. Graves, "Transmission Services Costing Framework," EPRI Report TR-105121-V1 and V2, Electric Power Research Institute, Palo Alto, CA, April 1995.
- [3] K. N. Zadeh and R. C. Meyer, "Proceedings: Forum on Ancillary Services," EPRI Report TR-105686, Electric Power Research Institute, Palo Alto, CA, September 1995.
- [4] S. F. Szwed, G. K. Luciano, D. C. Konieczkowski, R. A. Wakefield, D. J. Lekang, "Application of EPRI's Transmission Services Costing Framework to the Development of Open Access Transmission Tariffs," EPRI Report TR-105971, Electric Power Research Institute, Palo Alto, CA, January 1996.
- [5] D. Curtice, "Cost of Providing Ancillary Services from Power Plants," EPRI Report TR-107270-V1, Electric Power Research Institute, Palo Alto, CA, March 1997.
- [6] P. J. Turner and R. J. Nicholls, "Cost of Providing Ancillary Services from Power Plants: Reactive Supply and Voltage Control," EPRI Report TR-107270-V3, Electric Power Research Institute, Palo Alto, CA, June 1997.
- [7] L. D. Kirsch, D. Armstrong, K. Driessens, and C. Herrera, "Survey of Unbundled Electric Power Services," EPRI Report TR-109461, Electric Power Research Institute, Palo Alto, CA, February 1998.
- [8] E. Hirst and B. Kirby, "Electric-Power Ancillary Services," ORNL/CON-426, Oak Ridge National Laboratory, Oak Ridge, Tennessee, February 1996.
- [9] B. Kirby and E. Hirst, "Ancillary Service Costs for 12 U.S. Electric Utilities," ORNL/CON-427, Oak Ridge National Laboratory, Oak Ridge, Tennessee, March 1996.
- [10] E. Hirst and B. Kirby, "Creating Competitive Markets for Ancillary Services," ORNL/CON-448, Oak Ridge National Laboratory, Oak Ridge, Tennessee, October 1997.
- [11] B. Kirby and E. Hirst, "Ancillary Service Details: Voltage Control," ORNL/CON-453, Oak Ridge National Laboratory, Oak Ridge, Tennessee, December 1997.
- [12] John W. Lamont and Jian Fu, "Cost Analysis of Reactive Power Support", PE-298-PWRS-0-04-1998, To appear, *IEEE Transactions on Power Systems*.
- [13] M. L. Baughman and S. N. Siddiqi, "Real-Time Pricing of Reactive Power: Theory and Case Study Results", *IEEE Transactions on Power Systems*, Vol. 6, No. 1, February 1991, pp. 23-29.

- [14] M. Rivier and I. Perez-Arriaga, "Computation and Decomposition of Spot Prices for Transmission Pricing," *Proceedings of the 11th Power System Computation Conference (PSCC)*, Avignon, France, August 1993.
- [15] Tabors, R. D., "Transmission System Management and Pricing: New Paradigms and International Comparisons", *IEEE Transactions on Power Systems*, Vol. 9, No. 1, February 1994, pp. 206-215.
- [16] Kahn, E. And R. Baldick, "Reactive Power is a Cheap Constraint", *The Energy Journal*, Vol. 15, No. 4, 1994.
- [17] I. J. Perez-Arriaga, F. J. Rubio, J. F. Puerta, J. Arceluz, and J. Marin, "Marginal Pricing of Transmission Services: An Analysis of Cost Recovery," *IEEE Transactions on Power Systems*, Vol. 10, No. 1, February 1995, pp. 546-553.
- [18] M. Muchayi and M. El-Hawary, "A summary of algorithms in reactive power pricing," *Proceedings of the Canadian Conference on Electrical and computer Engineering*, 1995, pp. 692-696
- [19] D. Chattopadhyay, K. Bhattacharya, and J. Parikh, "Optimal reactive power planning and its spot-pricing," *IEEE Transactions on Power Systems*, Vol. 10, No. 4, November, 1995, pp. 2014-2020.
- [20] Mitsche, J., "Real and Reactive Power Marginal Costs", *Power Technology*, Issue No. 86, Third Quarter 1996, Power Technologies Inc., Schenectady, NY, 1996.
- [21] L. F. Willis, F. Finey, and G. Ramon, "Computing the Cost of Unbundled Services, *IEEE Computer Applications in Power*, October, 1996, pp. 16-21.
- [22] J. D. Weber, M. J. Laufenberg, T. J. Overbye, and P. W. Sauer, "Assessing the Value of Reactive Power Services in Electric Power Systems, *Proceedings of the national Science Foundation Conference on Unbundled Power Quality Services in the Power Industry*, November 17-19, 1996, Key West FL, pp., 160-167.
- [23] J. Y. Choi, S.-H. Rim, and J.-K. Park, "Optimal Real Time Pricing of Real and Reactive Powers," Paper PE-037-PWRS-0-10-1997 recommended and approved for publication in the *IEEE Transactions on Power Systems*.
- [24] M. L. Baughman, S. N. Siddiqi, and J. W. Zarnikau, "Advanced Pricing in electrical Systems Parts I&II," *IEEE Transactions on Power Systems*, Vol. 12, No. 1, February 1997, pp. 489-502.
- [25] C. W. Yu and A. K. David, "Pricing Transmission Services in the Context of Industry Deregulation," *IEEE Transactions on Power Systems*, Vol. 12, No. 1, February 1997, pp. 503-510
- [26] A. El-Keib and X. Ma, "Calculating short-run marginal costs of active and reactive power production," *IEEE Transactions on Power Systems*, Vol. 12, No. 2, pp. 559-565.

- [27] Sun, D. I., Ashley, B., Brewer, B., Hughes, A., Tinney, W. F., "Optimal Power Flow by Newton Approach," *IEEE Transactions on Power Apparatus and Systems*, Vol. PAS-103, October 1984, pp. 2864-2880.
- [28] Huneault, M., Galiana, F. D., "A Survey of the Optimal Power Flow Literature," *IEEE Transactions on Power Systems*, Vol. 6, No. 2, May 1991, pp. 762-770.
- [29] L. D. Kirsch and H. Singh, "Pricing Ancillary Electric Power Services," *The Electricity Journal*, Vol. 8, No. 8, pp. 28-36, October 1995.
- [30] Alvarado, F., R. Broehm, L. Kirsch, and A. Panvini, "Retail Pricing of Reactive Power Service", *Proceedings of EPRI Conference*, San Diego, CA, March 28-30, 1996.
- [31] Shirmohammadi, D., Filho, X.V., Gorenstin, B., Pereira, M., "Some fundamental technical concepts about cost based transmission pricing", *IEEE Transactions on Power Systems*, Vol. 11, No. 2, May 1996, pp. 1002-1008
- [32] Alvarado, F. "Methods for the Quantification of Ancillary Services in Electric Power Systems", 1996 Sepope Conference, Recife, Brazil, May 20-24, 1996.
- [33] S. Hao and A. Papalexopoulos, "Reactive Power Pricing and Management", *IEEE Transactions on Power Systems*, Vol. 12, NO. 1, February 1997, pp. 95-104.
- [34] A. Zobian and M. D. Ilic, "Unbundling of Transmission and Ancillary Services, Part I & II," *IEEE Transactions on Power Systems*, Vol. 12, No. 2, May 1997, pp. 539-558.
- [35] S. V. Berg, J. Adams, and B. Niekum, "Power Factors and the Efficient Pricing and production of Reactive Power," *The Energy Journal*, Vol. 4, Special Electricity Issue, pp. 93-102.
- [36] M. E. Baran, V. Banunarayanan, and K E. Garren, "A Transaction Assessment Method for Allocation of Transmission Services," Paper PE-410-PWRS-0-1-1998 recommended and approved for publication in the *IEEE Transactions on Power Systems*.
- [37] A. G. Ward, "Draft Graduate Thesis Chapters and Paper on Ancillary Service Pricing," University of Canterbury, Christchurch, New Zealand.
- [38] R.J. Aumann and L.S. Shapley, *Value of Non-Atomic Games*, Princeton University Press, 1974.
- [39] L. Billera, D.C. Heath, "Allocation of Shared Costs: A Set of Axioms Yielding a Unique Procedure", *Mathematics of Operations Research*, Vol. 7, No. 1, Feb. 1982.
- [40] Fernando L. Alvarado (Convenor), X.Vieira F., S. Granville, M.V.F. Pereira, G. Marzano, J. Soto, A.G.B. Melo, B.G. Gorenstin, J.C. Mello "Methods and Tools for Costing Ancillary Services," CIGRÉ Study Committee 38 Advisory Group 05 Task Force 38-05-07, draft report, May 1999.

- [41] Abdul-Rahman, K.H., Shahidehpour, S.M., and Daneshdoost, M., “AI Approach to Optimal VAR Control with Fuzzy Reactive Loads”, *IEEE Transactions on Power Systems*, Vol. 10, 1995, pp. 88-97.
- [42] Zhu, J.Z., and Chang, C.S., “Power System Optimal VAR Planning with Security and Economic Constraints”, *Proceedings of International Power Eng. Conference, IPEC'97*, Singapore, May, 1997, pp. 42-46
- [43] Shahidehpour, S.M., and Deeb, N., “An Overview of the Reactive Power Allocation in Electric Power Systems”, *Electrical Machines and Power Systems*, Vol. 18, 1990, pp. 495-518.
- [44] Alsac, O., Bright, J., Prais, M., and Stott, B., “Further Developments in LP-Based Optimal Power Flow”, *IEEE Transaction on Power Systems*, Vol. 2, 1990, pp. 697-711.
- [45] Deeb, N., and Shahidehpour, S.M., “Linear Reactive Power Optimization in a Large Power Network Using the Decomposition Approach”, *IEEE Transactions on Power Systems*, Vol. 5, 1990, pp. 428-438.
- [46] Mamandur, K., and Chenoweth, R., “Optimal Control of Reactive Power Flow for Improvements in Voltage Profiles and for Real Power Loss Minimization”, *IEEE Transactions PAS*, Vol. 100, 1981, pp. 3185-3194.
- [47] Mansour, M.O., and Abdel-Rahman, T.M., “Non-linear VAR Optimization Using Decomposition and Coordination”, *IEEE Transactions PAS*, Vol. 103, 1984, pp. 246-255.
- [48] Dandachi, N.H., Rawlins, M.J., Alsac, O., and Stott, B., “OPF for Reactive Pricing Studies on the NGC System”, *IEEE Power Industry Computer Applications Conference, PICA'95*, Utah, May, 1995, pp. 11-17
- [49] Chattopadhyay, D., Bhattacharya, K., and Parikh, J., “Optimal Reactive Power Planning and Its Spot-pricing: An Integrated Approach”, *IEEE PES Winter Meeting, 95 WM 204-8 PWRS*, 1995
- [50] Berg, S.V., Adams, J., and Nickum, B., “Power Factors and the Efficient Pricing and Production of Reactive Power”, *The Energy Journal*, Vol. 4, pp. 93-102
- [51] Momoh, J. A., Zhu, J. “Multiple indices for optimal reactive power pricing and control”, *The International Journal of Decision Support Systems*, Elsevier Science, North Holland, Vol. 24, Nos.3,4, January 1999, pp. 223-232.
- [52] Schweppe, F.C., Caramanis, M.C., Tabors, R.D., and Bohn, R.E., *Spot Pricing of Electricity*, Kluwer Academic Publishers, 1988
- [53] Saaty, T.L., *The Analytic Hierarchy Process*, McGraw Hill, Inc., New York, 1980.

- [54] Zhu, J.Z., and Irving, M.R., "Combined Active and Reactive Dispatch with Multiple Objectives Using Analytic Hierarchical Process", *IEEE Proceedings Part C*, Vol. 143, 1996, pp. 344-352.
- [55] Momoh, J.A., Zhu, J.Z., and Dolce, J.L., "A New Method to Congestion Analysis for Aerospace Power System", *Proceedings of the IEEE 1997 North American Power System Symposium (NAPS)*, October 1997, Wyoming.
- [56] Momoh, J.A., Brown, G.F., Adapa, R.A., "Evaluation of Interior Point Methods and Their Application to Power Systems Economic Dispatch", *Proceedings of the IEEE 1993 North American Power System Symposium (NAPS)*, pp. 116-123, October 1993.
- [57] Momoh, J.A., "Robust Interior Point Optimal Power Flow", EPRI Final Report TR-105081, May 1995
- [58] Shu Tao, *Allocation and Management Issues in Multiple-Transaction Open Access Transmission Networks*, Ph.D. Thesis (George Gross, Advisor), University of Illinois at Urbana-Champaign, August, 2000.
- [59] F. M. Scherer. *Industrial Market Structure and Economic Performance*. Rand McNally College Publishing Company, 1980.
- [60] Justice Department and Federal Trade Commission. Horizontal merger guidelines. Revision issued April 8, 1997, originally issued April 1992.
- [61] W. W. Hogan. A market power model with strategic interaction in electricity networks. *The Energy Journal*, 18(4):107-141, 1997.
- [62] S. S. Oren, Economic in efficiency of passive transmission rights in congested electricity systems with competitive generation. *The Energy Journal*, 18(1):63-83, 1997.
- [63] L. J. Perl. Measuring market power in electric generation. *Antitrust Law Journal*, 64:311-321, 1996.
- [64] Z. Younes and M. Ilic. Transmission system constraints in non-perfect electricity markets, 1989.

BIBLIOGRAPHY OF PROJECT PUBLICATIONS

Fernando L. Alvarado (Convenor), X.Vieira F., S. Granville, M.V.F. Pereira, G. Marzano, J. Soto, A.G.B. Melo, B.G. Gorenstin, J.C. Mello "Methods and Tools for Costing Ancillary Services," CIGRÉ Study Committee 38 Advisory Group 05 Task Force 38-05-07, Final report issued August 2000.

George Gross and Shu Tao, "A Physical-Flow-Based Approach to Allocating Transmission Losses in a Transaction Framework", *IEEE Transactions on Power Systems*, Vol. 15, No. 2, May 2000, pp. 631-637.

J.A. Momoh and J.Z. Zhu, "A New Approach to VAR Pricing and Control in the Competitive Environment," Proceedings of Thirty-First Hawaii International Conference on System Sciences, HICSS'31, Hawaii, Jan., 1998, vol. 3, p. 104.

J.A. Momoh and J.Z. Zhu, "Multiple Indices for Optimal Reactive Power Pricing and Control", *The International Journal of Decision Support Systems*, Elsevier Science, North Holland, Vol. 24, Nos.3 and 4, January 1999, pp. 223-232.

T. J. Overbye, G. Gross, P. W. Sauer, and M. J. Laufenberg, "Market Power Evaluation in Power Systems with Congestion", *Game Theory Applications in Electric Power Markets*, IEEE, Piscataway, NJ, 1999, pp. 61-69.

Shu Tao and George Gross, "Transmission Loss Compensation in Multiple Transaction Networks", *IEEE Transactions in Power Systems*, Vol. 15, No. 3, August 2000, pp. 909-915.

J. D. Weber, T. J. Overbye, P. W. Sauer, and C. L. DeMarco, "A Simulation Based Approach to Pricing Reactive Power", Proceedings of the Hawaii International Conference on System Sciences - Vol. III, Kona, Hawaii, January 6-9, 1998, pp. 96-103.

J. D. Weber, T. J. Overbye and P. W. Sauer, "Simulation of Electricity Markets with Player Bidding", *Proceedings of the Symposium on Bulk Power System Dynamics and Control IV – Restructuring*, Santorini, Greece, August 24-28, 1998, pp. 331-339.

J.Z. Zhu, and J.A. Momoh, "Optimal VAR Pricing and VAR Placement using AHP and OPF Approach," *Proceedings of 1998 Large Engineering Systems Conference on Power Engineering*, LESCOPE'98, Halifax, Canada, vol. 1, 1998, p. 299.

J.Z. Zhu, and J.A. Momoh, "Optimal VAR Pricing and VAR Placement Using Analytic Hierarchical Process," *International Journal of Electrical Power Systems Research*, vol. 47, 1998, p.11.