

# A Virtual Environment for Protective Relaying Evaluation and Testing

A. P. Sakis Meliopoulos  
School of Electrical and Computer Engineering  
Georgia Institute of Technology  
Atlanta, Georgia 30332  
Sakis.meliopoulos@ece.gatech.edu

George J. Cokkinides  
Department of Electrical and Computer Engineering  
University of South Carolina  
Columbia, SC 29208  
cokkinides@attbi.com

**Abstract:** Protective relaying is a fundamental discipline of power system engineering. At Georgia Tech we offer three courses that cover protective relaying: an undergraduate course that devotes one-third of the semester on relaying, a graduate course entitled “Power System Protection” and a three and a half day short course for practicing engineers. To maximize student understanding and training on the concepts, theory and technology associated with protective relaying, we have developed a number of educational tools, all wrapped in a virtual environment. The virtual environment includes (a) a power system simulator, (b) a simulator of instrumentation for protective relaying with visualization and animation modules, (c) specific protective relay models with visualization and animation modules and (d) interfaces to hardware so that testing of actual relaying equipment can be performed. We refer to this set of software as the “virtual power system”. The virtual power system permits the in-depth coverage of the protective relaying concepts in minimum time and maximizes student understanding. The tool is not used in a passive way. Indeed the students actively participate with well-designed projects such as (a) design and implementation of multifunctional relays, (b) relay testing for specific disturbances, etc. The paper describes the virtual power system organization and “engines”, such as solver, visualization and animation of protective relays, etc. It also discusses the utilization of this tool in the courses via specific application examples and student assignments.

**Key Words:** *relaying, time domain simulation, algebraic companion form, visualization, animation*

## Introduction

Relaying has always played a very important role in the security and reliability of electric power systems. As the technology advances, relaying has become more sophisticated with many different options for improved protection of the system. It is indisputable that relaying has made significant advances with dramatic beneficial effects on the safety of systems and protection of equipment. Yet, because of the complexity of the system and multiplicity of competing factors, relaying is a challenging discipline.

Despite all the advances in the field, unintended relay operations (misoperations) do occur. Many events of outages and blackouts can be attributed to inappropriate relaying settings, unanticipated system conditions, and inappropriate selection of instrument transformers. Design of relaying schemes strives to anticipate all possible conditions for the purpose of avoiding non-desirable operations. Practicing relay engineers utilize a two-step procedure to minimize the possibility of such events. First, in the design phase, comprehensive analyses are utilized to determine the best relaying schemes and settings. Second, if such an event occurs, an exhaustive post mortem analysis is performed to reveal the root cause of the event and what “was missed” in the design phase. The post mortem analysis of these events is facilitated with the existing technology of disturbance recordings (via fault disturbance recorders or embedded in numerical relays). This process results in accumulation of experience that passes from one generation of engineers to the next.

An important challenge for educators is the training of students to become effective protective relaying engineers. Students must be provided with an understanding of relaying technology that encompasses the multiplicity of the relaying functions, communications, protocols and automation. In addition, a deep understanding of power system operation and behavior during disturbances is necessary for correct relaying applications. In today’s crowded curricula, the challenge is to achieve this training within a very short period of time, for example one semester. This paper presents an approach to meet this challenge. Specifically, we propose the concept of the virtual power system for the purpose of teaching students the complex topic of protective relaying within a short period of time.

The virtual power system approach is possible because of two factors: (a) recent developments in software engineering and visualization of power system dynamic responses and (b) the new generation of power system digital-object oriented relays. Specifically, it is possible to integrate simulation of the power system, visualization and animation of relay response and relay testing within a virtual environment. This approach permits students to study complex operation of power systems and simultaneously observe relay response with precision and in a short time.

The paper is organized as follows: first a brief description of the virtual power system is provided. Next, the mathematical models to enable the features of the virtual power system are presented together with the modeling approach for relays and relay instrumentation. Finally, few samples of applications of this tool for educational purposes are presented.

## The Virtual Power System

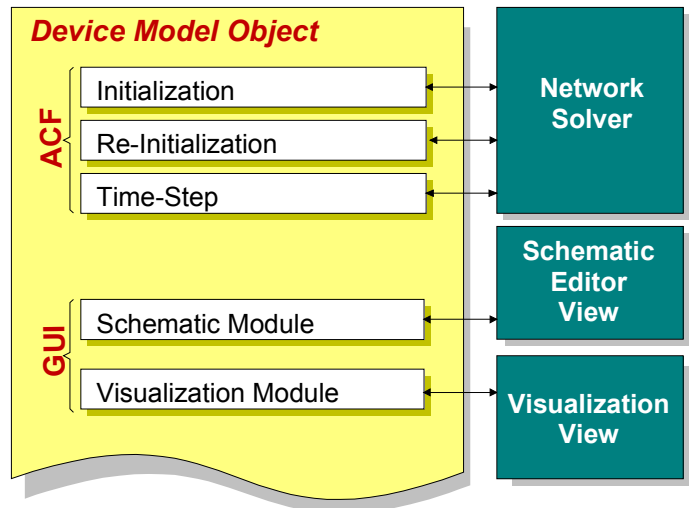
The virtual power system integrates a number of application software in a multitasking environment via a unified graphical user interface. The application software include (a) a dynamic power system simulator, (b) relay objects, (c) relay instrumentation objects, and (d) animation and visualization objects. The virtual power system has the following features:

1. Continuous time domain simulation of the system under study.
2. Ability to modify (or fault) the system under study during the simulation, and immediately observe the effects of the changes.
3. Advanced output data visualization options such as animated 2-D or 3-D displays that illustrate the operation of any device in the system under study.

The above properties are fundamental for a virtual environment intended for the study of protective relaying. The first property guarantees the uninterrupted operation of the system under study in the same way as in a physical laboratory: once a system has been assembled, it will continue to operate. The second property guarantees the ability to connect and disconnect devices into the system without interrupting the simulation of the system or to apply disturbances such as a fault. This property duplicates the capability of physical laboratories where one can connect a component to the physical system and observe the reaction immediately. For example connecting a new relay to the system and observing the operation of the protective relaying logic, applying a disturbance and observing the transients as well as the relay logic transients, etc. The third property duplicates the ability to observe the simulated system operation, in a similar way as in a physical laboratory. Unlike the physical laboratory where one cannot observe the internal operation of a relay, motor, etc. the virtual power system has the capability to provide a visualization and animation of the internal “workings” of a relay, motor, etc. This capability to animate and visualize the internal “workings” of a relay, an instrumentation channel or any other device has a substantial educational value.

The virtual power system implementation is based on the MS Windows multi-document-view architecture. Each document object constructs a single solver object, which handles the simulation computations. The simulated system is represented by a set of objects – one for each system device (i.e. generators, motors, transmission lines, relays, etc). The

document object can generate any number of view window objects. Two basic view classes are available: (a) schematic views and (b) result visualization views. Schematic view objects allow the user to define the simulated system connectivity graphically, by manipulating a single line diagram using the mouse. Result visualization views allow the user to observe calculated results in a variety of ways. Several types of result visualization views are supported and will be discussed later.



**Figure 1. The Virtual Power System Architecture and Model Organization**

Figure 1 illustrates the organization of device objects, network solver and view objects and their interactions. The network solver object is the basic engine that provides the time domain solution of the device operating conditions. To maintain object orientation, each device is represented with a generalized mathematical model of a specific structure, the algebraic companion form (ACF). The mathematics of the algebraic companion form is described in the next section. Implementation-wise, the network solver is an independent background computational thread, allowing both schematic editor and visualization views to be active during the simulation. The network solver continuously updates the operating states of the devices and “feeds” all other applications, such as visualization views, etc. The network solver speed is user selected, thus allowing speeding-up or slowing-down the visualization and animation speed. The multitasking environment permits system topology changes, device parameter changes or connection of new devices (motors, faults) to the system during the simulation. In this way the user can immediately observe the system response in the visualization views.

The network solver interfaces with the device objects. This interface requires at minimum three virtual functions:

**Initialization:** The solver calls this function once before the simulation starts. It initializes all device dependent parameters and models needed during the simulation.

**Re-initialization:** The solver calls this function any time the user modifies any device parameter. Its function is similar to the initialization virtual function.

**Time step:** The solver calls this function at every time step of the time domain simulation. It transfers the solution from the previous time step to the device object and updates the algebraic companion form of the device for the next time step (see next section “network solver”).

In addition to the above functions, a device object has a set of virtual functions comprising the **schematic module** interface. These functions allow the user to manipulate the device within the schematic editor graphical user interface. Specifically, the device diagram can be moved, resized, and copied using the mouse. Also, a function is included in this set, which implements a device parameter editing dialog window which “pops-up” by double clicking on the device icon. Furthermore, the **schematic module** interface allows for device icons that reflect the device status. For example a breaker schematic icon can be implemented to indicate the breaker status.

Finally, each device class (or a group of device classes) may optionally include a **visualization module**, consisting of a set of virtual functions that handle the visualization and animation output. The visualization module interface allows for both 2-D and 3-D graphics. Presently 2-D output is implemented via the Windows *Graphical Device Interface* (GDI) standard. The 3-D output is implemented using the *Open Graphics Library* (OpenGL). Both 2-D and 3-D outputs generate animated displays, which are dynamically updated by the network solver to reflect the latest device state. The potential applications of 2-D or 3-D animated visualization objects are only limited by the imagination of the developer. These objects can generate photo-realistic renderings of electromechanical components that clearly illustrate their internal operation and can be viewed from any desired perspective, slowed down or paused for better observation.

## The Network Solver

Any power system device is described with a set of algebraic-differential-integral equations. These equations are obtained directly from the physical construction of the device. It is always possible to cast these equations in the following general form:

$$\begin{bmatrix} \dot{i}(t) \\ 0 \end{bmatrix} = \begin{bmatrix} f_1(\dot{v}(t), \dot{y}(t), v(t), y(t), u(t)) \\ f_2(\dot{v}(t), \dot{y}(t), v(t), y(t), u(t)) \end{bmatrix} \quad (1)$$

where  $\dot{i}(t)$ : vector of terminal currents,  
 $v(t)$ : vector of terminal voltages,

$y(t)$ : vector of device internal state variables  
 $u(t)$ : vector of independent controls.

Note that this form includes two sets of equations, which are named *external equations* and *internal equations* respectively. The terminal currents appear only in the external equations. Similarly, the device states consist of two sets: *external states* (i.e. terminal voltages,  $v(t)$ ) and *internal states* (i.e.  $y(t)$ ). The set of equations (1) is consistent in the sense that the number of external states and the number of internal equations equals the number of external and internal equations respectively.

Note that equation (1) may contain linear and nonlinear terms. Equation (1) is quadratized, i.e. it is converted into a set of quadratic equations by introducing a series of intermediate variables and expressing the nonlinear components in terms of a series of quadratic terms. The resulting equations are integrated using a suitable numerical integration method. Assuming an integration time step  $h$ , the result of the integration is given with a second order equation of the form:

$$\begin{bmatrix} \dot{i}(t) \\ 0 \end{bmatrix} = \begin{bmatrix} a_{11} & a_{12} \\ a_{21} & a_{22} \end{bmatrix} \begin{bmatrix} v(t) \\ y(t) \end{bmatrix} + \begin{bmatrix} (v^T(t), y^T(t))F_1 \begin{bmatrix} v(t) \\ y(t) \end{bmatrix} \\ (v^T(t), y^T(t))F_2 \begin{bmatrix} v(t) \\ y(t) \end{bmatrix} \\ \vdots \end{bmatrix} + \begin{bmatrix} b_1(t-h) \\ b_2(t-h) \end{bmatrix} \quad (2)$$

where:  $b_1(t-h)$ ,  $b_2(t-h)$  are past history functions.

Equation (2) is referred to as the Algebraic Companion Form (ACF) of the device model. Note that this form is a generalization of the Resistive Companion Form (RCF) that is used by the EMTP [3]. The difference is that the RCF is a linear model that represents a linearized equivalent of the device while the ACF is quadratic and represents the detailed model of the device.

The network solution is obtained by application of Kirchoff’s current law at each node of the system (connectivity constraints). This procedure results in the set of equations (3). To these equations, the internal equations are appended resulting to the following set of equations:

$$\sum_k A^k i^k(t) = 0 \quad (3)$$

$$\text{internal equations of all devices} \quad (4)$$

where  $A^k$  is a component incidence matrix with:

$$\{A_{ij}^k\} = \begin{cases} 1, & \text{if node } j \text{ of component } k \text{ is connected to node } i \\ 0, & \text{otherwise} \end{cases}$$

$i^k(t)$  is the vector of terminal currents of component  $k$ .

Note that Equations (3) correspond one-to-one with the external system states while Equations (4) correspond one-to-one with the internal system states. The vector  $v^k(t)$  of component  $k$  terminal voltages is related to the nodal voltage vector  $v(t)$  by:

$$v^k(t) = (A^k)^T v(t) \quad (5)$$

Upon substitution of device equations (2), the set of equations (3) and (4) become a set of quadratic equations:

$$Ax(t) + \begin{bmatrix} x^T(t)B_1(t)x(t) \\ x^T(t)B_2(t)x(t) \\ \vdots \end{bmatrix} + b(t-h) = 0 \quad (6)$$

where:  $x(t)$  is the vector of all external and internal system states.

These equations are solved using Newton's method. Specifically, the solution is given by the following expression.

$$x^{v+1}(t) = x^v(t) - J^{-1}(Ax^v(t) + \begin{bmatrix} x^{vT}(t)B_1(t)x^v(t) \\ x^{vT}(t)B_2(t)x^v(t) \\ \vdots \end{bmatrix} + b(t-h)) \quad (7)$$

where:  $J$  is the jacobian matrix of equations (6) and  $x^v(t)$  are the values of the state variables at the previous iteration.

## Relay Instrumentation Modeling

Relays and in general IEDs use a system of instrument transformers to scale the power system voltages and currents into instrumentation level voltages and currents. Standard instrumentation level voltages and currents are 67V or 115V and 5A respectively. These standards were established many years ago to accommodate the electromechanical relays. Today, the instrument transformers are still in use but because modern relays (and IEDs) operate at much lower voltages, it is necessary to apply an additional transformation to the new standard voltages of 10V or 2V. This means that the modern instrumentation channel consists of typically two transformations and additional wiring and possibly burdens. Figure 2 illustrates typical instrumentation channels, a voltage channel and a current channel. Note that each component of the instrumentation channel will introduce an error. Of importance is the net error introduced by all the components of the instrumentation channel. The overall error can be defined as follows. Let the voltage or current at the power system be  $v_a(t)$  and  $i_a(t)$  respectively. An ideal instrumentation channel will generate a waveform at the output of the channel that will be an exact replica of the waveform at the power system. If the nominal transformation ratio is  $k_v$  and  $k_i$  for the voltage and current instrumentation channels respectively, then the output of an "ideal" system and the instrumentation channel error will be:

$$v_{ideal}(t) = k_v v_a(t), \quad i_{ideal}(t) = k_i i_a(t)$$

$$v_{error}(t) = v_{out}(t) - v_{ideal}(t), \quad i_{error}(t) = i_{out}(t) - i_{ideal}(t)$$

where the subscript "out" refers to the actual output of the instrumentation channel. The error waveforms can be analyzed to provide the rms value of the error, the phase error, etc.

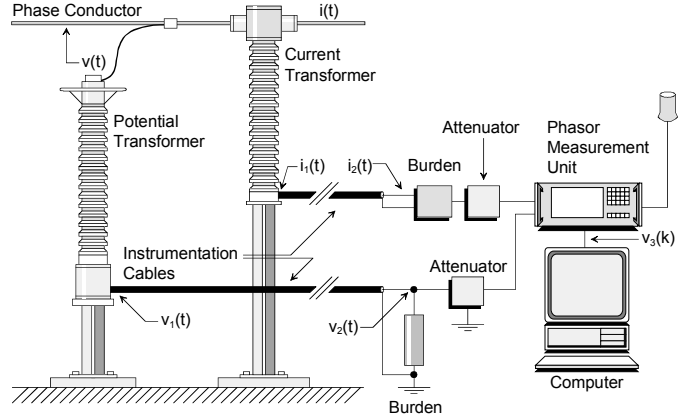


Figure 2. Typical Instrumentation Channel for DFR Data Collection

Any relaying course should include the study of instrumentation channels. The virtual power system is used to study the instrumentation error by including an appropriate model of the entire instrumentation channel. It is important to model the saturation characteristics of CTs and PTs, resonant circuits of CCVTs, etc. (see reference [6]). In the virtual power system, models of instrumentation channel components have been developed. The resulting integrated model provides with precision the instrumentation channel error. With the use of animation methods one can study the evolution of instrumentation errors during transients as well as normal operation.

## Protective Relay Modeling

Today, all new relays are numerical relays. These types of relays can be easily modeled within the virtual power system. Consider for example a directional relay. The operation of this relay is based on the phase angle between the polarizing voltage and the current. Modeling of this relay then requires that the phase angle between the polarizing voltage and the current be computed. For this purpose, as the power system simulation progresses, the relay model retrieves the instantaneous values of the polarizing voltage and the current. A Fourier transform is applied to the retrieved data (a running time Fourier transform over a user specified time window). The result will be the phasors of the polarizing voltage and current from which the phase angles are retrieved. The relay will trip if the phase angle difference is within the operating region. It should be also self understood that, if the relay to be modeled has filters, these filters can be also included in the model.

It is important that students be also involved in the design of numerical relays. A typical semester project is to define the functionality of a specific relay and a set of test cases. The student assignment is to develop the code that will mimic the operation of the relay and demonstrate its correct operation for the test cases.

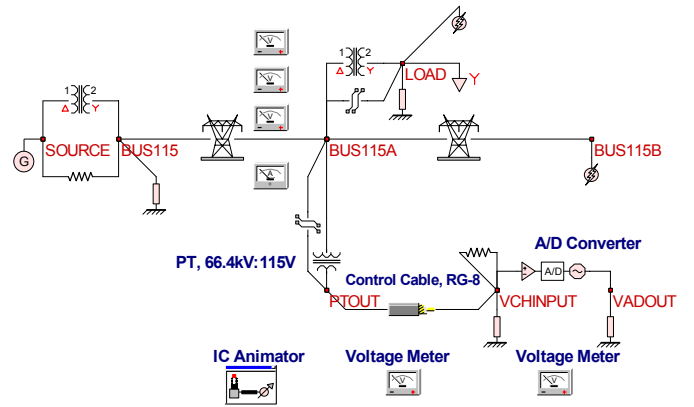
The new technology of the virtual power system offers another more practical way to model relays. The virtual power system uses object oriented programming. As such it is an open architecture and can accept Dynamic Link Libraries of third parties. A natural extension of the work reported in this paper is to use this feature to interface with commercially available digital “relays”. The word “relay” is in quotation marks to indicate that the relay is simply a digital program that takes inputs of voltages and currents, performs an analysis of this data, applies logic and issues a decision. This program is an object and can be converted into a Dynamic Link Library. If this DLL is “linked” with the virtual power system, in the sense that the inputs come from the virtual power system, then the specific relay can be evaluated within the virtual environment. The technology for this approach is presently available. Yet, our experience is that relay manufacturers are not presently perceptive in making their “relay” objects available as DLLs that can be interfaced with third party software.

### Applications

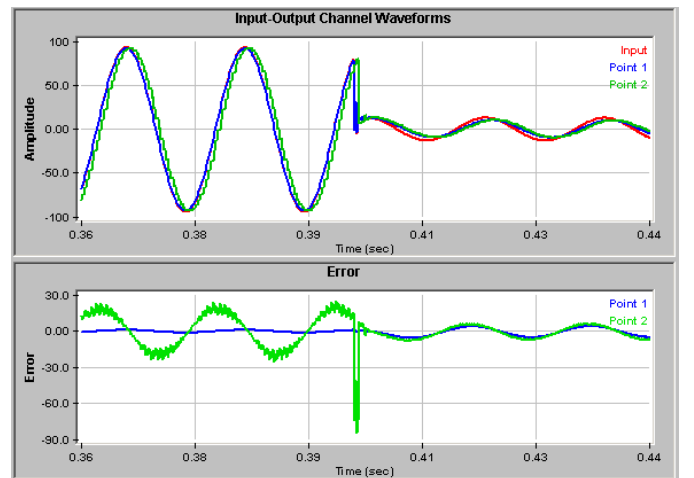
The described virtual environment has been used in a variety of educational assignments. The possible uses are only limited by the imagination of the educator. In this section we describe a small number of educational application examples.

**Application Example 1: Study of Instrumentation Channel Error:** Figures 3 and 4 illustrate an exercise of studying instrumentation channel performance. Figure 3 illustrates an example integrated model of a simple power system and the model of an instrumentation channel (voltage). The instrumentation channel consists of a PT, a length of control cable, an attenuator, and an A/D converter (Figure 3 illustrates the icons of these components and their interconnection). Figure 4 illustrates two waveforms: the voltage of phase A of the power system when it experiencing a fault and the error of the instrumentation channel. The upper part of the figure illustrate the actual voltage of Phase A and the output of the instrumentation channel (multiplied by the nominal transformation ratio). The two traces are quite close. The lower part of the figure illustrates the error between the two waveforms of the upper part of the figure. The two curves illustrate the normalized error at the input of the A/D converter and at the output of the A/D converter. The figure is self explanatory and a substantial error occurs during the transient of the fault. When the transients subside, the error of the instrumentation channel is relatively small. The intention of this exercise is to study the effects of different

parameters of the instrumentation channel. For example, the students can change the length of the control cable and observe the impact on the error. Or in case of a current channel, they can observe the effects of CT saturation on the error of the instrumentation channel, etc.

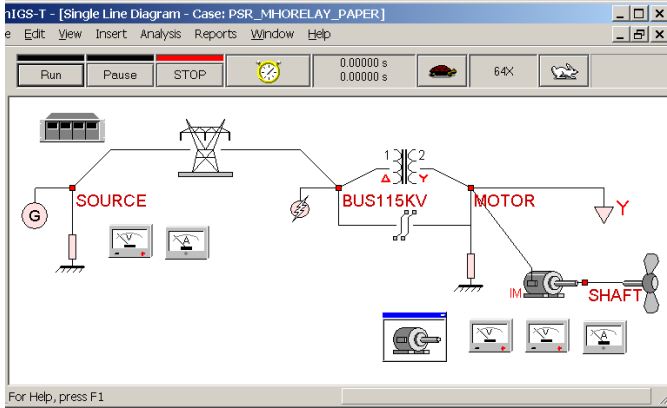


**Figure 3. Example Power System for Visualization and Animation of an Instrumentation Channel**

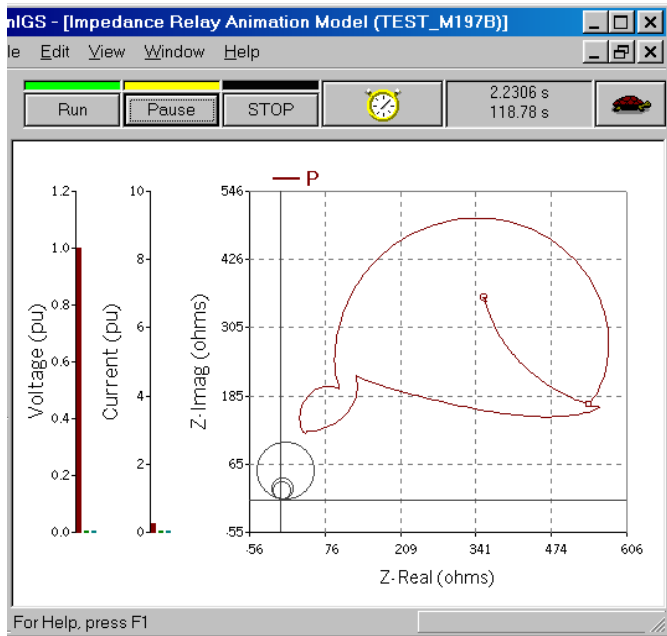


**Figure 4. Snapshot of the Channel Performance One Cycle Before and After the First Fault.**

**Application Example 2: Mho Relay:** Figure 5 illustrates the basics of an example application of the virtual power system for visualization and animation of a modified impedance relay. The example system consists of a generator, a transmission line, a step-down transformer, a passive electric load (constant impedance load), an induction motor and a mechanical load of the motor (fan). A modified distance relay (mho relay) monitors the transmission line. The operation of this relay is based on the apparent impedance that the relay ‘sees’ and the trajectory of this impedance.



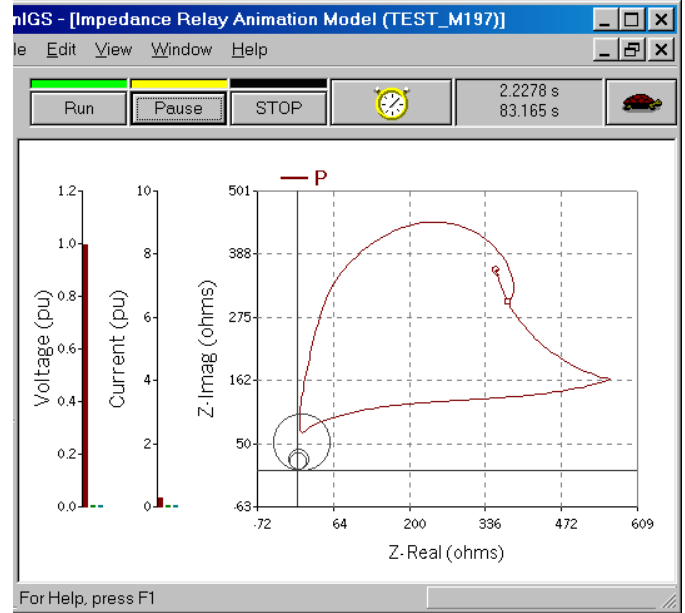
**Figure 5. Example Test System For Mho Relay Animation**



**Figure 6. Animation of a Modified Impedance Relay for a Single Line to Ground Fault on the 115 kV Bus**

The visualization object of this relay displays what the relay ‘sees’ during a disturbance in the system and superimposes this information on the relay settings. Typical examples are illustrated in Figures 6 and 7. The relay monitors the three phase voltages and currents at the point of its application. The animation model retrieves the information that the relay monitors from the simulator at each time step. Subsequently, it computes the phasors of the voltages and currents as well as the sequence components of these voltages and currents. Figure 6 illustrates a 2-D visualization of the operation of this relay over a period that encompasses a combined event of an induction motor start-up followed by a single phase fault on the high voltage side of the transformer. (This example demonstrates the flexibility of the tool to generate composite

events that may lead to very interesting responses of the protective relays). The left-hand side of the 2-D visualization shows the voltages and currents “seen” by the relay (the snapshot is after the fault has been cleared). The graph also shows the trajectory (history) of the impedance “seen” by the relay. The graph shows the trajectory “seen” over a user specified time interval preceding present time. The impedance trajectory is superimposed on the trip characteristics of this relay. In this case the impedance trajectory does not visit the trip “region” of the relay.



**Figure 7. Animation of a Mho Relay for a Three Phase Fault on the 13.8 kV Bus**

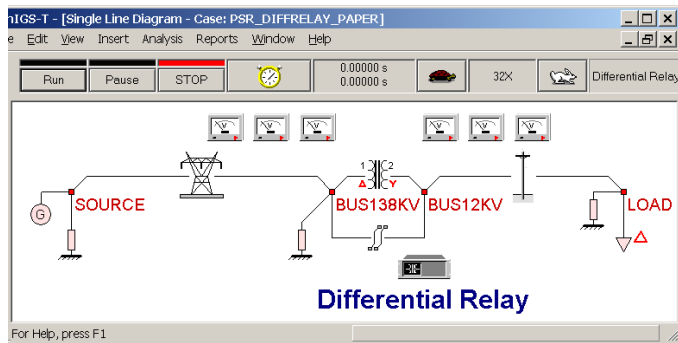
Figure 7 provides the recorded impedance trajectory for the combined event of an induction motor start-up followed by a three-phase fault near the low voltage bus of the transformer. The impedance trajectory is superimposed on the trip characteristics of this relay. In this case the impedance trajectory does visit the trip “region” of the relay.

This example can be extended to more advanced topics. For example, the animated display may also include stability limits for the “swing” of the generator. For this purpose the stability limits for the particular condition must be computed and displayed. This exercise can be the topic of a term project.

**Application Example 3: Differential Relay:** Another important protective relaying example is the differential relay. In this example we present the animated operation of a differential relay scheme for a delta-wye connected transformer with tap changing under load. The example system is shown in Figure 8. It consists of an equivalent source, a transmission line, a 30 MVA delta-wye connected transformer, a distribution line and an electric load. A

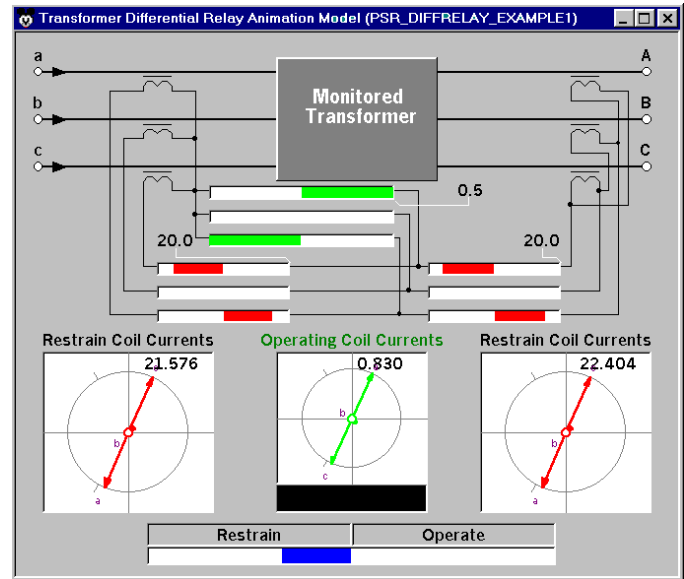
transformer differential relay is protecting the transformer. The differential relay has as inputs the transformer terminal currents. A specific implementation of a differential relay visualization is shown in Figure 9 based on the electromechanical equivalent relay. Note that the 2-D visualization shows the “operating” coils and “restraining” coils and the currents that flow in these coils at any instant of time. Instantaneous values, rms values and phasor displays are displayed.

and in very short time with the aid of animation and visualization methods.



**Figure 8. Example Test System For Transformer Differential Relay Animation**

Figure 9 illustrates one snapshot of the system. In reality, as the system operation progresses, this figure is continuously updated providing an animation effect. The system may operate under steady state or under transient conditions. The effects of tap changing on the operation of the relay are demonstrated. The importance of this animation module is that one can study the effects of various parameters and phenomena on the operation of the relay. Examples are: (a) effects of tap setting. The differential relay settings are typically selected for the nominal tap setting. As the tap setting changes under load, the current in the operating coil changes and may be nonzero even under normal operating conditions. It is very easy to change the tap setting and observe the operation of the relay in an animated fashion. It is also easy to observe the operation of the relay during a through fault for different values of tap settings. Thus this tool is very useful in determining the optimal level of percent restraint for the relay. (b) effects of inrush currents. One can perform energization simulations of the transformer by various types of breaker closing schemes. Since the transformer model includes the nonlinear magnetization model of the transformer core, the magnetization inrush currents will appear in the terminals of the transformer and therefore in the differential relay. The display of Figure 9, provides a full picture of the evolution of the electric currents. One can study the effects of inrush currents by bypassing the even harmonic filters as well as by implementing a number of harmonic filters and observing the effectiveness of the filters. It is important to note that the phenomena involved are very complex, yet a student can study these phenomena in depth



**Figure 9. Animation of a Transformer Differential Relay for a Single Phase to Ground Fault on the 115 kV Bus**

**Application Example 4: Testing of Physical Relays.** The virtual power system has been also used for testing of physical relays. This application is quite simple. The virtual power system has the capability to export voltage and current waveforms of any event and for any user selected time period in COMTRADE format. Then the COMTRADE file is fed into commercial equipment that generates the actual voltages and currents and feed them into the physical relays. The actual response of the relays is then observed. This application was performed on the premises of a utility with limited access to students. Recently, a major relay manufacturer (SEL) has donated equipment to Georgia Tech and we are in the process of setting up the laboratory for routine use of this function by students.

There are numerous other applications of the proposed virtual power system. The pedagogical objective is to instill a deep understanding of protective relaying concepts and problems in the very short time of one semester. The effectiveness of the proposed approach increases as new examples are generated and stored in the data base. A classical example that demonstrates the effectiveness of the virtual power system is the issue of sympathetic tripping. Usually, this topic requires several lectures and long examples. With the virtual power system, one can very thoroughly teach the concept of sympathetic tripping within one lecture. For example, a simple system with mutually coupled lines can be prepared, with relays at the ends of all lines. Then with a fault in one line, the relays of the healthy line can be visualized and

animated. The students can observe that the relays of the healthy line “see” zero sequence current induced by the fault on another line. And more important, they can make changes to the designs of the lines and observe the relative effect of design parameters on induced voltages and currents, etc.

## Conclusions

This paper has discussed and presented the virtual power system and its application for visualization and animation of protective relaying. The virtual power system has proved to be a valuable tool in the instruction of protective relaying courses. It is also an excellent tool for assigning term projects on various aspects of protective relaying. One important feature of the tool is that the user can apply disturbances to the system while the system operates, i.e. faults, load shedding, motor start-up, etc. The response of the relays is instantaneously observed. The paper has described the mathematical modeling required to achieve this feature in a multitasking environment. The paper has also discussed three generic protective relay exercises using the virtual power system: (a) visualization and animation of instrumentation channel error, (b) impedance relay and (c) a transformer differential relay. From these examples, it is clear that virtual laboratories can be quite beneficial from the educational point of view as they can provide insight of the system under study that are impossible in a physical laboratory. In addition, the virtual power system is valuable for testing commercially available digital relays with appropriate interfaces between the virtual power system and the numerical relay software.

The effectiveness of this approach has been assessed informally with discussions with students and evaluation of the term projects. The response is positive and enthusiastic (for example, two of the term project reports were over 100 pages long and the content reflected an excellent understanding of protective relaying concepts and technology). We plan to conduct formal evaluation of the approach by the students.

The tool is continuously under development as additional relay functions and animation and visualization objects of various protective relay functions are being developed. This task is open ended because of the plethora of existing power system relaying devices and possible ways to visualize and animate their functions. There is also a multiplicity of term projects that can be designed and assigned to students with the virtual power system as the basic tool. We also plan to make this tool available to power educators. Presently, the tool is posted on the course web site, when the course is offered. The web site is terminated when the course is completed. In the next offering of the course, the web site will be made permanent and accessible to power educators.

## Acknowledgments

The work reported in this paper has been partially supported by the ONR Grant No. N00014-00-1-0368. This support is gratefully acknowledged.

## References

1. A. P. Sakis Meliopoulos and G. J. Cokkinides, ‘A Time Domain Model for Flicker Analysis’, *Proceedings of the IPST '97*, pp. 365-368, Seattle, WA, June 1997.
2. A. P. Sakis Meliopoulos and George J. Cokkinides, ‘Virtual Power System Laboratories: Is the Technology Ready?’, *Proceedings of the 2000 IEEE/PES Summer Meeting*, Seattle, WA, July 16-20, 2000.
3. A. P. Sakis Meliopoulos, *Power System Grounding and Transients*, Marcel Dekker, Inc., 1988.
4. A. P. Sakis Meliopoulos, David Taylor, George J. Cokkinides and Ben Beker ‘Small Signal Stability Analysis in PEBB Based Systems’, *Proceedings of the 3rd International Conference on Digital Power System Simulators*, Vasteras, Sweden, May 25-28, 1999.
5. A. P. Meliopoulos and George J. Cokkinides ‘Small Signal Stability Analysis in PEBB Driven Motion Systems’, *Proceedings of the ELECTROMOTION '99 Symposium*, pp. 273-278, Patras, Greece, July 8-9, 1999.
6. A. P. Sakis Meliopoulos, George J. Cokkinides, B. Beker, and R. Dougal, ‘A New Tool for Visualization and Animation of Power Component and System Operation’, *Proceedings of the 33<sup>rd</sup> Annual Hawaii International Conference on System Sciences*, p. 95 (pp. 1-7), Wailea, Maui, Hawaii, January 4-7, 2000.
7. A. P. Sakis Meliopoulos, George J. Cokkinides and Jay Murphy, ‘Use of DFR Data for Fault Locating’, *Proceedings of the 2000 Georgia Tech Fault and Disturbance Analysis Conference*, Atlanta, Georgia, May 1-2, 2000.
8. A. P. Sakis Meliopoulos and George J. Cokkinides, ‘A Virtual Environment for Protective Relaying Evaluation and Testing’, *Proceedings of the 34<sup>th</sup> Annual Hawaii International Conference on System Sciences*, p. 44 (pp. 1-6), Wailea, Maui, Hawaii, January 3-6, 2001.
9. W. Gao, E. Solodovnik, R. Dougal, G. Cokkinides and A. P. Meliopoulos, ‘Elimination of Numerical Oscillations in Power System Dynamic Simulation’, *Proceedings of APEC 2003*, pp. xx-xx, Miami, FL, Feb 9-13, 2003.
10. A. P. Sakis Meliopoulos and George J. Cokkinides, Classnotes for ECE6323, *Power System Relaying: An Introduction*, Georgia Institute of Technology.
11. Stanley H. Horowitz and Arun G. Phadke, *Power System Relaying*, Research Study Press LTD, Second Edition, 2000.
12. J. L. Blackburn, *Protective Relaying: Principles and Applications*, Marcel Dekker, Inc, 1998.

## Biographies



**A. P. Sakis Meliopoulos** (M '76, SM '83, F '93) was born in Katerini, Greece, in 1949. He received the M.E. and E.E. diploma from the National Technical University of Athens, Greece, in 1972; the M.S.E.E. and Ph.D. degrees from the Georgia Institute of Technology in 1974 and 1976, respectively. In 1971, he worked for Western Electric in Atlanta, Georgia. In 1976, he joined the Faculty of Electrical Engineering, Georgia Institute of Technology, where he is presently a professor. He is active in teaching and research in the general areas of modeling, analysis, and control of power systems. He has made significant contributions to power system grounding, harmonics, and reliability assessment of power systems. He is the author of the books, *Power Systems Grounding and Transients*, Marcel Dekker, June 1988,

*Lighning and Overvoltage Protection*, Section 27, Standard Handbook for Electrical Engineers, McGraw Hill, 1993. He holds three patents and he has published over 180 technical papers. Dr. Meliopoulos is the Chairman of the Georgia Tech Protective Relaying Conference, a Fellow of the IEEE and a member of Sigma Xi.



**George Cokkinides** (M '85) was born in Athens, Greece, in 1955. He obtained the B.S., M.S., and Ph.D. degrees at the Georgia Institute of Technology in 1978, 1980, and 1985, respectively. From 1983 to 1985, he was a research engineer at the Georgia Tech Research Institute. Since 1985, he has been with the University of South Carolina where he is presently an Associate Professor of Electrical Engineering. His research interests include power system modeling and simulation, power electronics applications, power system harmonics, and measurement instrumentation. Dr. Cokkinides is a member of the IEEE/PES.