

COMPUTATION OF CRITICAL VALUES OF PARAMETERS IN POWER SYSTEMS USING TRAJECTORY SENSITIVITIES

Tony B. Nguyen, M. A. Pai, and I. A. Hiskens
Department of Electrical and Computer Engineering
University of Illinois at Urbana-Champaign
1406 West Green Street
Urbana, IL 61068, USA

Abstract - It has been known in the literature that system sensitivity increases sharply as the trajectory approaches the boundary of the region of attraction (ROA) while the trajectory does not exhibit such a sharp behavior. The relationship between sensitivity and stability of a nonlinear dynamic system such as the power system is investigated in this paper. In this context the role of the principal singular surface (PSS) also becomes significant. The principal singular surface is defined as a set of points enclosing the origin and where the Jacobian of the system evaluated at these points is singular. As the trajectory evolves, the Jacobian of the flow becomes singular at a point on the PSS and a sharp increase in trajectory sensitivity is observed. The mode of instability (MOI) can thus be defined very early during a faulted trajectory in most cases. A technique is also proposed using the norm of trajectory sensitivity vector at two points and then extrapolating it to estimate the critical parameter of interest which may be clearing time, mechanical power, etc.

Keywords: trajectory sensitivities, power system stability, principal singular surface

1 INTRODUCTION

Trajectory sensitivities have been used widely in adaptive control, parameter identification, etc. [1,2]. Its application to different aspects of power system stability is relatively new [3, 4]. Its main advantage is that it can handle any order of complexity in terms of modeling, such as differential-algebraic equations (DAE), discrete events coupled to DAE models, and hybrid systems as well [5]. In power systems when incorporating relay dynamics or tap changing transformer models, we get a DAE model with discrete events. Trajectory sensitivity becomes a useful tool since conventional stability analysis tools are inapplicable. In this paper we restrict to power systems represented by a system of differential equations (DE) only.

The concept of principal singular surface (PSS) was first introduced in [6] to assess the equilibrium analysis of power systems using classical model of the synchronous machine. In [7] the intersection of the PSS and the faulted trajectory was used to define a search direction for the starting point of a minimization process to compute the controlling u.e.p using the Davidon-Fletcher-Powell method. The PSS is the inflexion point in the potential energy plot and the Jacobian is the Hessian of the potential energy function. Thus the PSS is a function of only machine angles and

the network parameters. As the trajectory crosses the PSS, and if the system is stable, the eigenvalue will cross the imaginary axis again to come back to the left half plane, and the sensitivity will decrease. This process may be repeated for a number of times before the system eventually comes to the steady state. When the trajectory crosses the PSS, the machines with high sensitivities can be identified as the critical machines and thus the mode of instability (MOI) can be identified very early. If the system is unstable, the trajectory may cross the PSS before or after the ROA depending on system loading. In such a case the use of PSS has limited value. In the earlier literature, the MOI concept has been used in an intuitive manner while using the transient energy function technique successfully [8]. If the PSS crossing point is within the ROA, this point may give an early indication of the mode of instability (MOI).

In this paper we seek to explore the connection between sensitivity, PSS and ROA in a multi-machine context. Motivation through a single machine infinite bus (SMIB) system will be presented to illustrate the fact that depending on the system conditions, the crossing of ROA may occur before or after the PSS crossing. This depends on the loading of the generator in the SMIB system case and to the stressed nature of the system in the case of multi-machine system. The three-machine case is used to illustrate this point further.

A technique is proposed using the norm of trajectory sensitivity vector at two points and then extrapolating it to estimate the critical parameter of interest [9]. The critical parameters chosen are the generation power and clearing time of circuit breakers. This method will be validated on a 50-machine system.

2 THEORY

The m -machine classical model in relative rotor angle notation can be represented by a set of DE's as

$$\begin{aligned}\dot{\omega}_i &= (-D_i \omega_i + P_i - P_{ei}) / M_i = f_i(\alpha, \omega) \quad i=1,2,\dots, m \quad (1) \\ \dot{\alpha}_i &= \omega_i - \omega_m = f_{m+i}(\alpha, \omega) \quad i=1,2,\dots, m-1 \quad (2)\end{aligned}$$

where

$$\begin{aligned}\alpha_i &= \delta_i - \delta_m \\ P_i &= P_{Mi} - E_i^2 G_{ii} \\ \alpha_{ij} &= \alpha_i - \alpha_j\end{aligned}$$

$$P_{ei} = \begin{cases} \sum_{\substack{j=1 \\ j \neq i}}^{m-1} (C_{ij} \sin \alpha_{ij} + D_{ij} \cos \alpha_{ij}) \\ \quad + C_{im} \sin \alpha_i + D_{im} \cos \alpha_i & i \neq m \\ \sum_{j=1}^{m-1} (-C_{mj} \sin \alpha_j + D_{mj} \cos \alpha_j) & i = m \end{cases}$$

The notation is standard in the literature [8] and the m^{th} -machine is taken as the reference machine. The faulted and post-fault systems have the same structure except for different values of C_{ij} and D_{ij} .

Equations (1) and (2) are written in state space form as

$$\dot{x} = f(x, \lambda) \quad (3)$$

where $x = [x_1 \dots x_{2m-1}]^T = [\omega_1 \dots \omega_m \alpha_1 \dots \alpha_{m-1}]^T$ and λ is a parameter of interest such as mechanical input power, line reactance, clearing time, etc. In this paper we choose λ to be mechanical input power or the fault clearing time.

The sensitivity model is given as

$$\dot{x}_\lambda = f_x x_\lambda + f_\lambda, \quad x_\lambda(0) = 0 \quad (4)$$

where $x_\lambda = \frac{\partial x}{\partial \lambda}$, $f_x = \frac{\partial f}{\partial x}$, and $f_\lambda = \frac{\partial f}{\partial \lambda}$. Note that f_x and f_λ are time varying matrices and are evaluated along the trajectories. The entries of the Jacobian f_x are calculated as follows. For $i=1, \dots, m$; $j=1, \dots, m$; $k=1, \dots, m-1$; $n=1, \dots, m-1$

$$\frac{\partial f_i}{\partial x_j} = \begin{cases} -D_i / M_i & \text{if } i = j \\ 0 & \text{if } i \neq j \end{cases}$$

$$\frac{\partial f_i}{\partial x_{m+k}} = \begin{cases} -[\sum_{\substack{j=1 \\ j \neq i}}^{m-1} (C_{ij} \cos \alpha_{ij} - D_{ij} \sin \alpha_{ij}) + C_{im} \cos \alpha_i \\ \quad - D_{im} \sin \alpha_i] / M_i & \text{if } i = k, i \neq m \\ [C_{ik} \cos \alpha_{ik} - D_{ik} \sin \alpha_{ik}] / M_i & \text{if } i \neq k, i \neq m \\ -[-C_{ik} \cos \alpha_{ik} - D_{ik} \sin \alpha_{ik}] / M_i & \text{if } i = m \end{cases}$$

$$\frac{\partial f_{m+k}}{\partial x_j} = \begin{cases} 1 & \text{if } j = k, j \neq m \\ 0 & \text{if } j \neq k, j \neq m \\ -1 & \text{if } j = m \end{cases}$$

$$\frac{\partial f_{m+k}}{\partial x_{m+n}} = 0$$

Consider the Jacobian f_x of (3) in the region $-\pi < \alpha_i < \pi$. One can define the principal singular surface for both the faulted and post-fault systems. But

for a large system there is not much difference between the two. In the special case for the SMIB system, both the faulted and post-fault systems have the same PSS, namely, the lines corresponding to $\pm\pi/2$. Hence, we consider only the PSS of the post-fault system in this paper. As the trajectories evolve with time, the Jacobian becomes singular at a point where one or more eigenvalues cross the imaginary axis. At the crossing of the PSS the rotor angles with high sensitivities are the machines likely to go unstable. The group of machines corresponding to highest sensitivities at the exit point will become unstable ultimately if the fault was sustained longer than the critical clearing time. Thus we develop an early test for detecting the MOI.

3 SMIB SYSTEM

A single machine infinite bus (SMIB) system (Fig. 1) is used to illustrate the concepts of PSS and sensitivity phase plane behavior. The three phase fault is assumed to occur at the terminal of the machine at $t = 0$ and cleared at $t = t_{cl}$.

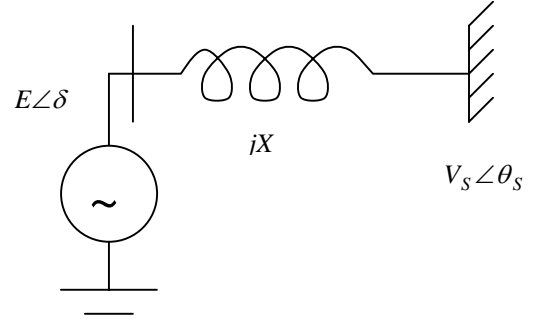

Figure 1: Single machine infinite bus-system.

The system can be described by the swing model as

$$\begin{aligned} M\ddot{\delta} + D\dot{\delta} &= P_M & 0 < t \leq t_{cl} \\ M\ddot{\delta} + D\dot{\delta} &= P_M - P_{em} \sin \delta & t > t_{cl} \end{aligned} \quad (5)$$

The corresponding sensitivity model is

$$\begin{aligned} M\ddot{u} + D\dot{u} &= 1 & 0 < t \leq t_{cl} \\ M\ddot{u} + D\dot{u} &= 1 - (P_{em} \cos \delta)u & t > t_{cl} \end{aligned} \quad (6)$$

where the parameter λ in this case is chosen as P_M ,

and $u = \frac{\partial \delta}{\partial P_M}$ is the sensitivity of rotor angle with

respect to mechanical input power. One can choose any other parameter such as line reactance, damping coefficient, fault clearing time, etc.

Depending on the value of mechanical input power and t_{cl} , the PSS crossing point can be reached before or after the ROA crossing. For the low value of P_M , the faulted trajectory will cross the PSS before it crosses the ROA as shown in Fig. 2. The clearing time may be before or after crossing the PSS. On the other hand, for

a high value of P_M the faulted trajectory will cross the ROA before it crosses the PSS even for a lower value of t_{cl} as shown in Fig. 3. The critical value of P_M at which the crossing of PSS occurs before ROA is derived in the appendix. This value satisfies the inequality $P_M < 0.3942P_{em}$ (Fig. 2).

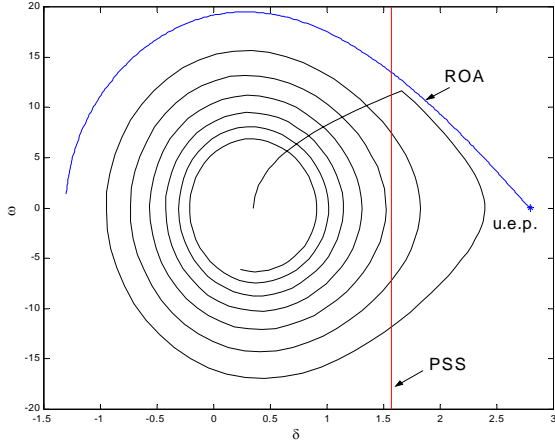

Figure 2: PSS crossing before ROA (low value of P_M), $t_{cl} = 0.224$ s.

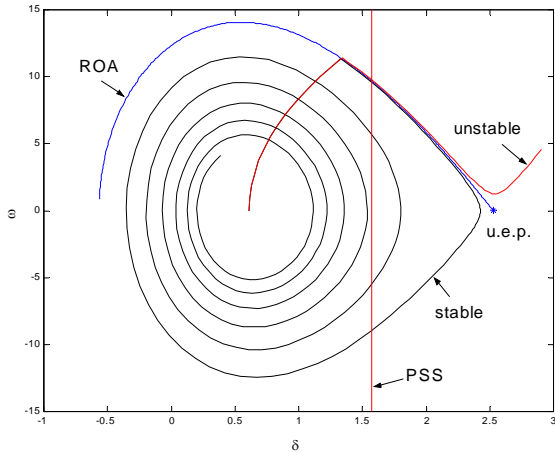

Figure 3: PSS crossing after ROA (high value of P_M), $t_{cl} = 0.126$ s.

4 THREE-MACHINE SYSTEM

In this section we extend the concepts of SMIB system to a 3-machine system case. Fig. 4 shows the result for the nominal loading case and the system is stable. In this case the PSS crossing occurs before the ROA crossing. The '+' sign indicates the fault clearing instant. The u.e.p. in this case is also shown in Fig. 4 and its value is $(\alpha_1, \alpha_2) = (1.4033, 3.2035)$. Fig. 5 shows the result for the unstable case where the system loading is increased by 40% of the nominal case. In this case the PSS crossing occurs after the ROA crossing. The u.e.p. in this case is $(\alpha_1, \alpha_2) = (1.7333, 2.9698)$. From Fig. 5 one can

observe that the machines associated with $\alpha_1 = \delta_1 - \delta_3$ and $\alpha_2 = \delta_2 - \delta_3$ are the critical machines.

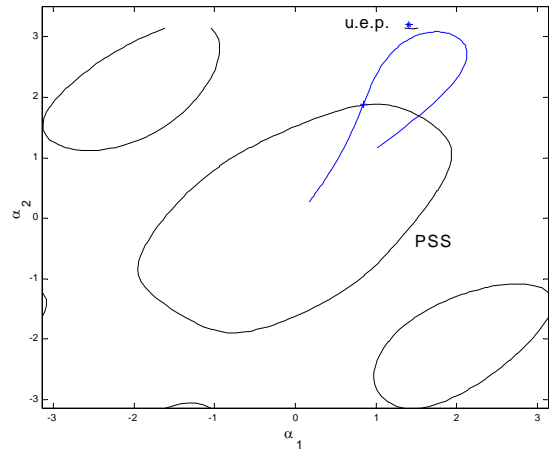

Figure 4: The PSS crossing occurs before the ROA crossing (nominal case).

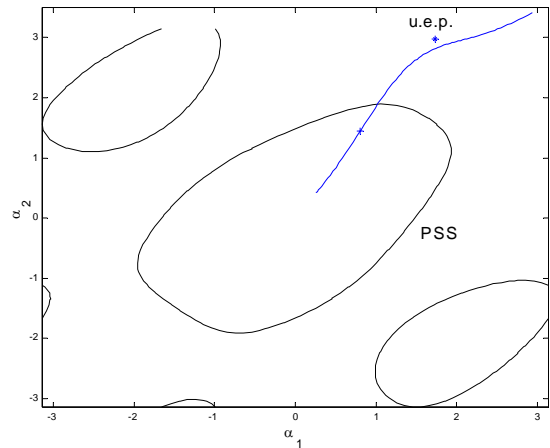

Figure 5: The PSS crossing occurs after the ROA crossing (increased system loading case).

5 PROCEDURE TO DETECT THE MOI

A procedure is proposed to detect the MOI based on sensitivities at the PSS crossing point assuming that the PSS is crossed before the ROA is crossed. For a given fault we generate the trajectory sensitivities of the rotor angles with respect to the mechanical input powers.

This will be the $(m-1) \times (m-1)$ matrix $S = \left[\frac{\partial \alpha_i}{\partial P_{Mj}} \right]$, i, j

$= 1, \dots, m-1$. Sensitivity of the rotor angle is generally high with respect to its own mechanical input power. Thus it is sufficient to examine only the diagonal terms of the sensitivity matrix. By examining the sensitivities we can identify the machines likely to go unstable, i.e., the group of machines with high sensitivities at the PSS crossing point. The procedure is illustrated with the 50-

machine system [8]. A self-clearing fault is simulated at bus 66 and cleared at $t_{cl} = 0.15$ s. The system is stable, and the diagonal terms of the sensitivity matrix S are calculated and shown in Fig. 6. From this figure it can be verified that the group of machines with high sensitivities will likely go unstable if the fault is not cleared soon enough. These machines are 1-22, 24-27, and 33-35. Although the entire time domain simulation is given, it is sufficient to examine the sensitivities at the PSS crossing (marked with + sign) in Fig. 6. Examination of numerical values of sensitivities at the PSS crossing does not show a clear break between the critical machines and the rest of the machines. At the same time the trend for the machines with high sensitivities to go unstable is always displayed. This is verified by simulation with t_{cl} slightly greater than t_{cr} as shown in Fig. 7.

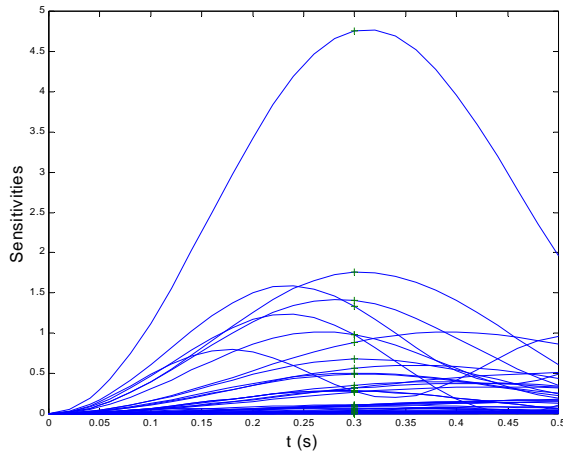

Figure 6: Sensitivities of relative rotor angles ($t_{cl} = 0.15$ s).

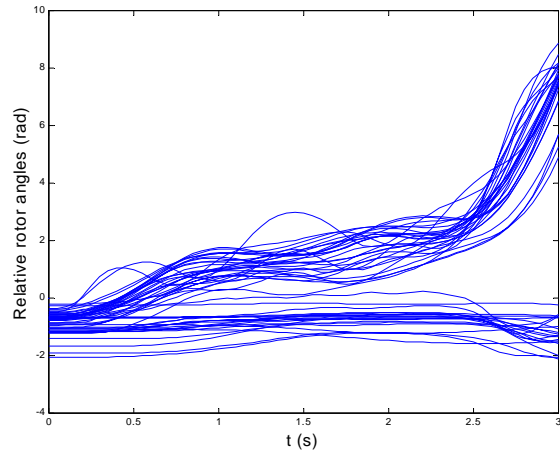

Figure 7: Relative rotor angles with t_{cl} slightly greater than $t_{cr} = 0.166$ s.

6 CRITICAL PARAMETER COMPUTATION USING SENSITIVITIES

In this section we propose a technique to compute the estimated value of critical parameter. The technique

involves computation of sensitivity at two values of the parameter and then extrapolating to obtain an estimate of the critical values. This idea is similar to that of [10] where the critical value of a parameter is estimated using an extrapolation technique.

6.1 Computation of critical clearing time

One possible measure of proximity to instability is through some norm of the sensitivity vector. We propose the Euclidean norm of the sensitivity vector. We associate with each value of t_{cl} the maximum value of the sensitivity norm along the trajectory. The procedure to calculate the estimated value of t_{cr} using the sensitivity norm is described as follows. The sensitivity norm is computed for two different values of t_{cl} , which are chosen to be less than t_{cr} . Here, the sensitivity norm for an m -machine system is defined as

$$\mathbb{R} = \sqrt{\sum_{i=1}^{m-1} \left(\frac{\partial \alpha_i}{\partial t_{cl}} \right)^2 + \sum_{i=1}^m \left(\frac{\partial \omega_i}{\partial t_{cl}} \right)^2}$$

The plot of \mathbb{R} for the 50-machine system when $t_{cl} = 0.28$ s is shown in Fig. 8.

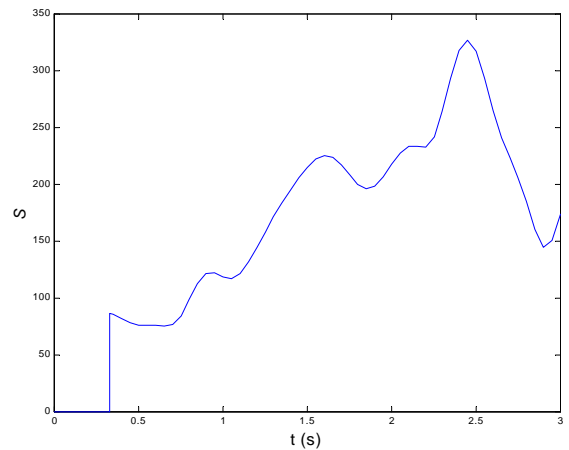

Figure 8: The plot of \mathbb{R} vs. time for $t_{cl} = 0.28$ s.

The reciprocal of the maximum of \mathbb{R} is calculated for each value of t_{cl} , $\eta = 1/\max(\mathbb{R})$. A straight line is then constructed through the two points (t_{cl1}, η_1) and (t_{cl2}, η_2) . The estimated critical clearing time $t_{cr,est}$ is the intersection of the constructed straight line with the time-axis in the (t_{cl}, η) -plane as shown in Fig. 9.

The measure η is approximately linear only in the region near t_{cr} where the sensitivities grow very quickly as t_{cl} increases. Therefore, if the two points are taken far away from t_{cr} , the extrapolation will not give accurate results. Based on experience one can choose the two values of t_{cl} near t_{cr} .

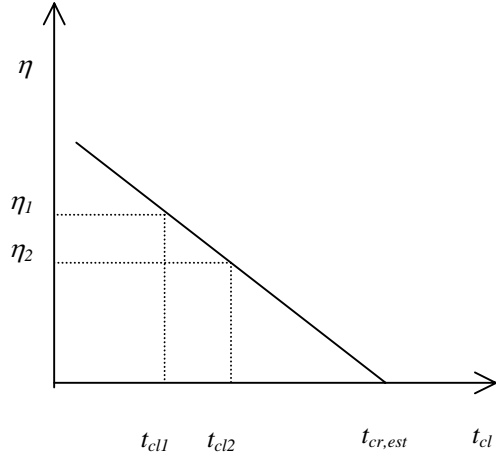

Figure 9: Estimate of t_{cr} .

The proposed technique was applied to the 50-machine system to estimate the critical clearing time for the self-clearing fault at bus 58. For illustrative purposes the result is shown in Fig. 10. The actual clearing time is $t_{cl} = 0.315$ s. If the two values of t_{cl} are chosen in the close range of t_{cr} , the estimated value of t_{cr} will be quite accurate. As seen from Fig. 10, picking arbitrary values of t_{cl} may give erroneous results. Since computing sensitivities is computational extensive, choosing good values of t_{cl} requires judgment and experience.

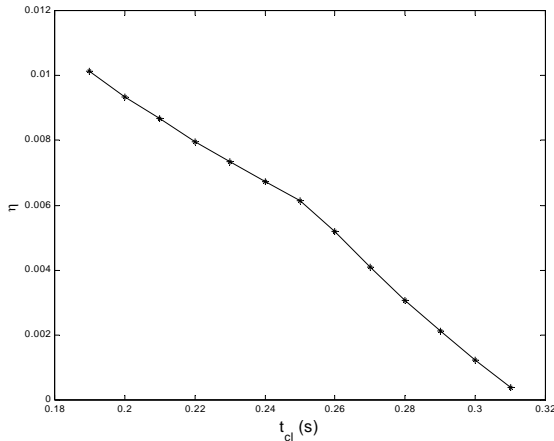

Figure 10: Estimate of t_{cr} for 50-machine system.

6.2 Computation of critical loading of generator (parameter P_M)

The sensitivity norm technique is used in this section to estimate the critical value of generator loading, or equivalently, the mechanical input power P_M . As in the case of t_{cl} , simulations for two values of P_M are carried out. The change in P_M is distributed uniformly among all loads in the system, so that the loading of the rest of the generators is unchanged. Conversely, if the system load increases uniformly, it is assumed to be taken up by this generator. The sensitivity norm is calculated for

the two specified values of P_M and then extrapolated to obtain the estimated critical value of P_M for the chosen generator. The 50-machine system was used as a numerical example in applying the technique to estimate the critical input power for several machines in the system. The self-clearing fault is simulated at bus 58 and cleared at $t_{cl} = 0.15$ s. The result is shown in Table 1.

Machine Number	$P_{M,est}$ (pu)	$P_{M,act}$ (pu)
4	22.9	22.3
5	17.0	16.5
7	4.3	4.2
12	10.0	9.6

Table 1: Estimate of critical input power.

7 CONCLUSION

The trajectory sensitivity at the PSS crossing of multi-machine power systems is used to detect the MOI in most cases. The relationship between trajectory sensitivity, PSS, and MOI has been explored. A method is proposed to estimate critical value of fault clearing time and mechanical input power using norm of the sensitivities at two points. The use of PSS crossing to detect MOI requires that the PSS crossing occurs before the crossing of ROA. Nevertheless, for systems satisfying that requirement, the proposed procedure provides a quick tool to detect the MOI.

REFERENCES

- [1] R. Tomovic, *Sensitivity Analysis of Dynamic Systems*. McGraw-Hill Book Company, 1963.
- [2] P. M. Frank, *Introduction to System Sensitivity Theory*. New York: Academic Press, 1978.
- [3] M. J. Laufenberg and M. A. Pai, "A new approach to dynamic security assessment using trajectory sensitivities," *IEEE Transactions on Power Systems*, vol. 13, no. 3, pp. 953-958, August 1998.
- [4] I. A. Hiskens and M. Akke, "Analysis of the Nordel power grid disturbance of January 1, 1997 using trajectory sensitivities," *IEEE Transactions on Power Systems*, vol. 14, no. 3, pp. 987-994, Aug. 1999.
- [5] I. A. Hiskens and M. A. Pai, "Trajectory sensitivity analysis of hybrid systems," *IEEE Transactions on Circuits and Systems Part I: Fundamental Theory and Applications*, vol. 47, no. 2, pp. 204-220, Feb. 2000.
- [6] C. J. Tavora and O. J. M. Smith, "Equilibrium analysis of power systems," *IEEE Transactions on Power Apparatus and Systems*, vol. PAS-91, no. 3, pp. 1131-1137, May-June 1972.
- [7] T. Athay, R. Podmore, and S. Virmani, "A practical method for direct analysis of transient

stability,” *IEEE Transactions on Power Apparatus and Systems*, vol. PAS-98, no. 2, pp. 573-584, March-April 1979.

- [8] A. A. Fouad and V. Vittal, *Power System Transient Stability Analysis Using the Transient Energy Function Method*. New Jersey: Prentice-Hall, Englewood Cliffs, 1991.
- [9] T. B. Nguyen, M. A. Pai, and I. A. Hiskens, “Sensitivity approaches for direct computation of critical parameters in a power system,” *International Journal of Electrical Power and Energy Systems*, to appear.
- [10] M. Pavella, D. Ernst, and D. Ruiz-Vega, *Transient Stability of Power Systems: A Unified Approach to Assessment and Control*. Boston: Kluwer Academic Publishers, 2000.

APPENDIX

For the SMIB system described by (5), the system stability can be assessed by using the equal area criterion. The following quantities are defined for power-angle curve of Fig. 11.

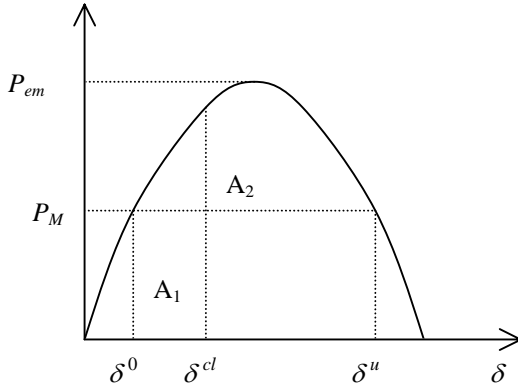

Figure 11: Power angle curve of the post fault system.

δ^0 : the s.e.p.

$\delta^u = \pi - \delta^0$: the u.e.p.

δ^{cl} : the rotor angle at the clearing time.

$$A_1 = P_M (\delta^{cl} - \delta^0)$$

$$A_2 = \int_{\delta^{cl}}^{\pi - \delta^0} (P_{em} \sin \delta - P_M) d\delta$$

$$= P_{em} (\cos \delta^0 + \cos \delta^{cl}) - P_M (\pi - \delta^0 - \delta^{cl})$$

The system is stable if the accelerating area (A_1) is smaller than the decelerating area (A_2) or

$$P_M (\delta^{cl} - \delta^0) < P_{em} (\cos \delta^0 + \cos \delta^{cl}) - P_M (\pi - \delta^0 - \delta^{cl}) \quad (\text{A.1})$$

We seek to find the maximum value of P_M such that for a fault cleared at $\delta^{cl} = \pi/2$ corresponding to the PSS, the trajectory is still inside the ROA. For this we substitute $\delta^{cl} = \pi/2$ into (A.1). This results in

$$P_M (\pi - 2\delta^0) < P_{em} \cos \delta^0 \quad (\text{A.2})$$

Substituting $\sin \delta^0 = P_M / P_{em}$ and $\cos \delta^0 = \sqrt{1 - (P_M / P_{em})^2}$ into (A.2) and rearranging yields

$$\frac{P_M}{P_{em}} \left(\pi - 2 \arcsin \frac{P_M}{P_{em}} \right) < \sqrt{1 - \left(\frac{P_M}{P_{em}} \right)^2} \quad (\text{A.3})$$

This inequality is satisfied when $\frac{P_M}{P_{em}} < 0.3942$ or

$P_M < 0.3942 P_{em}$. This is obtained by solving (A.3) for

$$\frac{P_M}{P_{em}}.$$