



Investigation of Fuel Cell System Performance and Operation: A Fuel Cell as a Practical Distributed Generator

Project Report

Power Systems Engineering Research Center

*A National Science Foundation
Industry/University Cooperative Research Center
since 1996*





Power Systems Engineering Research Center

**Investigation of Fuel Cell System Performance
and Operation: A Fuel Cell as a Practical
Distributed Generator**

George Karady, Project Leader
Priyantha Sirisooriya
Richard G. Farmer
Arizona State University

PSERC Publication 02-26

May 2002

Information about this Project

For information about this project contact:

George Karady
Arizona State University
Department of Electrical Engineering
P.O. Box 875706
Tempe, AZ 85287-5706
Phone: 480 965 6569
Fax: 480 965 0745
Email: karady@asu.edu

Power Systems Engineering Research Center

This is a project report from the Power Systems Engineering Research Center (PSERC). PSERC is a multi-university Center conducting research on challenges facing a restructuring electric power industry and educating the next generation of power engineers. More information about PSERC can be found at the Center's website: <http://www.pserc.wisc.edu>.

For additional information, contact:

Power Systems Engineering Research Center
Cornell University
428 Phillips Hall
Ithaca, New York 14853
Phone: 607-255-5601
Fax: 607-255-8871

Notice Concerning Copyright Material

Permission to copy without fee all or part of this publication is granted if appropriate attribution is given to this document as the source material. This report is available for downloading from the PSERC website.

© 2002 Arizona State University. All rights reserved.

Acknowledgements

The work described in this report was sponsored by the Power Systems Engineering Research Center (PSERC). We express our appreciation for the support provided by PSERC's industrial members and by the National Science Foundation under grant NSF EEC 0001880 received under the Industry/University Cooperative Research Center program.

This report is of work done under the PSERC project "Investigation of Fuel Cell Performance and Operation." This report is from the first year's work in a multi-year project with the Salt River Project. Their technical assistance in preparing this report is appreciated.

Executive Summary

This is the initial report in a multi-year project entitled “Investigation of Fuel Cell System Performance and Operation.” The project is to study the system performance and operation of a fuel cell distributed generator and to provide an assessment of the electrical, thermal, and economic issues associated with the fuel cell system. This report provides an introduction to technical and thermal performance of fuel cells in general, and to the Phosphoric Acid Fuel Cell installed in the City of Mesa, Arizona in particular. It also describes an economic analysis of a fuel investment decision from the end-user’s perspective. Future project work will look more broadly at issues associated with integrating fuel cells as a form of distributed generation in the distribution network.

This report is based on completion of the following project tasks:

1. Completed a literature survey on fuel cell performance and operation as a distributed generator.
2. Collected performance and operational data from the Phosphoric Acid Fuel Cell installed at City of Mesa.

Set up the arrangement to remotely access the data acquisition system of the fuel cell and to continuously download data to a computer at Arizona State University.

3. Analyzed collected data to calculate fuel cell performance parameters

Calculated such performance parameters as Heat Rate, Electrical Efficiency, Overall Efficiency, Capacity Factor, Availability and Fuel/Operational and Maintenance Costs for the fuel cell. (see Sections 1.3 and 3.1) The performance parameters are being continuously recalculated and updated as and when new operational data are available.

4. Developed an economic model to assess the economic feasibility of fuel cells as distributed generators and implemented the fuel cell economic model in an interactive spreadsheet.

The economic model outputs the economic measures for the fuel cell based on the data entered as inputs to the model. The model will output the cash flows and calculate the payback period, net present value (NPV), internal rate of return (IRR), based on which, one could analyze the economic feasibility of the fuel cell. (see Section 4.0)

5. Studied the fuel cell heat recovery methods adopted at City of Mesa installation and submitted a supplementary report on the thermal heat recovery of the fuel cell.

Table of Contents

<u>Section</u>	<u>Page</u>
1.0 Introduction	1
2.0 Literature Summary	4
2.1 Introduction	
2.2 Thermodynamics and Chemical Operation	
2.3 Electrical Operation	
2.4 Economic Analysis	
3.0 Technical Performance	10
3.1 Performance Parameters	
3.2 Energy Balance	
3.3 Fuel Cell Stack Performance	
4.0 Thermal Performance	16
4.1 Thermal Performance	
4.2 Site Details	
4.3 Heat Recovery Systems	
4.4 Available Heat from the Fuel Cell	
4.5 Details of Thermal Equipment	
4.6 End Notes	
5.0 Economic Model	22
5.1 Introduction	
5.2 Modeling Techniques	
5.3 Spreadsheet Implementation	
5.4 Data Input	
5.5 Calculation Procedure	
5.6 Output Results and Economic Analysis	
5.7 End Notes	
6.0 Conclusion	34

Investigation of Fuel Cell System Performance and Operation: A Fuel Cell as a Practical Distributed Generator

1.0 Introduction

This is the initial report for the 'fuel cell performance evaluation project' undertaken by the College of Engineering, Arizona State University. The objective of the project is to investigate and characterize the performance and operation of a fuel cell in a commercial building environment and as applied to distributed generation. The overall project scope includes a study to characterize system performance and operation and to provide a preliminary assessment of the electrical, thermal, economic and environmental issues associated with the fuel cell system. This is a case study based on the installation of a fuel cell at the City of Mesa, Arizona.

A summary of the project tasks carried out to complete this report is given below. Further details of the respective tasks are included in subsequent sections.

Literature Summary

The first task was to study the literature on fuel cells, in order to ascertain the current status of fuel cells. The literature review included a study of the types of fuel cells available, their applications, limitations, future trends and development, the economic feasibility, and applicability as a distributed generator for utility. (see Section 2.0 for the literature summary)

Remote Data Acquisition

Remote data acquisition of the fuel cell (FC) system via a dial up link was set up in order to have measured operational data downloaded to a remote computer at Arizona State University (ASU). The required software and access to the data acquisition system were made available by City of Mesa after consulting the FC manufacturer. The remote data acquisition system enables down loading of certain important measured data from the FC at regular intervals.

Accessible data parameters include:

- Voltage, current and power measurements of the FC electrical output
- Voltage and current measurements of the FC dc stack output
- Cumulative load time and electrical energy output of the FC

Given below is a sample of downloaded data from the remote data acquisition (RADAR) system.

D_DATE	D_TIME	IDCNET	INV_IA	INV_IB	INV_IC	INV_IVAB	INV_IVBC	INV_IVCA	INV_VDC	KVARNET
1/16/2001	12:55:15	1454.735	269.5962	275.5726	270.6326	511.0547	515.625	512.2266	159.613	123.2583
1/16/2001	13:55:14	1456.448	268.8016	275.1926	270.0107	513.1641	517.3828	513.6328	159.6863	123.7881
1/16/2001	17:55:13	1426.773	272.2562	277.8872	273.6035	506.6016	511.1719	507.4219	160.2905	123.6216
1/16/2001	18:55:12	1457.986	267.9725	274.6744	269.1816	513.5156	519.4922	514.6875	160.0891	123.3643
1/16/2001	23:55:11	1453.668	269.2162	274.9854	270.0453	512.2266	516.5625	513.2813	159.7961	124.0908
1/17/2001	0:55:10	1450.047	269.5271	275.8835	270.4944	511.7578	515.8594	512.1094	159.906	124.4995
1/17/2001	5:55:08	1416.104	270.3217	276.5054	271.2544	509.6484	513.5156	510.2344	161.2427	123.7729
1/17/2001	6:55:08	1420.343	270.8398	276.989	272.118	508.5938	514.5703	509.4141	160.8948	123.8789
1/17/2001	12:38:57	1422.91	269.5962	275.9872	270.218	512.6953	516.0938	513.5156	161.0779	123.8638

An event history of the FC operation is also available and includes such data as plant down time and faulty signals. This information is used to calculate the reliability indices for the FC system.

Fuel Cell Technical Performance Study

Technical performance parameters for the fuel cell were calculated based on the downloaded data from the fuel cell, measured data, and estimated typical data for similar installations. The performance evaluation includes both electrical and thermal performance of the fuel cell. (see Sections 3.0 and 4.0)

A summary of the important calculated performance parameters is presented below.

Natural gas input	1,899	scfh
Net heat rate	10,073	Btu/kWh (for an HHV of 1030 btu/ft ³)
Electrical efficiency	33.9%	
Thermal heat available	880	Mbtu/h
Overall efficiency	79.9%	
Fuel cost	0.038	\$/kWh (for a Nat. Gas rate of 4.0 \$/Mcf)
	0.047	\$/kWh (for a Nat. Gas rate of 5.0 \$/Mcf)
	0.057	\$/kWh (for a Nat. Gas rate of 6.0 \$/Mcf)
Operational and maintenance cost	4.81	mills/kWh
Capacity Factor	87.4%	(for the period April 2000 to April 2001)
Availability	91.0%	(for the period April 2000 to April 2001)

Economic Model

Another consideration in the project was the evaluation of economics for the fuel cell. The approach, assumptions and calculations for an economic analysis would depend on the sector for which the model is targeted. The economic evaluations performed were primarily targeted for the building sector. The economic model would output the economic measures for the fuel cell based on the input data to the model. That is, the model will output the cash flows and calculate the payback period, net present value

(NPV), internal rate of return (IRR), based on which one could analyze the economic feasibility of the fuel cell. The spreadsheet implementation of the economic model is described in detail in Section 4.0.

Efficiencies and Energy/Mass Balance

A calculation procedure for the energy and mass balance for the fuel cell system was prepared after identifying different incoming and outgoing energy/mass sources of the system. Procedures and methods employed in standard energy audit practices were followed in determining the calculation and measuring procedures. The materials required for electrical energy components of the energy balance are already available through the remote data acquisition system (RADAR). Some of the actual thermal measurements required for associated thermal energy quantification for the energy and mass balance are not available. Additional thermal measurements required include measurements on fuel cell exhaust gas, makeup water, and incoming air. The required measurements and measuring techniques have been identified and an actual thermal measurement plan is to be discussed with City of Mesa.

2.0 Literature Summary

2.1 Introduction

With the progress that has been made in small-scale generator units, the concept of distributed generation has taken new dimensions in the power industry. Distributed generation deals with small power generation units being located near consumers and load centers providing benefits to customers and support for the economic operation of the existing power distribution unit. High efficient small-scale reciprocating engines and combustion turbines together with emerging technologies such as fuel cells, micro turbines, and photovoltaic provide a variety of options for distributed power generation [14].

The fuel cell (FC), an environmentally friendly and efficient source of alternative energy, is considered as a promising technology for distributed generation. Its ability to deliver power while contributing to cogeneration have added to its attractiveness as an electricity and heat source. Although, some types of fuel cells for distributed generation are commercially available, low cell durability in certain technologies and high manufacturing costs have retarded the pace of market entry in large proportions [2]. Fuel cell system performance, as applied to distributed generation, could be investigated under three major classifications: electrical operation, thermodynamics/chemical operation, and economic analysis. A complete fuel cell power plant has four basic subunits. Namely, fuel processing unit (reformer), air processing unit, FC stack, and the power conditioner unit [7]. The classification of fuel cell types is mainly based on the type of electrolyte used and relates to the thermodynamic/chemical operation of the fuel cell.

2.2 Thermodynamics and Chemical Operation

A fuel cell is defined as an electrochemical device in which energy stored in the chemical bonds of a conventional fuel is converted through the external circuit into low voltage, direct current (dc) electrical power. The basic components of this electrochemical cell comprise of an anode, which requires H₂ fuel, a cathode that brings O₂, and an electrolyte which provides for an ion exchange mechanism [9][16].

Individual fuel cells typically generate output voltages in the range of 0.7V to 0.8V. They are stacked in series to produce the required voltage at the total stack dc output [1]. Interconnection arrangements and design topologies are discussed in detail in [16].

Thermal Performance

Thermal performance evaluation of a Fuel Cell system is dependent on the type and make of fuel cell. Different manufacturers have different topologies and those specific design details may be required in assessing the performance. However, in a typical thermal

performance evaluation exercise, the following parameters and components may be identified and quantified [13][14].

Fuel/Natural Gas:

- Feed rate
- Low heat value
- Sulfur content

Water make-up:

- Feed rate

Stack:

- Current density
- Cell voltage
- Pressure
- Temperature
- Anode gas % (H₂/CO/CH₂/CO₂)
- Cathode gas % Air (O₂/N₂)

Design parametric equations in Fuel Cell Handbooks [16] can be used in calculations and evaluations.

Thermal efficiency of a Fuel Cell system is directly coupled with the electrical efficiency of the system. Overall efficiency may be given in terms of power output against fuel heat value. A net heat rate value (Btu/kWh) can be calculated for the system [13]. Cogeneration systems should be taken into account when calculating the overall efficiency. The basis of efficiency calculations should indicate whether higher heating value (HHV) or lower heating value (LHV) of the fuel was used for calculations. Also, it is important to note whether the efficiency figure is based on dc electrical output or ac output.

Following is another approach to represent efficiency summary [14].

Natural gas input	A	kW
Cell o/p	B	kW
Recovery	C	kW
Gross output	D=B+C	kW
Parasitic power	E	kW
Net output	F=D-E	kW
System efficiency	F/A	

A mass balance for the system could be done based on the quantified values of input and output components of the system. This should take into account the waste heat recovery provisions of the system as well. Emissions of the system are considered and quantified in the mass balance exercise. Energy balance also is an integral part of the mass balance and involves in quantifying the input and output energy (heat/electrical) values of different components of the system. Energy and mass balance are part of an energy audit and basic guidelines for an energy audit are discussed in [15].

2.3 Electrical Operation

The basic principles of electrical operation are similar for all the types and involve conversion of dc output of FC stacks into an ac source. The common electrical characteristic of the FC output is that the dc cell voltage, at lower current densities, drops significantly more than at higher current densities [1]. A power conditioner unit converts the dc output from the FC stack into a sinusoidal ac voltage and current which is suitable for domestic and industrial use.

Power Conditioner Unit (PCU)

Different topologies are proposed and used for the design of the PCU. In one of the approaches [1] a 600V IGBT module switched at 10 kHz is used for the inverter and to produce a 3-ph supply. A closed loop proportional integral (PI) is digitally implemented to maintain the output voltage at a particular set value regardless of the variation of the input voltage. For this inverter a Siemens microcontroller is used for the implementation of PWM waveform generation and the digital control of the power conditioning system. In another approach [7], for a prototype design, full bridge topology with MOSFETs has been used to implement inverter hardware and an Intel microcontroller has been used for the controller.

Generally, an inverter output current includes high harmonics. To avoid such harmonics, voltage waveform distortion in a power network should be held to less than a few percent. It is important to see that stipulated levels of harmonic contents are not exceeded. Other concerns with a PCU would be power losses, space required for installation, and stable continuous operation. The performance of a PCU may be analyzed under different conditions of operation such as how it would respond to a voltage dip caused by a short circuit fault in the power network. [6] The response of the PCU to sudden load changes may also be investigated to see whether the output voltage is affected. In addition, the response from dc output voltage variations of FC stack may also be analyzed. [1] For performance analysis of these kinds of devices, use of a “Transient Network Analyzer” (TNA) is suggested in [6].

PCU of a FC system generally should respond to stack output voltage reductions of more than 30% with changes in output current in the range 0~100%. The rated voltage of FC

stack decreases about 10% with increasing running time and this must also be taken into account. [6]

Electrical Efficiency

Although the theoretical electrical efficiency of a fuel cell is estimated to be greater than 70%, the current technology has only been capable of reaching efficiencies of around 45%. Combined cycle units increase this efficiency.

The power generating efficiency for phosphoric acid fuel cell (PAFC) plants are estimated to be in the range of 35-45%. The efficiency of a fuel cell is defined as percentage of electrical energy generated per hydrogen energy input. Generally cell efficiency increases with higher operating temperatures and pressures [6].

When co-generation systems are also considered, the efficiency figures increase even more. For a case study discussed in [8], the electrical efficiency had been calculated at 43% with an overall efficiency of 85%. However, a detailed description of the calculation procedure is not presented in [8].

According to the test run results of another case study in Germany for a 79 kW_{dc} PAFC, electrical efficiency has been found to be in the range of 46~49%, under various operating conditions. For this case study, low heat value is used for the fuel and refers to the dc power output.

Modes of Operation

The following four modes of operations are identified for FC systems as distributed generators in [2].

1. Production of constant real power and constant VARs

This is considered as the normal operating mode of a FC connected to a “stiff” grid. (Voltage and frequency of a stiff system are least affected by changes in power production of FC.) The dynamics of this mode of operation are determined by the plant itself and not by the network. For this type of connection faster and more flexible FCs have a greater advantage over other generators in the network.

2. Production of reactive power for bus bar voltage compensation

In this mode of operation the VARs generated by the FC are used to stabilize the load bus bar voltage or to implement a voltage-VARs droop characteristics. For this mode to be viable, local bus bar voltage of the network should be reasonably “weak” (low voltage) at the point of intersection. This operating mode is controlled by the PCU and has no influence on FC stack.

3. Production of real power for system frequency compensation

To be run on this mode, the FC capacity rating should be relatively high. But at present, because of lower ratings of present FC systems this mode is considered as a long-term prospect.

4. Load following mode

The FC can be in this operation mode when supplying domestic power requirement using the grid as a backup. When the FC is supplying a domestic demand it must satisfy all the electrical demand without allowing a voltage drop at its terminal.

A FC may face a similar situation when a grid-connected plant is islanded; that is, when the plant instantly experiences a transition from full power to almost zero power yet having to maintain a stable voltage for its auxiliary supplies. Batteries and resistive load may be used to overcome problems of load following.

A typical grid connected system is discussed in [3]. Before interconnecting the FC distributed generator to the grid, the utility had requested a load profile study for the system to ensure that the fuel cell generation would not cause feedback of power to the network under any circumstances. The facility discussed in this report is fed with two 14.4 kV feeders from the utility and the metering for this system is comprised of watt-hour meters at feeders and a demand storage unit. There is an additional recorder to record the load profile of the facility. A typical single line electrical diagram for a FC system is explained in [3].

2.4 Economic Analysis

Cost models for FC distributed generation systems

An economic cost model should incorporate both the investment costs and operating costs of the FC system. Total Module Cost includes the equipment cost, and other direct and indirect installation costs. These installation components are referred to as the capital cost. Techniques available for estimating these costs are further discussed in [10].

Having realized the above costs, 'a levelized annual cost' of the investment can be obtained. This is equivalent to the minimum constant revenue required each year of the life of the project to cover all expenses. In other words, the levelized cost gives the annual revenue or purchase energy savings that would be needed for the FC project to be economically feasible under equivalent reliability and power quality levels.

The amount of annual energy cost saved depends on the rate of electricity and natural gas. Waste heat from a FC may be used for cogeneration so the energy savings should

include savings due to the cogeneration systems as well. The effective electricity rate should include both demand and energy charges. Since FC power is reliable and of high quality, the rates may be more than the utility effective rates. If the FC is to eliminate costly shutdowns and cost of UPS, the rate may be even higher [4].

When the system is connected to a utility, it is important to verify that a fair price for a kWh is given by the utility. This will place the distributed generator in fair competition with other generators in the network. Therefore, economic evaluation for a FC distributed generation system shall include both financial and economic costs and benefits. A simple financial analysis would fail to capture the true economic benefits of these systems [11].

Economic benefits for FCs are twofold. They may be used in pricing of energy.

Energy benefits = F (energy saved by the Distributed Generator, Avoided cost of energy, environmental externalities, Line loss multipliers)

Capacity benefits = F (system kW reduction, T & D loss multiplier, Reserve margin multiplier, Avoided capacity costs, marginal T & D costs)

It is difficult to directly identify and quantify externalities involved (such as environmental impact). These are usually described more qualitatively or as an adjunct to the cost/benefit analysis in a typical evaluation report [12].

3.0 Technical Performance

The electrical performance evaluation includes electrical efficiency calculations, reliability calculations, and power quality analysis. For this report, the performance parameters were obtained and calculated from the data available from a 200 kW PAFC fuel cell installed at City of Mesa site.

3.1 Performance Parameters

Given below are some of the important calculated performance parameters.

Capacity Factor (Net): The ratio of the net electricity generated, for the period of time considered, to the energy that could have been generated at continuous full-power operation during the same period.

Net electricity generated = 1,425,891 kWh (from 4/29/00 to 4/03/01)
Energy at 100% availability = 1,630,757 kWh (from 4/29/00 to 4/03/01)

Capacity Factor (Net) = 87.4%

Natural gas input = 1,899 scfh
= 1,899 kBtu/h

Net Heat Rate = 10,073 Btu/kWh

(Calculations are based on natural gas with a HHV of 1,030 Btu/ft³)

Annual natural gas consumption = 15,803 Mcf/yr
Annual fuel cost = 63,264 \$/yr

(Considering an availability of 95% for the fuel cell)

Fuel cost/energy unit = 0.038 \$/kWh (@ nat. gas rate of 4.0 \$/Mcf)
= 0.047 \$/kWh (@ nat. gas rate of 5.0 \$/Mcf)
= 0.057 \$/kWh (@ nat. gas rate of 6.0 \$/Mcf)

Operational and maintenance cost = 4.81 mills/kWh

(For a fixed annual O&M cost of \$8,000.)

Electrical efficiency = 33.9%

Thermal heat available = 880 Mbtu/h

Overall efficiency = 79.9%

Availability = 91.0% (from April 2000 to April 2001)

3.2 Energy Balance

Energy input/output model

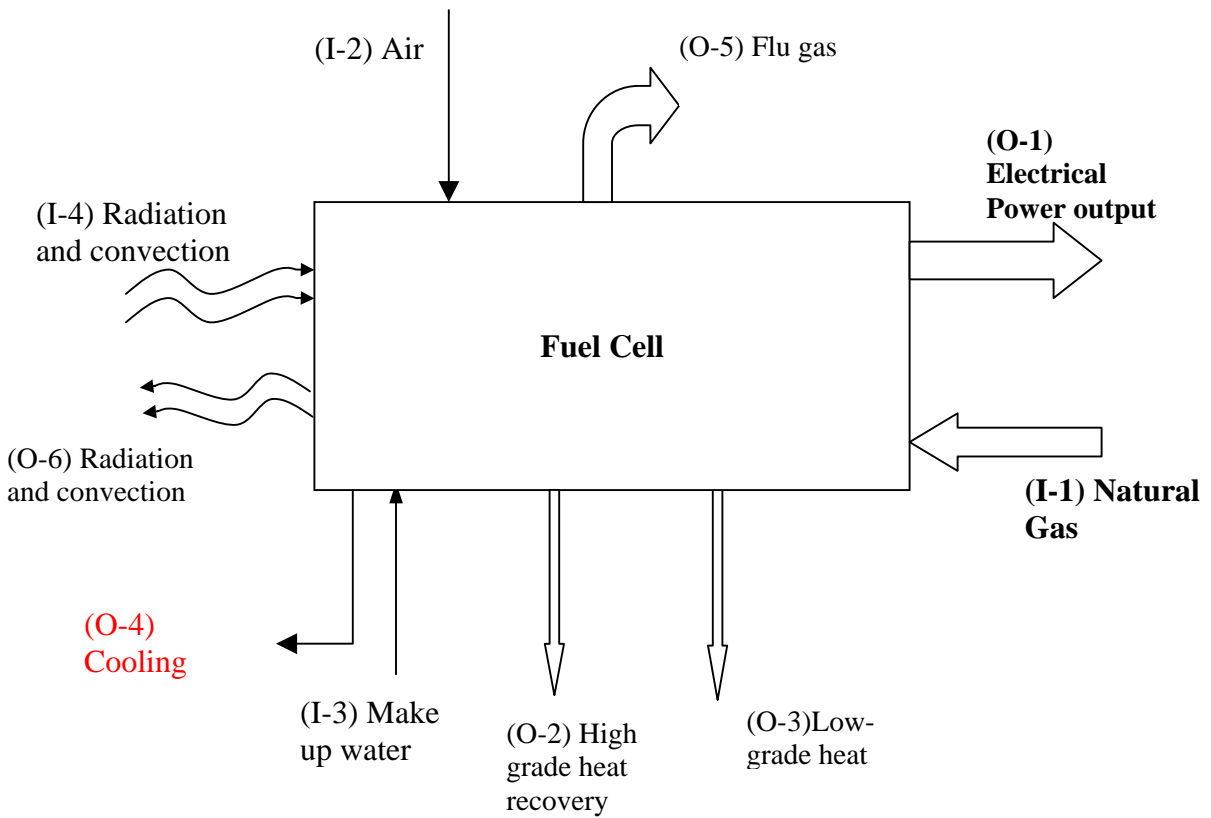

Figure 3.1: Input/output heat flows for the energy/mass balance

Energy Input		Energy Output	
<u>(I-1) Natural Gas</u> Flow rate = f Temp./ Pressure/ moisture = T, P, h % HHV at T, P, h= H, Nat. Gas density at, T, P, h = d Heat inflow, I-1 = f x d x H MBtu/h	I-1	<u>(O-1) Electrical</u> Electrical output, O-1 = (INV_IVAB x INV_IA x pf1) + (INV_IVBC x INV_IB x pf2) + (INV_IVCA x INV_IC x pf3) Equivalent heat inflow, I-1 in MBtu/h	O-1
		<u>(O-2) High Grade Heat Recovered</u> Measured BTU = H BTU/h Heat rate, O-2 = O-2 MBtu/h	O-2
<u>(I-2) Inlet Air</u> Air Flow rate = f Temp. Pressure, moisture = T, P, h % Sp. Heat at T, P, h = H, Air density at, T, P, h = d Heat content, I-2 = f x d x H MBtu/h <i>Note: Alternatively from the fan motor rating or, stoichiometric analysis.</i>	I-2	<u>(O-3) Low Grade Heat Recovered</u> Measured BTU = H Heat rate, O-3 = O-3 MBtu/h	O-3
		<u>(O-4) Cooling Fans</u> Measured BTU = H Heat rate, O-4 = O-4 MBtu/h	O-4
<u>(I-3) Makeup Water</u> Water Flow rate = f Temperature and Pressure T, P Specific Heat at T, P= H, Water density at, T, P= d Heat content, I-3 = f x d x H MBtu/h	I-3	<u>(O-5) Exhaust Gas</u> Air Flow rate = f Temp. Pressure, moisture = T, P, h % Sp. Heat at T, P, h = H, Air density at, T, P, h = d Heat content, O-5 = f x d x H MBtu/h	O-5
<u>(I-4) Other</u>	I-4	<u>(O-6) Other</u>	O-6
TOTAL ENERGY INPUT = TOTAL ENERGY OUTPUT			

Table 3.1: Energy/mass balance calculation format

$$\begin{aligned} \text{Fuel Cell Efficiency without considering heat recovered} &= \text{Electrical output/Fuel input} \\ &= (\mathbf{O-1})/(\mathbf{I-1}) \end{aligned}$$

$$\begin{aligned} \text{Fuel Cell Efficiency considering heat recovered} &= (\text{Electrical output} + \text{Heat} \\ \text{Recovered})/\text{Fuel input} &= (\mathbf{O-1} + \mathbf{O-2} + \mathbf{O-3})/(\mathbf{I-1}) \end{aligned}$$

$$\begin{aligned} \text{Fuel Cell Electrical Efficiency} &= \frac{(\text{Electrical Output})}{(\text{Fuel Input})} \\ &= \frac{(O-1)}{(I-1)} \end{aligned}$$

3.3 Fuel Cell Stack Performance

After analyzing the downloaded electrical parameters, some observations were made on certain electrical performance aspects of the fuel cell. A trend analysis on the fuel cell stack voltage indicated that there was an observable weakening of the stack voltage with the cumulative electrical energy produced by the fuel cell (Figure 3.2). In addition (and as has been anticipated) there was an observable variation of the stack voltage against the dc current drawn (Figure 3.2).

The inverter efficiency showed a slight declining trend with the fuel cell usage over a period of time (Figure 3.3). This could be attributed to the fact that the increased dc current with the decaying voltages had resulted in increased losses in the inverter. A plot showing how the dc current increased with the cumulative energy produced is shown in Figure 3.4. The impact of these variations on the total fuel cell efficiency and performance will be possible when more data is available.

Further analysis is being done to develop a practical model to predict the stack voltage probable failures of the system due to low stack voltage. A suitable stack replacement schedule can also be predicted well in advance based on stack voltage decaying criterion.

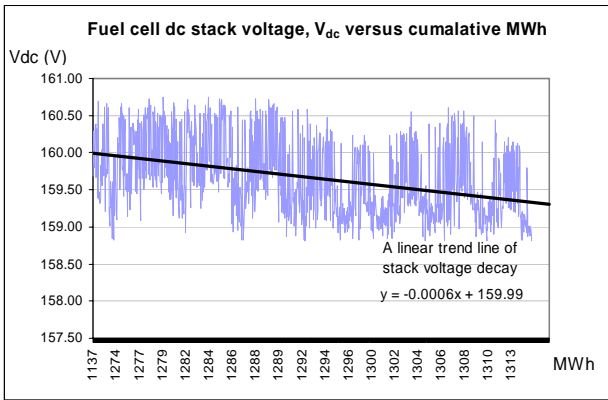

Figure 3.2: Fuel cell dc stack voltage, V_{dc} versus cumulative MWh

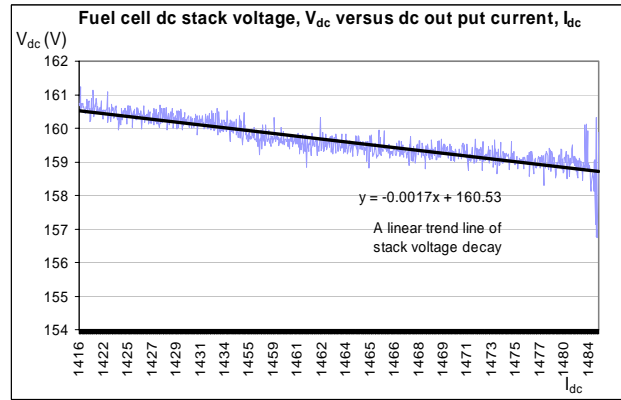

Figure 3.3: Fuel cell dc stack voltage, V_{dc} versus dc output current, I_{dc}

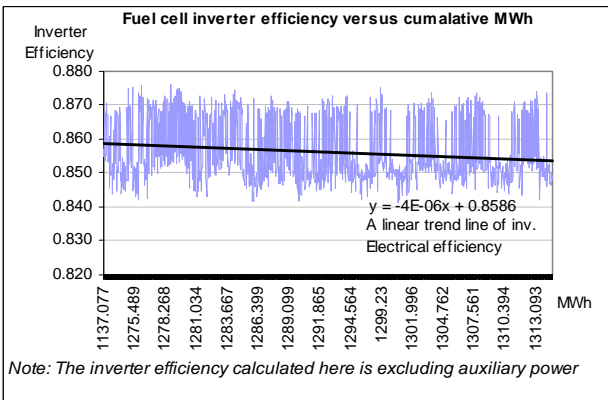

Figure 3.4: Fuel cell inverter efficiency versus cumulative MWh

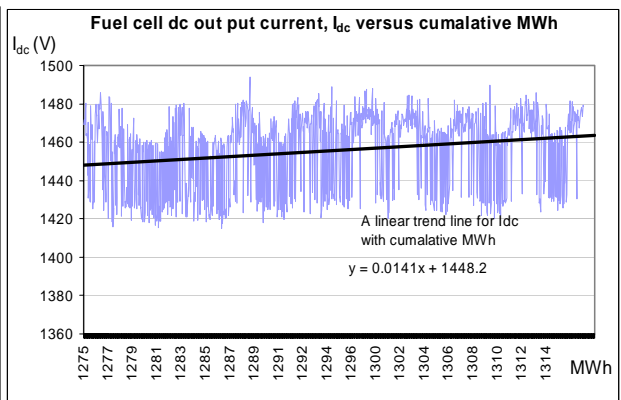

Figure 3.5: Fuel cell dc output current I_{dc} , versus cumulative MWh

The above-mentioned inherent FC stack characteristics are to be incorporated into an analytical model of the fuel cell. This will enable us to determine how the fuel cell will respond under various operating conditions of distributed generation.

4.0 Thermal Performance

4.1 Introduction

This section presents thermal utilization details and other relevant thermal considerations for the fuel cell in this case study.

One of the main advantages of the fuel cells is the additional thermal heat available as a byproduct in the electrochemical reaction. Different types of fuel cells offer different thermal heat quantities at different temperatures. The fuel cell under investigation, which is of the Phosphoric Acid type, is said to be operating at medium level temperatures compared to other types of fuel cells. The thermal usage of a fuel cell in distributed generation depends on the application for which the fuel cell is being used. The possible installation options available for a fuel cell vary widely, depending on how the electricity is being used and whether any thermal energy is being recovered. The economic evaluations have shown that fuel cells are most beneficial when the cogeneration options are fully utilized.

4.2 Site Details

Initial site selection efforts for the fuel cell will have to consider, among other factors, the potential applications of thermal utilization of the fuel cell. Typical thermal utilizations with a 200 kW PAFC could be found in space heating, absorption refrigeration systems, domestic hot water needs, swimming pools, laundry in a hotel building, etc. In the case of the fuel cell in this study, the fuel cell heat had been used for an absorption chiller system, space heating and domestic hot water supply. (Table 4.1 and Figure 4.1)

It is also important to see whether the available heat from the fuel cell would replace an existing thermal facility or whether it is going to be incorporated in a new thermal facility in a new installation. This is important in quantifying the avoided costs and savings from the fuel cell. The 200 kW fuel cell in this case had been installed in a new office building. The heat recovery from the fuel cell had been incorporated in the initial thermal design of the office building. The heat recovery from the fuel cell had been taken into account when deciding on the capacities and rating of the other thermal equipment and interfaces.

The fuel cell site had been selected to be an adjoining location to the building and close to the other existing thermal facilities.

4.3 Heat Recovery Systems

Both high-grade and low-grade heat available from the fuel cell are recovered for cooling, heating and domestic hot water requirement of the building. The high-grade heat

recovery is used for concurrent heating and cooling systems of the building. The low-grade heat is utilized in the supply of domestic hot water requirement of the building.

4.3.1 Cooling System

The absorption chiller provides for the cooling requirements of the building. The hot water requirement (288 GPM at 240 °F) for the chiller is generated from a natural gas fired boiler. The fuel cell high-grade heat is used to supplement boiler inlet feed. The high grade heat from the fuel cell, (240 °F, @24 GPM) increases the boiler feed water temperature to 217 °F.

The chiller operation is shut off when the external air temperature goes below a preset value during winter periods. When the chiller is shut off, the condensed water from the cooling tower is diverted to heat exchanger-1 to provide for the cooling requirement under economizer operation.

4.3.2 Heating System

The boiler provides for the heating requirements of the building. When the chiller is in operation for cooling duty, the hot water out from the chiller is fed to the plate and frame heat exchanger-2, to recover heat for heating requirements. When the chiller is shut off, the boiler would still feed the heat exchanger-2 to provide for building heating requirements. The contribution of the fuel cell to the heating system is found in the use of high-grade heat to supplement boiler inlet feed.

4.3.3 Domestic Hot Water

The low-grade heat from the fuel cell is utilized at the domestic hot water storage tank with a double wall heat exchanger. The low-grade heat is supplied to the double wall heat exchanger whenever the storage water temperature drops below a preset value (120 °F).

4.4 Available Heat from the Fuel Cell

The low-grade fuel cell heat feeds a heat exchanger to supply domestic hot water requirements for the building. The high-grade fuel cell heat is supplied to a boiler feeding an absorption chiller. The outgoing heat from the chiller is fed to another heat exchanger for further recovery as shown in Figure 4.1.

The high-grade heat leaves the fuel cell at 240 °F and the low-grade heat at 140 °F.

Heat Source	Utilization	Temperature	Heat Quantity
Fuel cell high grade heat	Supplement boiler feed water	240 °F	750 mbtu/h <i>approximately</i>
Fuel cell low grade heat	Utilized at the domestic hot water exchanger/storage	140 °F	120 mbtu/h <i>approximately</i>

Table 4.1: Fuel cell high grade and low-grade heat utilization

Note: The heat quantities indicated above are typical values for similar installations. The actual recovery depends on the actual temperatures and the liquid flow rate.

The actual heat displacement due to the fuel cell depends on the actual thermal loading of the building. For example, the space heating requirement could vary throughout the year. The building heat requirement during the summer months could be lower and it may not be required to fully utilize the fuel cell's available heat. Under these circumstances, the fuel cell heat could be used for supplementing cooling requirements. The actual natural gas displacement due to the fuel cell also depends on the efficiency of the equipment being supplemented or displaced.

The annual natural gas displacement from the boiler due to the fuel cell utilization could be calculated as follows. A boiler efficiency of 70% and full thermal utilization of the fuel cell has been assumed. An availability factor of 95% for the fuel cell has also been assumed.

Nat. gas displacement = {(heat displaced, Mbtu/yr) x (FC availability, %)} / (boiler efficiency, %)

Heat displaced = (FC available heat, mbtu/hr) x (Annual usage, hr/yr)

FC heat source	Heat available (Mbtu/h)	Annual Heat displaced (Mbtu)/year	Annual Nat. gas displaced (Mbtu/year)
High Grade Heat	750	6,570,000	8,916,428
Low Grade Heat	120	1,051,200	1,426,628
Total	880	4,380,000	5,631,428

Table 2.0: Heat displacement due to fuel cell thermal utilization

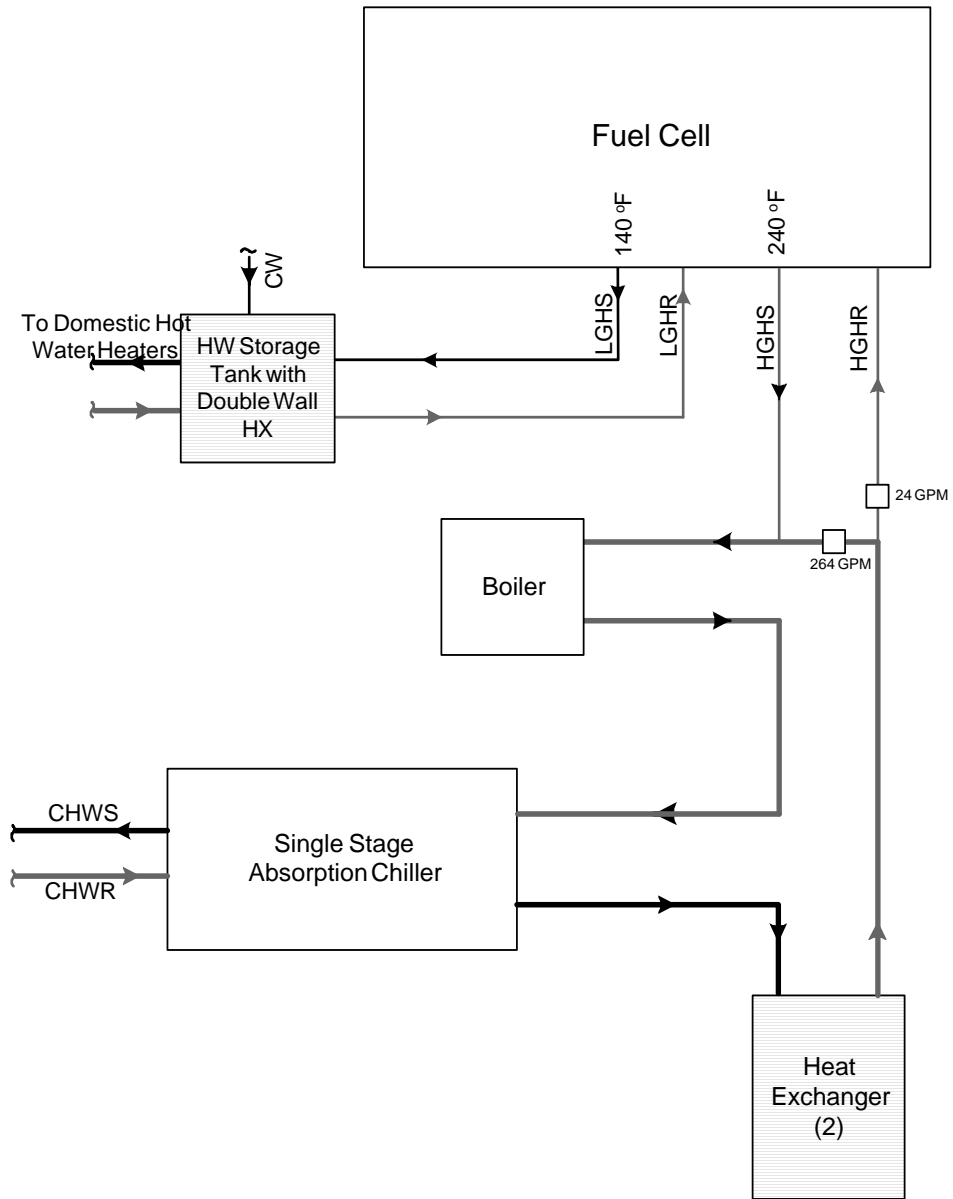

Figure 4.1: A simplified layout of the high grade and low grade heat recovery system

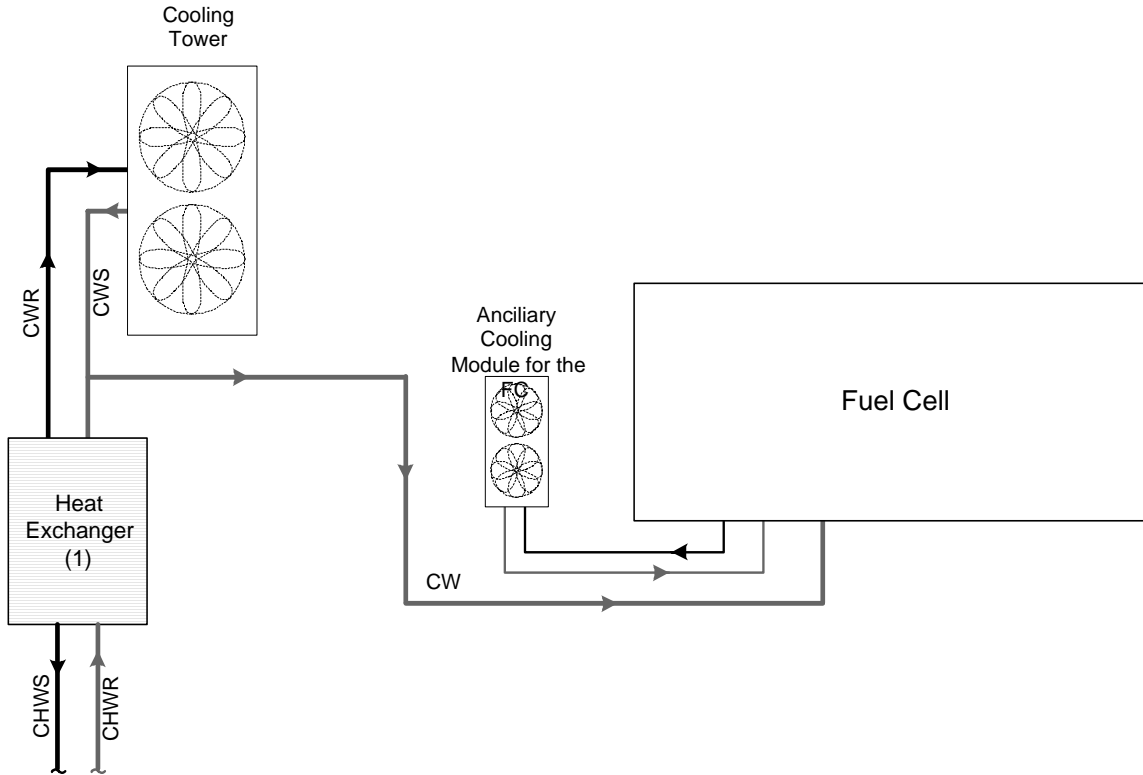

Figure 4.2: Ancillary cooling and makeup feed water arrangement

4.5 Details of Thermal Equipment Used (at City of Mesa Installation)

4.5.1 Single Stage Steam Absorption Chiller

Type:	Single stage absorption
Capacity:	212 Tons (Minimum)
Efficiency:	0.67 C.O.P (Minimum)
Liquid Used:	Water
Evaporator Inlet/Outlet:	54 / 44 °F, @500GPM
Absorber Inlet/Outlet:	85 / 100 °F, @850GPM
Generator Inlet/Outlet:	240 / 210 °F, @288GPM

4.5.2 Gas Fired Hot Water Boiler

Type:	Bent Steel Water Tube
Fuel:	Natural Gas
Output Capacity:	3, 312,000 BTUH (Minimum)
Water Inlet/Outlet:	217 / 240 °F, @288 GPM

Thermal Efficiency: 80% (Minimum)

4.5.3 Cooling Tower

Type: Induced draft
Entering Air Temp.: 79 °F (wet bulb)
Water Inlet/Outlet: 100 / 85 °F, @288 GPM

4.5.4 Plate and Frame Heat Exchanger (1)

Hot side Inlet/Outlet: 58 / 53 °F, Water @418 GPM
Cold side Inlet/Outlet: 50 / 53 °F, Water @712 GPM

4.5.5 Plate and Frame Heat Exchanger (2)

Hot side Inlet/Outlet: 217 / 211 °F, Water @288 GPM
Cold side Inlet/Outlet: 160 / 179 °F, Water @82 GPM

4.6 End Notes

Some of the exact thermal details for the installation site were not available at the time of preparing this report. For example, the actual temperatures and flow rate details for some of the thermal interfaces were not available. In such cases, the typical and estimated values have been used.

5.0 Economic Model

5.1 Introduction

This section of the report presents details of the economic model developed for a fuel cell as a distributed generator. Previous work towards development of economic models for battery energy storage units, induction motors and fuel cells were found from the literature review. Different approaches and methods have been suggested and some relevant concepts described therein were referred to in developing this model.

The objectives of this effort include arriving at a flexible model so that the same model could be used for other fuel cells with little or no modifications. The model output includes typical economic measures for an investment evaluation.

5.2 Modeling Techniques

The influence diagram concept used in modeling of a battery energy system [18] is followed in identifying the model parameters (Figure 5.1).

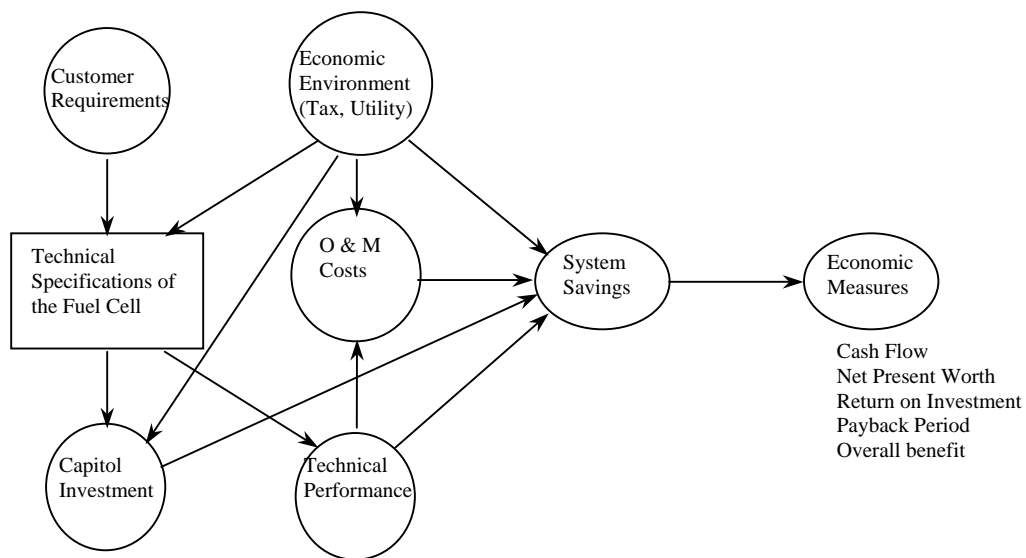

Figure 1.0: Influence diagram for the economic model.

5.3 Spreadsheet Implementation

The economic model was implemented using Microsoft Excel. Given below is the detailed description of the spreadsheet model. Different input parameters to the model are identified with explanation to the data entry. Representation and analysis of output results are also explained.

For the ease of data input, results and other details are displayed in different screens of the Excel spreadsheet. Navigation buttons and automated calculations are implemented using macros and simple Visual Basic codes. The user friendly Excel environment is still maintained for program modifications and alterations.

Note: Click 'Enable Macros' when opening the economic model spreadsheet program.

5.4 Data Input

Input screen for data entry can be accessed by clicking the 'Input Screen' button visible in screens other than the input screen. The input screen can be easily accessed to view or change the input data.

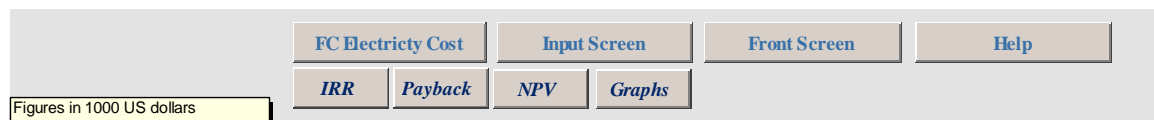

Figure 5.2: Navigation buttons

The input screen is further categorized under Fuel Cell Data, Energy Rates, Energy Requirement, and Accounting Details. The input parameters that may be entered or altered are indicated in 'dark blue' color. Some of the calculated parameters are also displayed in the screen but are disabled to avoid accidental alteration of formulas. Some of the important input details are explained below.

Economic Measures		Front Screen		Help	
Input Data					
Fuel Cell Details					
Number of fuel Cell Units			1		
Technical Characteristics			per Unit	Total	
Capacity (kW)			200	200	
Derating Factor (DF)			0%	-	
Available Capacity (kW)			200	200	
Fractional Efficiency %			36%	-	
Un-planned outage hours (h/year)			100	100	

Figure 5.3: Input Screen

5.4.1 Fuel Cell Details

The fuel cell performance and cost details are entered in the first segment of input parameters. Some of the technical and performance details need to be entered in the specified units. The technical and performance data are to be obtained from the manufacture-supplied data or from available past and/or typical data. A calculated ‘Total’ column is displayed to the right of fuel cell input data and is used for calculations when the number of fuel cell units is more than one. This column is disabled for alterations.

Overhauls: Provisions for two overhauls are included within the total life span of 20 years for the fuel cell. Care should be taken in entering the overhaul year numbers and overhaul cost depreciation years (under ‘Accounting Detail’ category) so that the overhaul cost would be appropriately depreciated before the end of the accounting project life.

Fuel Cell thermal energy: Data on fuel consumption and thermal heat available are entered under this input category. Thermal heat available is the total heat available from both high grade and low grade. This thermal heat available is used for quantification of heat displacement from cogeneration depending on the thermal energy requirement and the recovery details of the installation.

5.4.2 Energy Rate Details

Utility electrical tariff details and the fuel cell fuel tariff details are entered under this subcategory. Energy tariff details are critical in deciding on the economic feasibility of the fuel cell project. Hence every effort is taken to accurately model and calculate the energy rate details.

Different Electricity Tariff Plans: Provisions are given to choose between two applicable electricity tariff plans for the utility supplied electricity to the installation. The user can choose between the Standard Price Plan and the Time-of-Use Plan by clicking one of the command buttons at the top of the energy rate details input section. When a

command button is clicked, an input screen for the selected plan appears with already entered, typical data for the selected plan. New input values may be entered as required.

Time-of-Use Plan: This plan bills the electricity energy supplied by the utility based on electricity usage at three different time slots: on peak, shoulder peak, and off peak usage. Different energy and demand charges may be applicable during summer and winter months. The SRP, Arizona, E-32 Time-of-Use plan is used as a model for input configurations and calculations. Following important facts may be noted for this plan when entering data.

- On/shoulder/off peak durations should be identified for weekdays and weekends
- Durations, energy and demand charge may be different for summer and winter.

Standard Price Plan: The standard price plan calculates the billing based on several energy (kWh) blocks and a demand charge. The blocks are identified as energy block per kWh used. Four such blocks are provided and if required, less than four blocks may be used by entering zeros in unwanted latter blocks. SRP, Arizona, E-36 Standard Price Plan is used as a model for input configurations and calculations.

Standard Price Plan (Block Tariff)	kWh/kW	Summer		Winter	
		First Block (kWh/kW demand)	180	0.0763	0.058
Second Block (kWh/kW demand)	155	0.0558	0.0482		
Third Block (kWh/kW demand)	130	0.0416	0.0324		
Balance		0.0347	0.0294		
Demand charges (\$/kW/month)		3.39	1.67		

Figure 5.5: Input format for the standard price plan tariff

Natural Gas Prices: Natural gas prices for the installation are subject to two price schemes. Natural gas for fuel cell usage is considered under a reduced cogeneration gas rate and the natural gas usage by other thermal equipment at another rate. Reduced cogeneration gas rates can be used only for fuel cell usage. (Southwest Gas Company: Cogeneration Gas Service, G60 Plan). For the general gas service plan (Southwest: G25), both an energy charge and a demand charge are levied. For the purpose of energy savings calculations, an effective rate may be used considering estimated energy usage and billing determinant of the customer.

Demand charge per month = Demand Charge x Customer's Billing Determinant

Billing determinant is the customer's throughput during the month in which utility's peak is established. For a new customer, throughput could be calculated as the estimated average monthly throughput. (Source: Southwest Gas Company)

In the absence of estimated values, and for the purpose of calculation an additional percentage of demand charge may be added to approximately account for the billing determinant.

Monthly Energy Service Charges: The monthly service charges for both electricity and gas need not be entered since those charges are not required for quantifying the savings due to the fuel cell.

Energy Escalation Rates: Appropriate energy escalation rates are important in calculating the actual cash flows for the financial analysis. These escalation rates would be reflected in the actual cash flow statement as increments in energy costs or savings in successive future years. If different energy sources have different energy escalation rates, those could be important in calculating and analyzing net present values and rate of returns.

Fuel Cell Generated Electricity Prices: This is the price at which the electricity supplied to the grid by the fuel cell is quantified. The cost of fuel cell electricity can be determined using some of the fuel cell electricity cost calculation formulas given in the literature.

$$COE = \frac{0.125CC}{H} + \frac{3.412FC}{\epsilon} + \frac{OM}{H}$$

Where,

- CC: Capital Cost in \$/kW
- FC: Fuel Cost in \$/MMBtu
- e: Fractional Efficiency
- H: Annual Operating Hours/1000 in hrs
- OM: Operating and Maintenance Cost in \$/kW-yr total, including fixed and variable costs

The cost calculated using this formula might be used in determining the fuel cell electricity selling prices by adding an appropriate sales margin. Such a selling price however does not reflect the capacity reduction benefits derived by the utility by the fuel cell supplied power. However, the actual selling prices would depend on a purchase agreement with the utility. In the absence of such arrangement with the utility, the general tariff details may be entered for the grid supplied electricity prices. If a demand charge is not applicable the user may enter zero at demand charge value entries.

Note: The spreadsheet program calculates the cost of electricity based on the above formula and based on input data. That value may be obtained by typing '=COE' in an input data entry cell.

Energy Supplied to the Grid: It is also important to quantify the energy supplied to the grid by the fuel cell. The energy supplied needs to be entered as a daily energy (kWh) supplied to the grid. If a time-of-use plan is considered then the energy supplied needs to be entered as a daily value for different time slots. The value entered should not exceed the energy available from the fuel cell for the day or time slot which is indicated just above the data entry location. If exceeded an error message would appear.

The actual or estimated load profiles of the installation can be used in quantifying the energy supplied to the grid by the fuel cell.

5.4.3 Annual Energy Requirement of the Site

Both electrical and thermal energy requirements need to be entered to calculate savings due to the fuel cell. The electrical energy requirements for the site need to be entered as a peak demand and a load factor for a particular time slot or season. Whether the data must be entered on a daily or a particular time slot basis would depend on the initially selected tariff plan for the site. The annual thermal load is also needed to calculate the savings due to thermal utilization of the fuel cell. The efficiency of equipment that the fuel cell would fully or partially displace is also required for the calculations.

5.4.4 Accounting Details

One of the important accounting parameter is the discount rate at which the future cash flows would be discounted, for present value calculations. The discount rate selected may depend on, among other factors, the accounting policy, cost of funds, and the nature of business of the fuel cell owner. The life spans of the capital investments also have to be entered as input data.

5.5 Calculation Procedure

Costs and savings of energy for the fuel cell site are calculated based on the input data acquired. Some of the important calculation procedures, assumptions and approximations are discussed below.

5.5.1 Reliability Parameters

Reliability parameters for the fuel cell are calculated using the following formulas and are used in actual available capacity of the fuel cell. It is the actual available capacity after deducting outages (both scheduled and forced) that is used in quantifying the energy savings. The hours lost due to scheduled overhaul maintenance are also taken into account in calculating the available capacity from the fuel cell.

5.5.2 Electrical Energy Savings

Electrical energy savings are calculated for both electrical energy displaced by the fuel cell and electrical energy supplied to the grid. Savings due to demand charge savings are also calculated.

Savings on energy charge

When the actual or estimated load factor and the peak load for a particular time period is known, the energy served is given by the following equation.

$$\text{Load Factor} = \frac{\text{Energy_Served_in_a_time_period_T}}{(\text{Peak_Load}) \times T}$$

The electrical energy supplied by the utility in the absence of the fuel cell (E1) can be thus calculated using the above equation.

$$\text{Electrical energy supplied by the utility in the absence of fuel cell} = E1$$

When the fuel cell is in operation and is grid connected, the amount of fuel cell electricity supplied to the grid depends on the load profile of the site and the fuel cell available

capacity. It is assumed that when the load profile curve drops below the fuel cell power capacity, the excess energy is supplied to the grid. The estimated energy supplied to the grid is entered to the model as an input parameter.

The utility electrical energy supplied, when the fuel cell is in operation (E_3) is calculated as follows.

FC electrical supld. to the facility, $E_2 = (FC \text{ available energy} - \text{Energy supld. to the grid})$

Electrical energy supld. by the utility with the FC in operation, $E_3 = E_1 - E_2$

Cost of utility electricity depends on the energy supplied and the applicable tariff structure. This is indicated as a function of energy and tariff structure in the following equations. For the same amount of electrical energy displacement by the fuel cell, the amount of saving could be different for two different tariff schemes.

Cost of utility electricity in the absence of fuel cell = $C_1 = f(E_1, \text{Tariff Structure})$

Cost of utility electricity with the fuel cell = $C_2 = f(E_3, \text{Tariff Structure})$

Electrical energy charge saving = $C_1 - C_2$

Savings on demand charge

When the fuel cell is in operation, and when the facility peak demand is more than the available fuel cell capacity, it is assumed that the total fuel cell capacity is used to shave the peak demand. Therefore, the peak demand reduction would be the capacity of the fuel cell. When the fuel cell capacity is more than the peak demand of the facility, the total peak would be shaved.

***Note:** A reduction in peak demand may also result in a reduction in energy charges, in a block tariff structure since the kWh energy block calculations depend on the peak demand. This is taken into consideration in the program.*

Income from the FC electricity supplied to the grid

Given the amount of energy supplied and the selling price of the fuel cell electricity the income from the FC electricity supplied to the grid can be calculated.

5.5.3 Thermal Energy Savings

As has been explained in section 4.4, the actual heat displacement due to the fuel cell depends on the actual thermal loading of the building. The actual natural gas displacement due to the fuel cell also depends on the efficiency of the equipment being supplemented or displaced.

The annual natural gas displacement of the boiler due to the fuel cell utilization could be calculated as follows. An availability factor for the fuel cell may also be considered for the calculations.

Nat. gas displacement = {(heat displaced, mbtu/yr) x (FC availability, %)} / (boiler efficiency, %)

Heat displaced = (FC available heat, mbtu/hr) x (Annual usage, hr/yr)

The cost of fuel cell fuel consumption is calculated at the cogeneration gas rates and the savings on gas displacement are calculated at the natural gas price for general services.

5.6 Output Results and Economic Analysis

The annual costs and savings due to the fuel cell are used in preparing the actual cash flow statement throughout the lifetime of the fuel cell. A life span of 20 years is assumed for the calculations. Annual costs, savings, capital investments and depreciations are identified in separate subcategories. Depreciations have been calculated to identify the taxable income of the project. Double declining balance method is used for the depreciation calculation. The user may change the depreciation calculation method by entering the appropriate formula in the cell. It must also be noted that the annual costs and savings may not remain fixed due to energy escalation rates.

		FC Electricity Cost	Input Screen	Front Screen	Help		
Figures in 1000 US dollars		IRR	Payback	NPV	Graphs		
Cash Flows and Economic Measures							
Year		0	1	2	3	4	5
<u>Energy Cost Savings with Fuel Cell</u>							
Saving on Electrical Energy Charges	-	74	76	77	79	80	
Saving on Maximum Demand Charges	-	6	6	6	6	6	
Saving on Natural Gas (utilization of FC Heat)	-	58	59	60	62	63	
Income from Electricity Supplied to the Grid	-	61	62	64	65	66	
Cost of Natural Gas for Fuel Cell	-	(101)	(103)	(105)	(107)	(109)	
Income from Fuel Cell	-	98	100	102	104	107	

Figure 5.6: Output screen showing the cash flows

Such economic measures as, Net present Value, Pay Back Period, and Internal Rate of the project are calculated and displayed. Some of the output results are graphically represented. The user can vary the input parameters by navigating back to the input screen and entering new data.

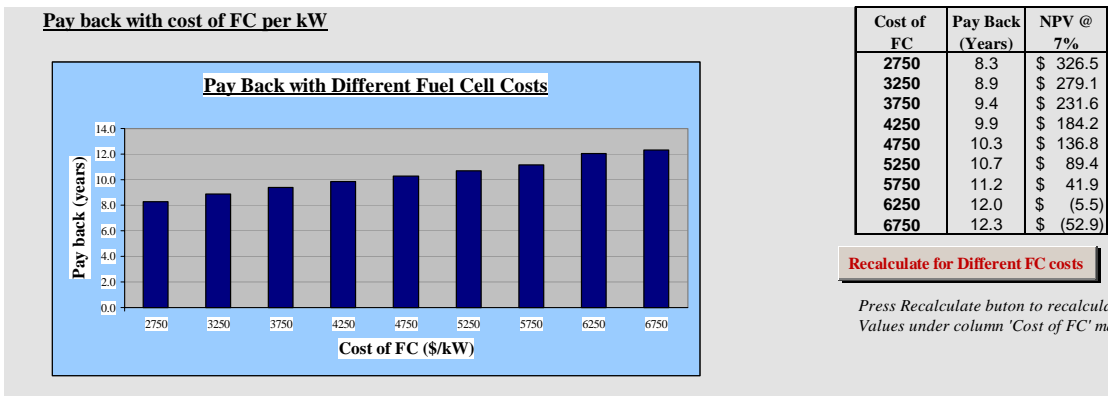
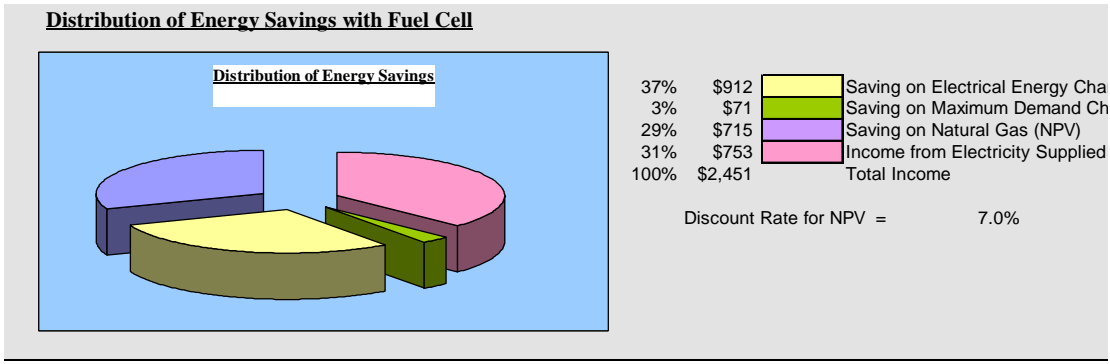

Figure 5.7: Sample graphical output results

5.7 End Notes

The economic model for the fuel cell is to be used with a typical fuel cell application as a distributed generator. This spreadsheet model may be used with some flexibility under different scenarios and within the typical application scope of a fuel cell as a distributed generator.

6.0 Conclusion and Future Work

The overall scope of the project was to study the system performance and operation of a fuel cell distributed generator, and to provide an assessment of the electrical, thermal, and economic issues associated with the fuel cell system. This report provides fundamental information about the technical description and economic decision-making model for a fuel cell.

It would be of interest to study the other applications of the fuel cell, in providing ancillary services to the utility. Such an investigation would involve investigating both the applicability and feasibility of such ancillary applications.

To investigate the fuel cell dynamic interactions with the local utility network, a dynamic model for the fuel cell as a distributed generator is being developed. Different component models available for the fuel cell are being studied to devise a comprehensive dynamic model for the fuel cell. Upon completion of the model, the same model is to be used to study how the fuel cell would respond under different operating conditions of the network and the local loads.

It would also be of interest to use the existing network configuration of the utility, but assess connection of the fuel cells at different nodes in the network to study the performance and impact on the utility network due to such connections.

Reference:

- [1] K.M. Salim, Z. Salam, F. Taha, A.H.M. Yatim, "Development of a fuel cell power conditioner system," *Proceedings of the IEEE 1999 International Conference on Power Electronics and Drive Systems, 1999, PEDS '99*, vol. 2, 1999, pp.1153 –1156.
- [2] J. Padulles, G. W. Ault, J.R. McDonald, "An approach to the dynamic modeling of fuel cell characteristics for distributed generation operation," *IEEE Power Engineering Society Winter Meeting*, vol. 1, 2000 , pp. 134 –138.
- [3] Y. Kishinevsky, S. Zelingher, "A 200 kW ONSI fuel cell on anaerobic digester gas," *Power Engineering Society Summer Meeting*," vol. 1, pp. 564 –567.
- [4] D.H. Archer, J.G. Wimer, M.C. Williams, "A phosphoric acid fuel cell cogeneration system retrofit to a large office building," *Proceedings of the 32nd Intersociety Energy Conversion Engineering Conference*, vol. 2, pp. 817 –824.
- [5] Y. Kuwata, T. Babasaki, M. Iwasawa, T. Koyashiki, "Input current controlled DC interconnection converter for fuel cell systems" *16th International Telecommunications Energy Conference*, pp. 375 –380.
- [6] R. Anahara, S. Yokokawa, M. Sakurai, "Present status and future prospects for fuel cell power systems," *Proceedings of the IEEE*, vol. 81 No.3, March 1993, pp. 399 –408.
- [7] J.M. Carrasco, E. Galvan, F.P. Ridaio, F. Barrero, L.G. Franquelo, F. del Pozo, J. Toro, "Microcomputer control of a fuel cell power system," *20th International Conference on Industrial Electronics, Control and Instrumentation*, 1994, vol. 1, pp. 473 –478.
- [8] M.J. Kornblit, K.A. Spitznagel, "Installing a fuel cell on an existing power system," *Conference Record of the 1993 IEEE Industry Applications Society Annual Meeting, 1993*, vol. 2, pp. 1379 –1383.
- [9] J. Hirschenhofer, "How the fuel cell produces power," *IEEE Aerospace and Electronics Systems Magazine*, Nov. 1992, vol. 7 No. 11, pp. 24 –25.
- [10] Lu, Cheng-y, Alkasab. "Manual of phosphoric acid fuel cell plant cost model and computer program," [microform NAS 1.26:174720], Prepared for National Aeronautics and Space Administration, Lewis Research Center under grant NCC 3-17 for U.S. Department of Energy Technology Center.
- [11] G.J. Leng, J. Martin, "Distributed photovoltaic demand side generation: an economic evaluation for electric utilities," *Conference Record of the 24th IEEE*

Photovoltaic Specialists Conference on Photovoltaic Energy Conversion, 1994, vol.1, pp. 801-804.

[12] H. Hhatib, “Financial and economic evaluation of projects with special reference to the electrical power industry,” *Power Engineering Journal*, vol. 10, No.1, February 1996, pp. 42-54.

[13] S.G. Abens, G. Steinfeld, “Direct carbonate fuel cell power plant operating with logistic fuels,” *Proceedings of the 32nd Intersociety Energy Conversion Engineering Conference*, 1997, vol. 2, pp. 851 –856.

[14] H. Ide, T. Yoshida, H. Ueda, N. Horiuchi, “Natural gas reformed fuel cell power generation systems – a comparison of three system efficiencies,” *Proceedings of the 24th Intersociety Energy Conversion Engineering Conference*, 1989, vol. 3 pp. 1517-1522.

[15] H.K. Wang, C.K. Lee, “Application of energy audit in building and a case study,” *IEE Conference, Hongkong*, 1993.

[16] J.H. Hirschenhofer, D.B. Staffer, R.R. Engleman, M.G. Klett, Fuel Cell Hand Book, Fourth Edition, November 1998, Parsons Corporation for U.S. Department of Energy, Office of Fossil Energy.

[17] Gas Research Institute, Chicago, Illinois, “Distributed Generation Forum – Year 2000 publications”