

PSERC 98-19

# “Energy Auctions and Market Power: An Experimental Examination”

Ray D. Zimmerman  
John C. Bernard  
Robert J. Thomas  
William Schulze

Copyright 1999 IEEE. Published in the Proceedings of the Hawaii International Conference On System Sciences, January 5-8, 1999, Maui, Hawaii.

Personal use of this material is permitted. However, permission to reprint/republish this material for advertising or promotional purposes or for creating new collective works for resale or redistribution to servers or lists, or to reuse any copyrighted component of this work in other works, must be obtained from the IEEE. Contact: Manager, Copyrights and Permissions/IEEE Service Center/445 Hoes Lane/P.O. Box 1331/Piscataway, NJ 08855-1331, USA. Telephone: + Intl. 908-562-3966.

# Energy Auctions and Market Power: An Experimental Examination

Ray D. Zimmerman  
[rz10@cornell.edu](mailto:rz10@cornell.edu)

John C. Bernard  
[jcb9@cornell.edu](mailto:jcb9@cornell.edu)

Robert J. Thomas  
[rjt1@cornell.edu](mailto:rjt1@cornell.edu)

William Schulze  
[wds3@cornell.edu](mailto:wds3@cornell.edu)

Cornell University, Ithaca, NY 14853

## Abstract

*Testing auction mechanisms experimentally in a controlled environment provides an inexpensive means for evaluating their relative merits. The first part of this paper focuses on the comparison three different auctions with regard to market efficiency and pricing, given scenarios with two, four, and six competitors. Though the uniform price last accepted offer auction was superior overall, the number of competitors proved to be a more significant factor in determining auction performance. Significant exploitation of market power was observed in the duopoly case. The second part of the paper focuses on a transmission network with six sellers in which network constraints give rise to market power opportunities. Experimental evidence based on tests with student and expert subjects show exploitation of this strategic advantage. Several other scenarios are described in which the transmission network creates market power.*

## 1 Introduction

This paper reports on research being conducted by a combination of economists and electrical engineers at Cornell University who are examining potential auction institutions for restructured markets for electric power. As it is a report on developing results and analysis, the discussion remains general throughout. The research follows two related but independent strands. The first looks at the performance of various alternative auction mechanisms under different market sizes. The setting is a single sided auction with multiple units being offered and a vertical, multiple unit demand. This was conducted in the absence of a network, the equivalent of a system where transmission of electric power is lossless and costless.<sup>1</sup>

The second research strand investigates a realistic network environment using a single auction institution. This smart market experimental platform has the added benefit of being web based. One group size has been

studied, with the group containing a subset operating in a load pocket enabling simultaneous analysis of different market situations. Analysis of the market effects of load pockets is of major importance, especially in the U.S. northeast. Three pilots have been conducted in this framework, and the most interesting aspects of our findings are recorded here.<sup>2</sup>

Both parts of the research were conducted using experimental methods. By constructing these situations in a laboratory setting, we were able to control extraneous variables that complicate real world situations. Further, using experimental methods allowed us to compare prices from the auction with optimal prices and to determine actual achieved efficiencies. The importance of these abilities can be seen by imagining the expenses and difficulties in implementing an untested system on a wide scale and then discovering problems. By that stage, a substantial portion of the information necessary for analysis would be private and the mere extent of a problem even difficult to gauge. As an example of the importance of such experimental studies, consider the FCC's use of such methods during their design process for the spectrum auctions (see for instance the Fall 1997 Special Issue of the *Journal of Economics and Management Strategy*).

In our research, recruited student subjects participated in computerized experiments under controlled conditions in Cornell's Laboratory of Experimental Economics and Decision Research. Students were paid their earnings in cash at the conclusion of experiments with an additional \$5 for participation.

As noted above, the primary factors for analysis in both parts of the research were efficiency and pricing. The potential for owners of electric generators to achieve market power was a major focus as well. Secondary concerns in the first set of experiments that are currently being analyzed include a comparison of the induced cost curves and the actual offer curves, and evidence of strategic supply reduction.

---

<sup>1</sup> This first strand is from John Bernard's dissertation research. Auction software was designed and developed by Bernard, built from a generic frame supplied by the University of Arizona. Comments and questions on this section can be directed to him at [jcb9@cornell.edu](mailto:jcb9@cornell.edu).

---

<sup>2</sup> Software for this strand was developed by Ray Zimmerman. Comments and questions can be directed to him at [rz10@cornell.edu](mailto:rz10@cornell.edu).

The next two sections discuss the current state of our findings in these areas. A third section discusses several additional scenarios encountered which relate to market power opportunities. The final section gives an overview of some of the general conclusions observable at this point.

## 2 Analysis of Different Auction Mechanisms in a Non-Network Framework

This section presents the design of the first set of auction experiments and the early results. While the experiments detailed here were conducted for analysis of a wholesale market for electric power, unlike the experiments in the following section, no underlying network or transmission grid was included. This analysis, rather, presents a best case for the performance of three different auction mechanisms under three different market sizes in a setting with vertical demand.

### *Auction Selection*

Many factors went into the selection of the auction mechanisms for testing. The last accepted offer (LAO) version of the uniform price auction was selected because of its common inclusion in proposals for auction markets for wholesale electric power in states such as New York. The first rejected offer (FRO) uniform price auction was selected because of its superior theoretical properties in the single unit case. However, as stressed by Ausubel and Cramton (1996), these favorable properties do not carry over into the relevant case of multiple units. The third auction thus chosen for analysis was the multiple unit Vickrey (MUV) auction. This mechanism, alluded to briefly in Vickrey (1961), in theory should be incentive compatible with subjects submitting their true costs and capacities. Despite the length of time since its proposal, only limited experimental testing has been conducted on this mechanism. A notable example is Kagel and Levin (1997). Their effort differs from ours; they had individual subjects participating in auctions with computerized bidders.

### *Experiment Design and Subjects*

Group sizes of 2, 4, and 6 subjects were investigated. Six was selected as a group size in the hopes of creating a relatively competitive situation while the duopoly scenario was included to see the potential for, and effects of, market power. Groups of four were added to the analysis as perhaps the most realistic for a wholesale market for electric power. Given the spatial and other limits to transmitting electric power, it is likely that many market areas would contain no more than four competitors.

To give subjects in the different sized groups the opportunity to earn within the same range of money without altering the parameter setup of the experiments, three exchange rates were used with more favorable rates going to larger groups. To keep earnings reasonable, all auctions were run with a reservation price of sixty cents. This allowed us to announce a range of potential earnings, \$15 to \$35, to students during recruitment.

Cost parameters were selected to mimic the three typical levels of costs for electric power generation: base load, mid-level, and peaking. Each subject had one generator on each cost level and a total possible output capacity of five units of power. Total capacity was divided such that each subject had two “high” capacity generators (able to generate a maximum of two units) and one “low” capacity generator (capable of only a single unit). Demand was perfectly inelastic and set at one half the total capacity in the market. Demand was therefore 5, 10, and 15, for the groups of 2, 4, and 6, respectively. The cost and demand structure for the groups of 2 experiments can be seen in Figure 1. Note that the shape of the supply curve remains the same in the other group sizes, only the scale changes.

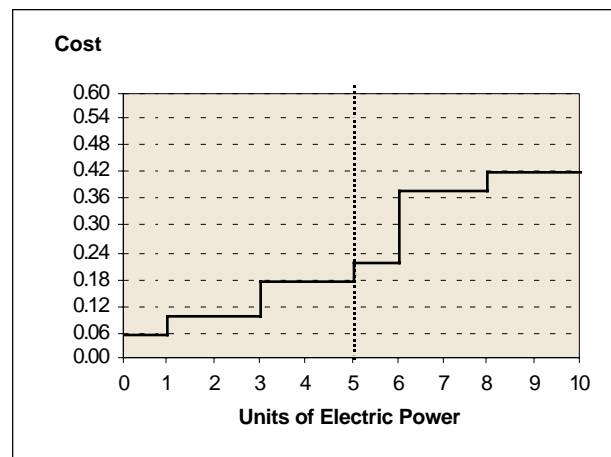

**Figure 1** Electric Power Cost Curve: Groups of Two

While the parameters were the same for all the various auction types, the same cannot be said of the resultant optimal final prices. Optimal final prices were considered as those that would result if all participants in the auction offered their full capacity at its cost. From Figure 1 again, it can be seen that the optimal price for the FRO auction would be 22 cents, while for the LAO a price anywhere from 18 to 22 cents could be considered optimal. For these two auctions, the optimal prices remained constant regardless of group size. With the nature of the pricing rules for the MUV auction, however, prices increased rapidly with smaller groups. Due to this, the optimal final price for groups of two

was 36.4 cents and for groups of four it was 28.4 cents. Only for groups of six does the MUV have an optimal price of 22 cents. The relatively inflated level of these prices suggested that the MUV auction would start with an inherent disadvantage. Indeed, it has long been a concern to many that the MUV auction would be too expensive to carry out in practice.

Subjects recruited for the experiments were undergraduate business students at Cornell University. The majority of the students were freshman and sophomores who had taken, or were currently enrolled in, introductory courses in both micro and macro economics. Few of the students had participated previously in an economic experiment and were not allowed to participate more than once. Students were told the experiments would not take more than an hour and a half. Subjects in groups finishing early were asked to wait patiently for everyone to be done so as not to disturb others and maintain group anonymity.

### Information

Subjects knew the basic information, including the reservation price and how many periods the experiment would last. They knew that the demand and everyone's costs and capacities would remain unchanged throughout the experiment. While demand was known to all, cost and capacity information was private. In addition, no information was given as to the specific distribution of the costs. Subjects were merely informed that others in their group had costs similar, possibly identical, to theirs for each of the three generators. It was common knowledge that everyone had the same total capacity, but subjects did not know whether the low capacity generator of a competitor was their low, medium, or high cost unit.

While subjects knew the size of their group, they did not know which of the others in the room were in their group. Seating patterns in the room were carefully arranged to keep group members separated at seemingly random intervals and to never have more than two people seated next to one another with different cost structures.

Offers also remained private throughout the experiments. Only the final price (or prices for the MUV) was reported to the subjects after each auction. Subjects knew how much they sold but not how much any of the others in their group sold. While this amount is obviously easy to deduce in the groups of two, there were instances where not enough supply was offered to meet demand. These instances were not reported to the subjects.

### Price and Efficiency Findings

An assessment of the average final prices over the last 25 periods of the experiments reveals group size as a much greater determining factor than auction type. Only in the groups of four did auction type make a significant difference, with the LAO having a lower average final price. As can be seen graphically in Figure 2, prices became progressively higher with smaller group sizes. In fact, in the experiments with groups of two prices were nearly twice as high as with the groups of six. Even in the groups of six, though, none of the auction mechanisms yielded prices at their optimal levels. Evidence does show prices were headed downward, suggesting experiments with more periods may be needed to find the true equilibrium.

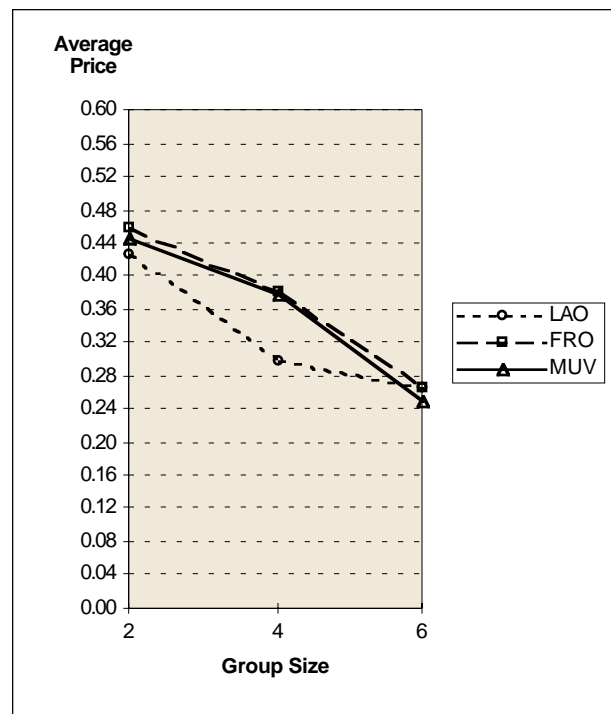

**Figure 2** Auction Comparison: Group Size vs. Price Last 25 Periods

Given the higher level of optimal prices for the MUV in both the groups of 2 and 4, it is surprising to see no significant difference between it and the uniform price auctions in the groups of two and none between it and the FRO in the groups of 4. While the MUV average prices were still above the optimum prices, this deviation was much less than the deviation in the other auctions, particularly the FRO. It would be important to determine if this was due to the favorable strategic properties of the MUV. It may be that the auction would not be as expensive as some have postulated.

Examining only average final prices over many sessions hides some of the interesting variations in the experiments. Looking at individual sessions, there was a noticeable amount of heterogeneity. This was true for the groups of 2 experiments. In many of these sessions, groups were at the sixty cent reservation price and at 100% efficiency over the majority of the last 25 periods. Groups that failed to reach the reservation price tended to have final prices in the range of the high cost generators. Beyond that point, subjects in these situations appeared determined to sell from their high cost generators, even if for only what would be a one or two cent profit. The extent of group differences was most evident in the groups of four though. Although group behavior began to converge in the later periods, in the early periods price results anywhere from the optimal level to the reservation price were observed.

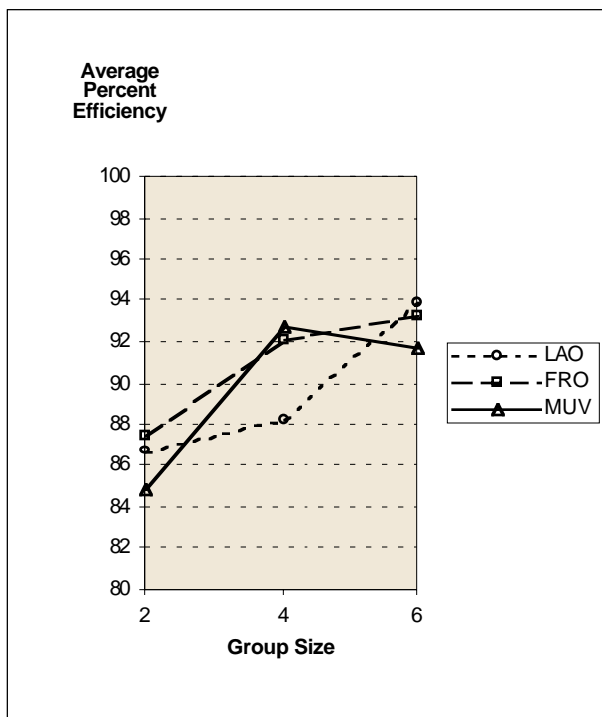

**Figure 3** Auction Comparison: Group Size vs. Efficiency Last 25 Periods

Efficiency levels are also displayed in graphical form in Figure 3. As noted by Ledyard, Porter, and Rangel (1997), care needs to be taken in using and analyzing efficiency measures. Here, the design of the cost and capacity parameters had important implications for the measurement of efficiency. For instance, the set of possible efficiency values was not continuous. The possible cost realizations imposed by the parameters increased by 4 cent intervals as production became less efficient. Group size had an even more important and noticeable effect on possible efficiency values. Specifically, the

smaller the group, the more rapid the decline in efficiency values as more costly units are produced to meet demand. Thus, participants in the groups of six actually needed to make more production errors than those in the groups of two to get the same value (consider the second highest possible efficiency in the groups of six was 0.9789, compared with 0.9394 in the groups of two). This means efficiency values are not directly comparable across group sizes.

Comparing efficiency across auction types does not reveal any superior performer, as the auction achieving the highest efficiency is different in each of the three group sizes. The FRO did perform surprisingly well, but with its efficiencies unlikely to be significantly different from the highest level reached with any of the group sizes. The poor efficiencies from the MUV may relate to the tendency for subjects to enter offers under their costs. In the worst efficiency observed, the MUV group of 2 experiments, at the optimal average price 8 of the 10 units possible could be sold for a profit. Such potential did not exist in any other auction. Other hypotheses about this low efficiency are still being discussed.

On the whole, efficiencies were lower than we hypothesized. While many groups were able to achieve and maintain 100% efficiency, many continued to exhibit low efficiencies even after sixty or seventy periods of experience with identical conditions. Even after many rounds, some subjects persisted in offering units from a higher cost generator at a price less than from a lower cost generator. In the network experiments to be discussed in the next section, subjects were not permitted to enter higher cost blocks of power for less than any lower cost blocks. Such a restriction here would have increased efficiencies in some instances.

#### *Comparison of Offer and Cost Curves / Evidence of Supply Reduction*

A secondary issue of concern was how well the auction mechanisms did at getting subjects to reveal their true costs and capacities. The two uniform price auctions performed relatively closely in terms of cost revelation and, as expected, offers in the LAO tended to be slightly higher than those from the FRO. Also as expected, offers from the uniform price auctions tended to be higher in the smaller groups.

Cost revelation was much different in the case of the MUV however; actual cost and offer curves closely overlapped one another. For low cost units that subjects learned should always be sold, offers sometimes even fell below cost. This behavior was not seen in either of the other auctions. The promising nature of this result, though, must be contrasted with the lower

efficiency discussed above. Further exploration is progressing here.

Supply reduction was evident in all auctions and in all group sizes. It is questionable, however, if this was for any strategic reason. Given the information about cost and demand structure given to subjects, it should have been apparent to them that not all their capacity could be sold. This would certainly have been reinforced after even just the first few periods of the experiments. For all auctions, supply revelation was highest in the groups of two. In fact, percent of capacity revealed tended to decrease with iteration number for all auction types.

### 3 A Test of Market Power Arising from Network Constraints

As demonstrated above, market power increases as sellers own a larger fraction of the capacity available for serving demand. In an electric power grid, the supply and demand are dispersed throughout the system. Each generator and each load lie at a specific network location. Due to the constraints imposed by the need to operate the transmission grid reliably and securely, it may not always be possible to transfer power from an arbitrary generating station to any given load. This implies that the capacity available to serve a specific load may be a subset of the total generation capacity in the system and that market power may be present if a small number of sellers own a large fraction of this subset of generation. The market is partitioned into smaller market islands by the limitations on transmission imposed by the network. If areas *A* and *B* of a transmission grid are isolated by transmission constraint, then generator *A* in area *A* cannot compete with generator *B* in area *B* to serve the load in area *B*. Likewise, generator *B* cannot compete with generator *A* to serve load in area *A*. The owner of a generation facility may have market power if they own a significant percentage of capacity in an isolated area even if they own only a small fraction of the total generation in the system.

These transmission limits may be simple and relatively constant thermal limits on the lines or they may arise indirectly from voltage or stability limits. In the latter case, the constraints may be very sensitive to VAR (reactive power) injections and other operating conditions. Therefore, market power could also arise from one's ability to manipulate the operating condition of the network in order to partition the markets to one's own advantage. For example, consider a network with a key transmission line connecting bus 1 in area *A* to bus 2 in area *B*. And suppose that the amount of power which can be transferred from *A* to *B* (while satisfying voltage limits) is highly dependent on the VAR injection

at bus 2. It may be possible for a generator at bus 2 to isolate itself from competition from area *A* by withholding VAR capacity.

In summary, there are at least two ways in which the transmission network can create market power opportunities in load pockets. First, transmission constraints, arising from line limits, voltage limits, or stability limits, may partition the market into islands which may create the type of market power described above. Second, one may exploit one's position in the network to strategically partition the market to one's own advantage. The simple auctions tested above do not take into account transmission system constraints. The dispatch schedule produced by such simple auctions would often lead to infeasible operating conditions if employed in a constrained network (see for example, Hogan, 1992). The answer to this problem, of course, is use of a smart market which employs an auction where offers are adjusted for nodal pricing through transmission charges determined by an optimal power flow (McCabe, Rassenti, and Smith, 1991).

We have conducted three experiments using experienced subjects (who had participated in the LAO sessions described above) in a smart market network environment. These experiments used a LAO auction with prices and offers adjusted for location in the network via an OPF (optimal power flow).

#### *The Smart Market*

The smart market is needed to account for the operational constraints imposed by the physical transmission network. In this context, the sellers and the buyer's demands are connected by a transmission network which must be operated at all times in a manner consistent with the laws of physics governing the flow of electricity. The operation of the network is also constrained by the physical limitations of the equipment used to generate and transmit the power. This results in two phenomena which may affect the auction: (1) *transmission losses* and (2) *congestion*.

A small percentage of the energy produced by the generators is dissipated by the transmission lines. The amount of power lost depends on the flow in the line and the length of the line, among other things. *Transmission loss implies that the total amount of power the buyer must purchase is slightly greater than the total demand and the exact amount is dependent on where the power is produced.*

There are limits on the amount of electric power that can be transmitted from any given location to any other location. Some of the limits are simple line capacity limits and others are more subtle system constraints arising from voltage or stability limits. *Congestion*

occurs when one or more of these network limits is reached. *Congestion implies that some inexpensive generation may be unusable due to its location, making it necessary to utilize a more expensive unit in different location.*

The effects of losses and transmission system constraints are handled by adjusting all offers and prices by a location specific *transmission charge* which represents the cost of transporting the electricity from the respective generating station to some arbitrary reference location. There is a two part transmission charge associated with each line which is divided up between the various generators based on their individual contributions to the flow in the line. The per-line transmission charges can be explained as follows. The value of the power dissipated by a transmission line is the loss component of the transmission charge for that line. The congestion component of the transmission charge is precisely the charge necessary to discourage overuse of the line. If there is no congestion, this component is zero. It is important to note that the transmission charges are dependent on the flow in each transmission line as well as each generator's contribution to that flow and therefore cannot be computed before performing the auction. In this context, each generator receives a price which is specific to its location.

Units are chosen so as to satisfy demand in the least expensive manner while satisfying the operational constraints of the transmission system. This is done by an optimal power flow program which computes the appropriate transmission charges for each generating station. The units selected by the optimization program are roughly those given by the following procedure. The appropriate transmission charge is added to the price of each offer, and the offers are ordered from lowest to highest adjusted offer price. Units are included for sale, starting from the low priced units and moving toward the higher priced units, until the supply reaches the total buyer's demand plus transmission losses. The remaining, higher priced, units are excluded from sale.

The reigning price is set to the adjusted offer price of the last (most expensive) unit chosen. The price paid for each unit produced by a given generator is the *reigning price minus the corresponding transmission charge*.

### The Experiment

We conducted three experiments with our web-based experimental platform, called **POWERWEB**, which implements the smart market described above using an OPF that models a full non-linear lossy AC transmission network. These experiments utilized the six gen-

erator, 30-node network model, shown as a simplified block diagram in Figure 4.

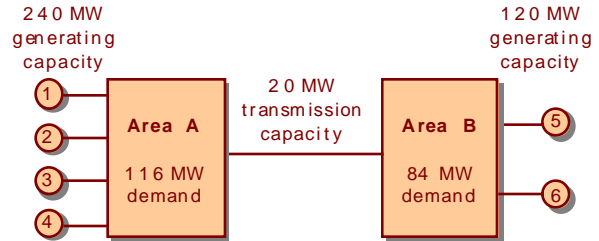

Figure 4 Transmission Network Block Diagram

Each of the six subjects in each experiment was one of six sellers in a market with a single buyer with a fixed demand. All generators had a capacity of 60 MW (megawatts) which was divided into 3 blocks, 12, 24, and 24 MW at prices of \$20, \$40, and \$50/MW-hr, respectively. All generators had identical capacity and cost structures. Each generator could generate between 12 and 60 MW of power, or could be shut down completely, in which case it incurred no costs.

The network was structured so as to create a load pocket in Area B, where generators 5 and 6 are located. The limitation on transmission capacity between areas A and B, can effectively separate the market into groups of four and two competitors, respectively. The demand levels and network constraints are such that neither generator 5 nor generator 6 can be shut down.

Figure 5 and Figure 6, respectively, show examples of the offer submission and auction result pages used by **POWERWEB**. Note that the costs in the figure are not those used in this set of experiments.

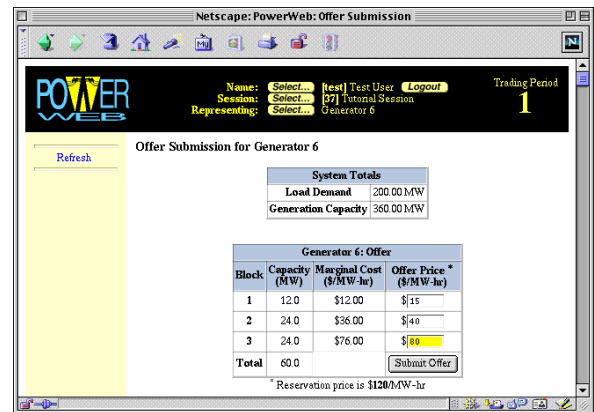

Figure 5 Offer Submission Page

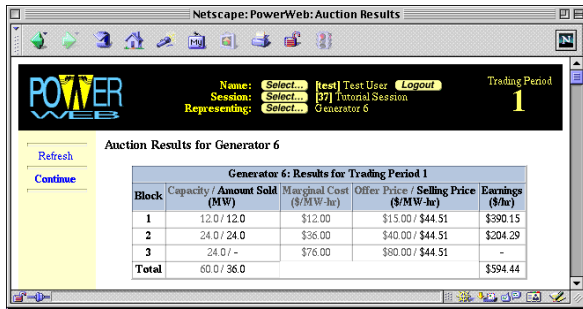

Figure 6 Auction Results Page

Each of the three sessions was run for 75 rounds, and each produced different results. Figure 7 shows the price results for a session that can be used to characterize all three sessions. In one session, the results for the prices received by the six generators remained similar to the price pattern shown in the figure prior to period 50. In other words, prices remained near the competitive level (shown by the heavy horizontal line in the figure) throughout the session. In a second session, prices were similar to those shown after trading period 50 in the figure, for the entire session. In other words, generators 5 and 6 were able to exploit their market power consistently from the initial trading periods through period 75. In the session shown in the figure, generators 5 and 6 were not able to coordinate their price offers to exploit the market power opportunities offered by the network until period 50. It appears that generator 5 (dashed/dotted line, 2<sup>nd</sup> from top) was not responsive to generator 6 (solid line, top) who attempted to raise prices early in the session.

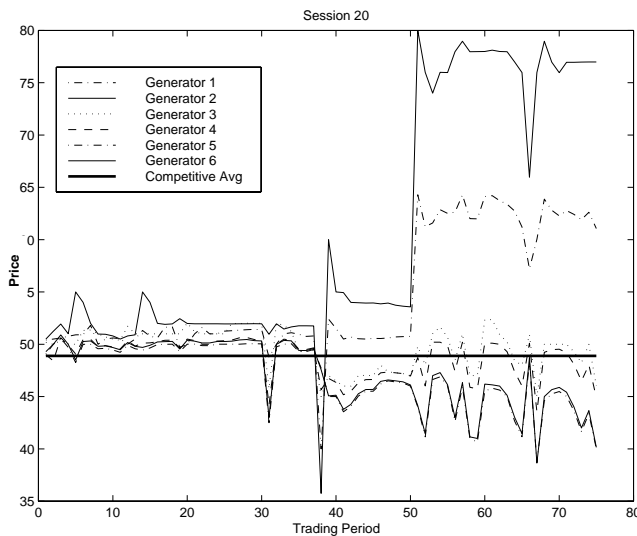

Figure 7 Nodal Prices

We draw two conclusions from these results. First, in two of the three sessions generators 5 and 6 were able to exploit the opportunity to use market power. It should be noted that the 75 trading periods used provides far less experience than actual generators will accumulate over a summer season during peak load periods when networks are likely to be constrained. Thus, it is reasonable to conclude that market power will be exercised. Second, if generators exploit market power, prices will not only be higher in load pockets, but also price volatility will increase. This implies the possibility that network stability and reliability may be jeopardized since relays have been set on the basis of stable generation patterns throughout the networks.

A nearly identical experiment with 65 trading periods was later performed using electricity traders as subjects. Once again, the market power opportunities were quickly recognized and exploited. Prices well above competitive levels were observed at generators 5 and 6 as early as the second trading period, and remained consistently high after about 25 periods. This result supports the conjecture that the behavior of expert subjects does not differ significantly from that of the more accessible student subjects.

#### 4 Other Scenarios Encountered

In addition to the partitioning of the network via simple transmission line limits, as discussed above, several other interesting scenarios relating to market power have been observed with **POWERWEB** using variations of the six generator, 30-bus network used in the experiment above. Figure 8 shows the one-line diagram for this system.

In this network, each of the six generators has a minimum and maximum output capacity of 12 MW and 60 MW, respectively. All transmission lines are unconstrained except those explicitly indicated.

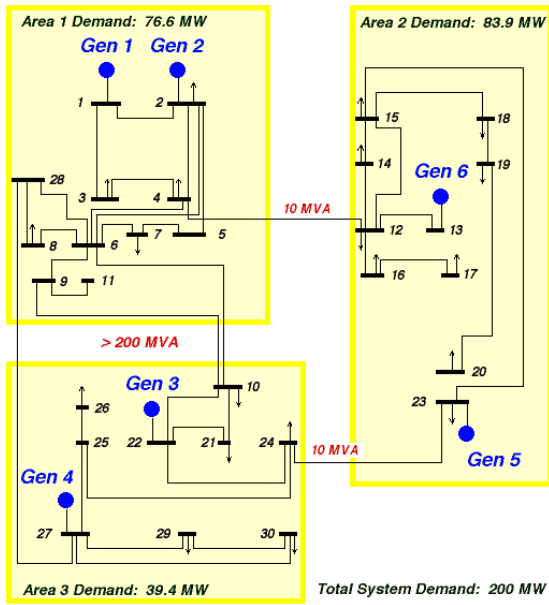

Figure 8 30-bus Network with Area 2 Isolated

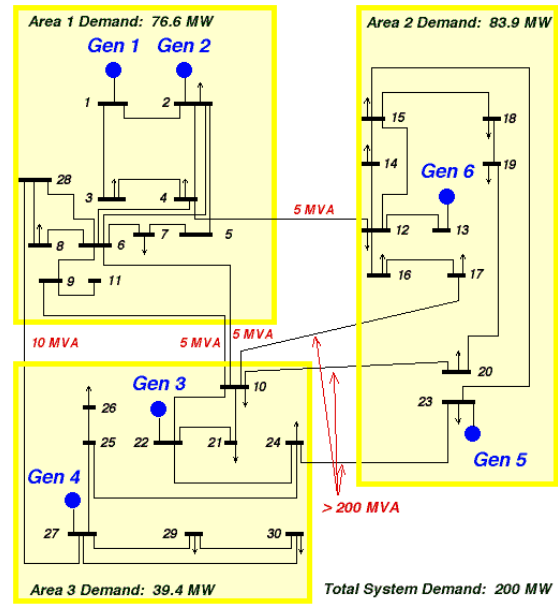

Figure 9 30-bus Network with Area 1 Isolated

#### 4.1 Price Differentials Due to Voltage Limits

Using the network shown in Figure 8, it was found that even in Area 2, at times the price at bus 13, where generator 6 is located, was significantly higher than the price for generator 5 at bus 23. This appears unusual at first, since there appear to be no transmission limits separating the two buses. However, the only way for the system to cut back on generator 6 in favor of the cheaper power from generator 5 would be to violate a voltage limit at bus 20. In this case, a voltage limit creates a limit on the transfer capacity of the network, thus partitioning the network and potentially creating market power opportunities.

#### 4.2 Cascading Market Power

Consider a variation of the same 30-bus system, shown in Figure 9, in which Area 1 is isolated by transmission line constraints.

In this scenario it is also possible for the generators in the isolated area to raise prices together far above competitive levels. It was also observed that, with generators 1 and 2 submitting extremely high offers, generator 4 was also isolated from competition and was able to inflate its offers. In a case where the network is partitioned into two (or more) areas with large differences in price between the areas, efficient operation of the grid will always ensure that the lines transmitting power from the low priced to high priced areas are operating at capacity.

In this example, generator 4 is the only generator in a position to ensure that the line from bus 27 to bus 28 is operating at capacity. All other generators cause congestion of other lines before “filling” line 27-28. This special position allows generator 4 to raise its offers almost to the level of the price in area 1 before its output is reduced. When the market power present in area 1 is exploited by raising prices, there is a cascading effect, putting generator 4 in a position to exercise market power as well.

#### 4.3 Market Power Due to Reactive Power Requirements

Even if a generator’s position in the network offers no strategic advantage with regards to supplying real power, the reactive power requirements of the system may allow it to manipulate real power prices. One scenario observed in experimental testing was a case in which the reactive power output of a specific generator, though not necessarily large, proved to be essential to

the feasible operation of the transmission system. In this scenario, the generation owner charged an exorbitant price for real power once he found out the system could not operate without his reactive power output.

## 5 Conclusions

Our collaborative work at Cornell has produced a number of preliminary conclusions relevant for restructuring of the electric power industry. First, in testing auction institutions, as Ausubel and Cramton (1996) have shown in theory, the uniform price first rejected offer auction fails to be incentive compatible in practice when sellers own multiple units. Somewhat surprisingly, a uniform price last accepted offer auction performs slightly better under the same cost and demand conditions. Since this is the institution most often proposed or used to date in electric power markets, this is good news. The multi-unit Vickrey auction is theoretically incentive compatible but treats generators as discriminating monopolists and, so, is likely to be expensive to implement. This auction proved less expensive to implement than might be imagined under our quasi-realistic cost structure, but did not produce average prices lower than the last accepted offer auction. Overall, the number of firms competing to supply the fixed demand proved to be a much more important determinant of price than the type of auction employed. Prices were near competitive levels with six sellers but doubled with two competitors. Our network experiments support these results. In a complex environment, with six generators, two of whom are located in a load pocket, prices approached duopoly levels inside the load pocket. In addition, nodal prices throughout the network were much more volatile under conditions where market power was exercised. This volatility could threaten system stability given current practices. These results have obvious implications for

the sale of generation assets in areas like the U.S. northeast where network constraints may give rise to areas of potential market power.

## References

1. Ausubel, L.M., and P.C. Cramton, 1996. "Demand Reduction and Inefficiency in Multi-Unit Auctions." University of Maryland Working Paper No. 96-07.
2. Bernard, J., W. Schulze, and T. Mount, 1997. "Auction Mechanisms for a Competitive Electric Power Market", paper presented at the American Agricultural Economics Association Summer Meetings, July 1997, Toronto, Can.
3. Hogan, William. 1992. "Contract Networks for Electric Power Transmission." *Journal of Regulatory Economics*, 4: 211-242.
4. Kagel, J., and D. Levin, 1997. "Independent Private Value Multi-Unit Demand Auctions: An Experiment Comparing Uniform Price and Vickrey Auctions." Mimeographed.
5. Ledyard, J., D. Porter, and A. Rangel, 1997. "Experiments Testing Multiobject Allocation Mechanisms." *Journal of Economics and Management Strategy*, 6:639-675.
6. McCabe, K. A., S. J. Rassenti, and V. L. Smith, 1991. "Designing Smart Computer Assisted Markets," in *Papers in Experimental Economics*, ed. V. L. Smith. Cambridge University Press, New York.
7. Smith, V., 1996. "Market Power and Mechanism Design for Deregulated Electricity Networks" Selected Paper presented at the Economic Science Meetings, Oct. 17-20, 1996, University of Arizona. Tucson, Arizona.
8. Vickrey, W., 1961. "Counterspeculation, Auctions, and Competitive Sealed Tenders." *Journal of Finance*, 16:8-37.
9. Zimmerman, R. D., R. J. Thomas, D. Gan, C. Murillo-Sánchez, "An Internet-Based Platform for Testing Generation Scheduling Auctions," Proceedings of the 31<sup>st</sup> HICSS Conference, Kohala Coast, Hawaii, Jan 6-9, 1998.