

A Bi-Stable Branch Outage Model for Cascading Failure Analysis

Prof. Chris DeMarco
Electrical and Computer Engineering
University of Wisconsin-Madison

© 2001 University of Wisconsin Board of Regents. All rights reserved.

A Bi-stable Branch Outage Model for Cascading Failure Analysis

- ◆ Motivation - failure of single transmission line in heavily loaded electric grid often creates overloads in parallel lines.
- ◆ Equipment protection schemes then remove from service other overloaded branches.

Critical question: does effect cascade from local phenomena to “global” failure?

Motivation & Background

- ◆ Key goal #1: efficient methods for predicting “cascading” effects, identifying scenarios that lead to large area failures.
- ◆ Extension to state of the art: seek to capture influence of network dynamics in cascading overloads, as well as role of stochastic disturbances.

Approach and Outcome

- ◆ Key “trick” - smooth approximation to mechanism of local branch failure.
- ◆ Impose special structure on global dynamics, allows tractable energy function in model w/stochastic disturbances.
- ◆ Payoff: a “phase transition” type model, identifying vulnerability to global failures.

Related Work under EPRI/ARO Complex Interactive Networks Initiative

- ◆ Vergheese and co-workers(MIT) - “Influence model.” Markov chain model for failure AT NODES, with interconnection network determining “influence” of one node failure on other nodes.

Existing Work

- ◆ Thorp and co-workers (Cornell):
refinements to importance sampling to
allow identification of sequence random
BRANCH failures leading to large area
failure.
- ◆ To date, computational challenges limit
overload calculation to algebraic steady
state threshold - no dynamics.

Overview of Approach Here

- ◆ Develop o.d.e. model for branch parameter, with bi-stable equilibria: one at operational value, one at failed value.
- ◆ Drive these dynamics with coupling term that represents loading level on branch.

Overview of Approach Here

- ◆ Argue that a class of useful models can be built with special structure:

$$\dot{\mathbf{x}} = \mathbf{A} \nabla \vartheta(\mathbf{x})$$

(deterministic case)

$$d\mathbf{x} = \mathbf{A} \nabla \vartheta(\mathbf{x}) - \frac{1}{2}(\mathbf{A} + \mathbf{A}^T)^{1/2} d\mathbf{W}_t$$

(with stochastic disturbances)

Overview of Approach Here

- ◆ Key foundation: local failure mechanism through energy storing branch element (inductance in circuit model to follow; spring constant in finite element spring/mass/damper models, others... ?)
- ◆ Branch failure associated with element admittance approaching zero.

Motivating/Illustrative Example: Linear RLC with Inductive “Fuses”

- ◆ Simple one branch example: can we capture series branch failure in structured model?

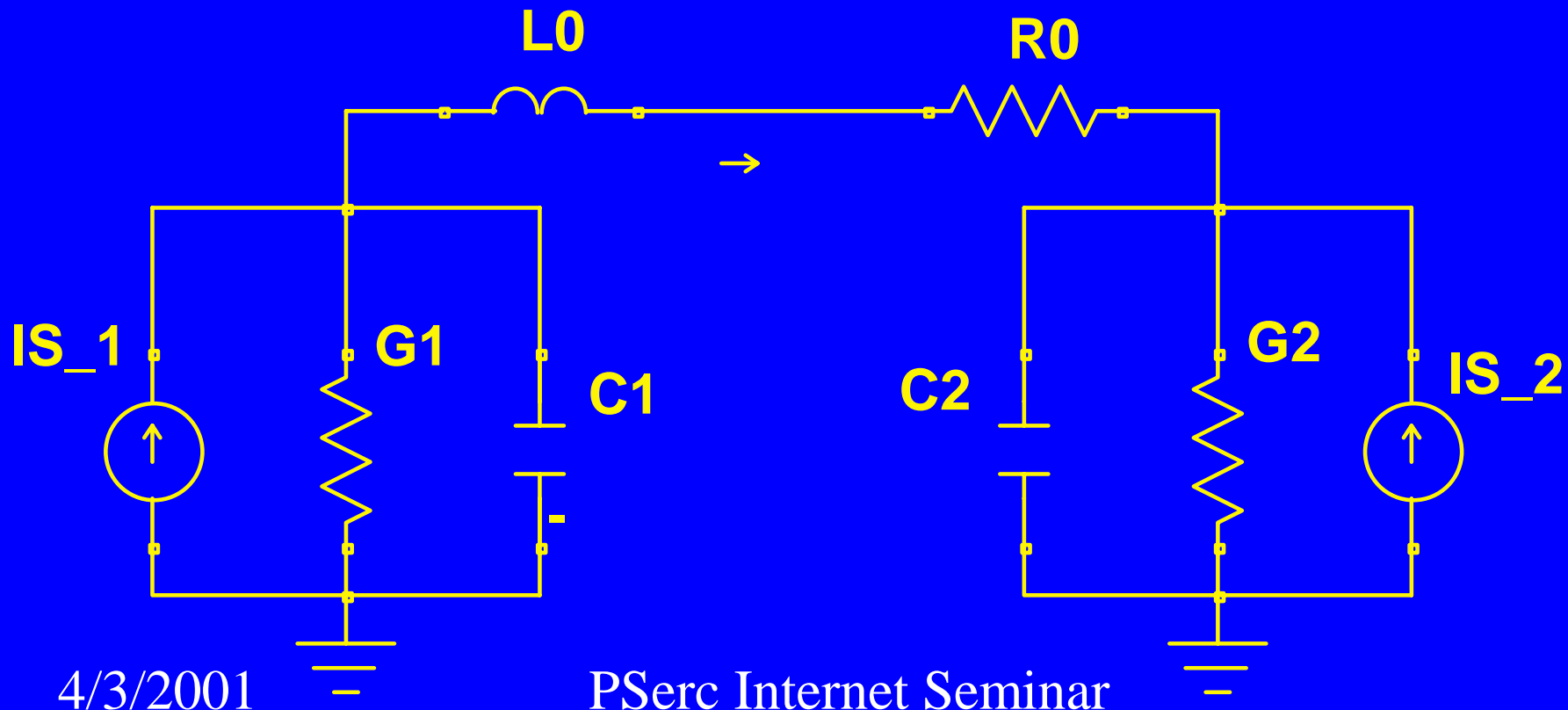

Motivating Example: Linear RLC

- ◆ Convenient states: capacitor charges, inductor flux. Resulting model

$$\begin{bmatrix} \dot{q}_1 \\ \dot{q}_2 \\ \dot{\phi}_0 \end{bmatrix} = \begin{bmatrix} -G_1 & 0 & -1 \\ 0 & -G_2 & 1 \\ 1 & -1 & -R_0 \end{bmatrix} \begin{bmatrix} q_1/C_1 \\ q_2/C_2 \\ \phi_0/L_0 \end{bmatrix} + \begin{bmatrix} i_{s,1} \\ i_{s,2} \\ 0 \end{bmatrix}$$

Motivating Example: Linear RLC

- ◆ For given $i_{s,1}$, $i_{s,2}$, let q^e 's φ^e denote equilibrium states. Define a “relative energy” potential function:

$$W_r(q_1, q_2, \varphi_0) = \frac{1}{2C_1} (q_1 - q_1^e)^2 + \frac{1}{2C_2} (q_2 - q_2^e)^2 + \frac{1}{2L_0} (\varphi_0 - \varphi_0^e)^2$$

Motivating Example: Linear RLC

◆ State equations then take form:

$$\begin{bmatrix} \dot{q}_1 \\ \dot{q}_2 \\ \dot{\phi}_0 \end{bmatrix} = \begin{bmatrix} -G_1 & 0 & -1 \\ 0 & -G_2 & 1 \\ 1 & -1 & -R_0 \end{bmatrix} \nabla_{q_1, q_2, \phi_0} W_r(q_1, q_2, \phi_0)$$

Denote as "A"

Treatment of Inductive “Fuses”

- ◆ Consider linear inductance element, letting parameter “N” represent inverse inductance; i.e., $N = 1/L_0$. Value in “normal” operation denoted N^e .

Contribution to energy becomes

$$\frac{1}{2}N\phi^2 - N^e\phi^e\phi + \frac{1}{2}N^e(\phi^e)^2$$

Treatment of Inductive “Fuses”

Observations:

$$\frac{\partial W}{\partial N} = \frac{1}{2}\phi^2 \approx \frac{(L^e)^2}{2} i^2 : \text{Branch loading indicator!}$$

$N \rightarrow 0 \Leftrightarrow L \rightarrow \infty \Leftrightarrow$ branch impedance
goes to infinity

Treatment of Inductive “Fuses”

Next - append continuous *dynamics* for N.

Key element of dN/dt driving term:
define a scalar threshold function $\Psi(N)$ to
set limit at which failure is triggered, as
shown on following slide...

Threshold function for “N” dynamics

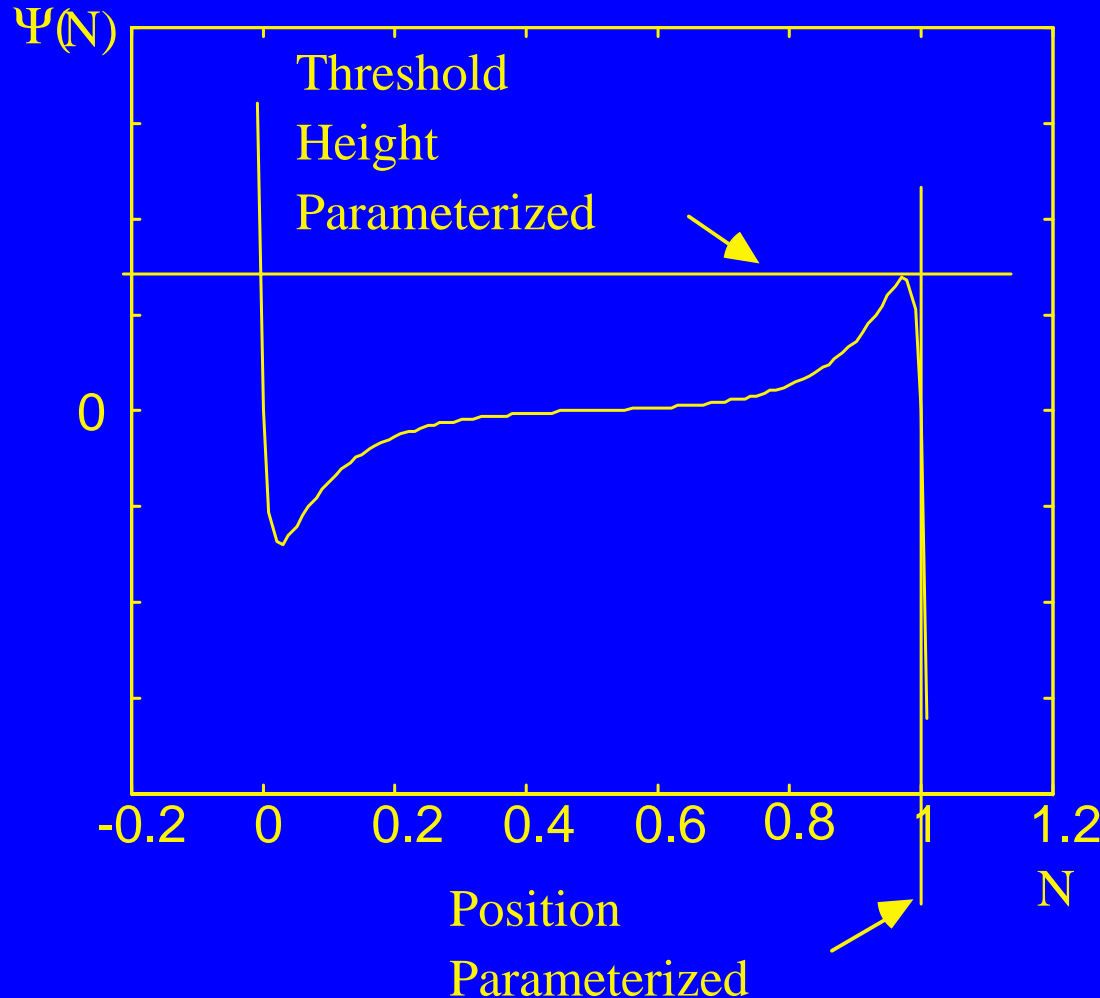

Easily constructed as sum of weighted and shifted exponentials - and hence easily integrated.

“N” Dynamics

$$\dot{N} = \frac{1}{\tau} \left\{ \Psi(N) - \frac{1}{2} \phi^2 \right\}$$

Behavior: N stable, in neighborhood of normal value N^e , for low flux; driven to neighborhood of zero when flux exceeds threshold (note no possible recovery back to N^e). Rate governed by τ .

Composite Dynamics Construction

Extend arguments of W_r to reflect additional dependence on N :

$$z = [q_1, q_2, \varphi_0, N]^T$$

$$W(z) = W_r^{\text{old}} + \int_{N^e}^N -\Psi(\eta) d\eta$$

Composite Dynamics

$$\dot{\mathbf{z}} = \mathbf{A} \nabla_{\mathbf{z}} W(\mathbf{z})$$

$$\mathbf{A} = \begin{bmatrix} -\mathbf{G}_1 & 0 & -1 & 0 \\ 0 & -\mathbf{G}_2 & 1 & 0 \\ 1 & -1 & -\mathbf{R}_0 & 0 \\ 0 & 0 & 0 & -1/\tau \end{bmatrix}$$

Composite Dynamics Properties

- ◆ A is full rank, negative semi-definite;
- ◆ $W(z(t))$ therefore non-increasing along any solution trajectory;
- ◆ Equilibria only at critical points of W ;
- ◆ Standard Lyapunov arguments reveal an equilibrium z^e is asymptotically stable $\Leftrightarrow z^e$ local minimum of $W(z)$

Properties in Stochastic Formulation

- ◆ Simple diagonal form of symmetric part of \mathbf{A} allows introduction of white noise uncorrelated in each state equation (see slide #8).
- ◆ $W(z)$ plays role of Wentzell-Freidlin's quasi-potential function (hence statistical properties such as asymptotic behavior of expected time to exit a domain become calculable...)

Time Domain Behavior - have we captured branch failure?

- ◆ Sequence of simulations to follow illustrate trajectories of our little 4 state model;
- ◆ Step input current at node 1;
- ◆ Reduce threshold function peak, to illustrate trigger of inductance branch failure.

Test Circuit

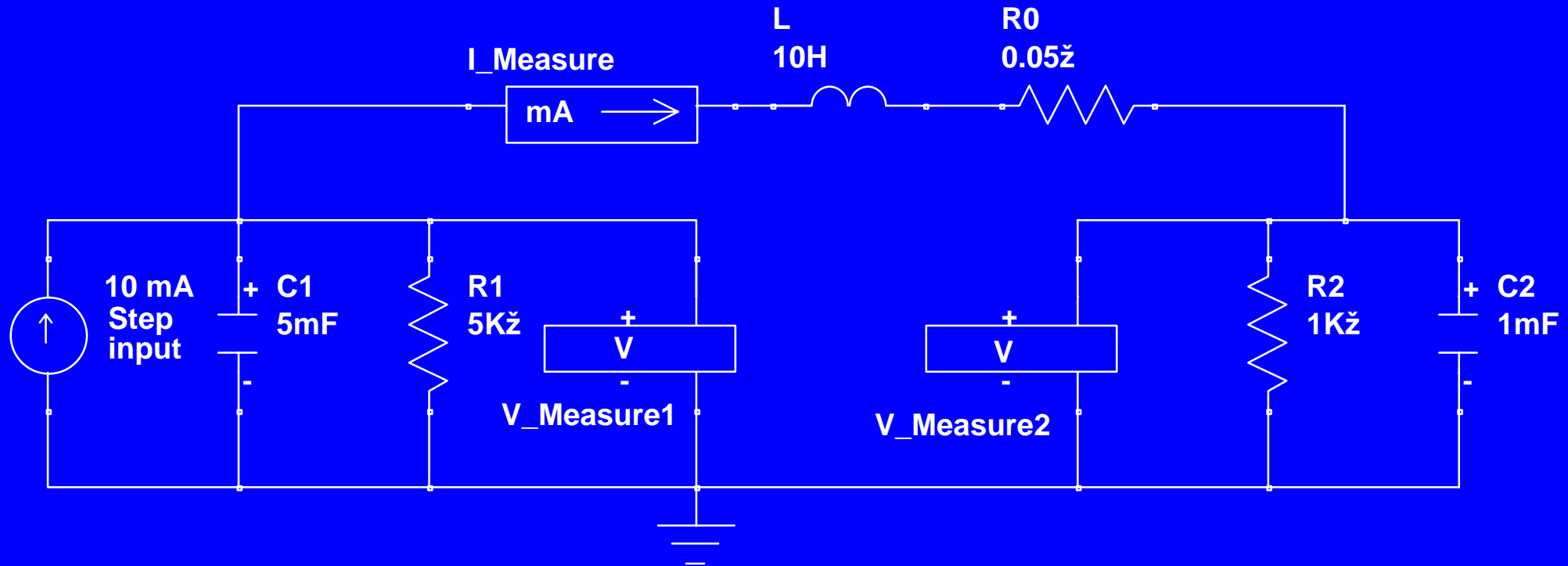

SPICE Plot-No Branch Failure

Transient Graph

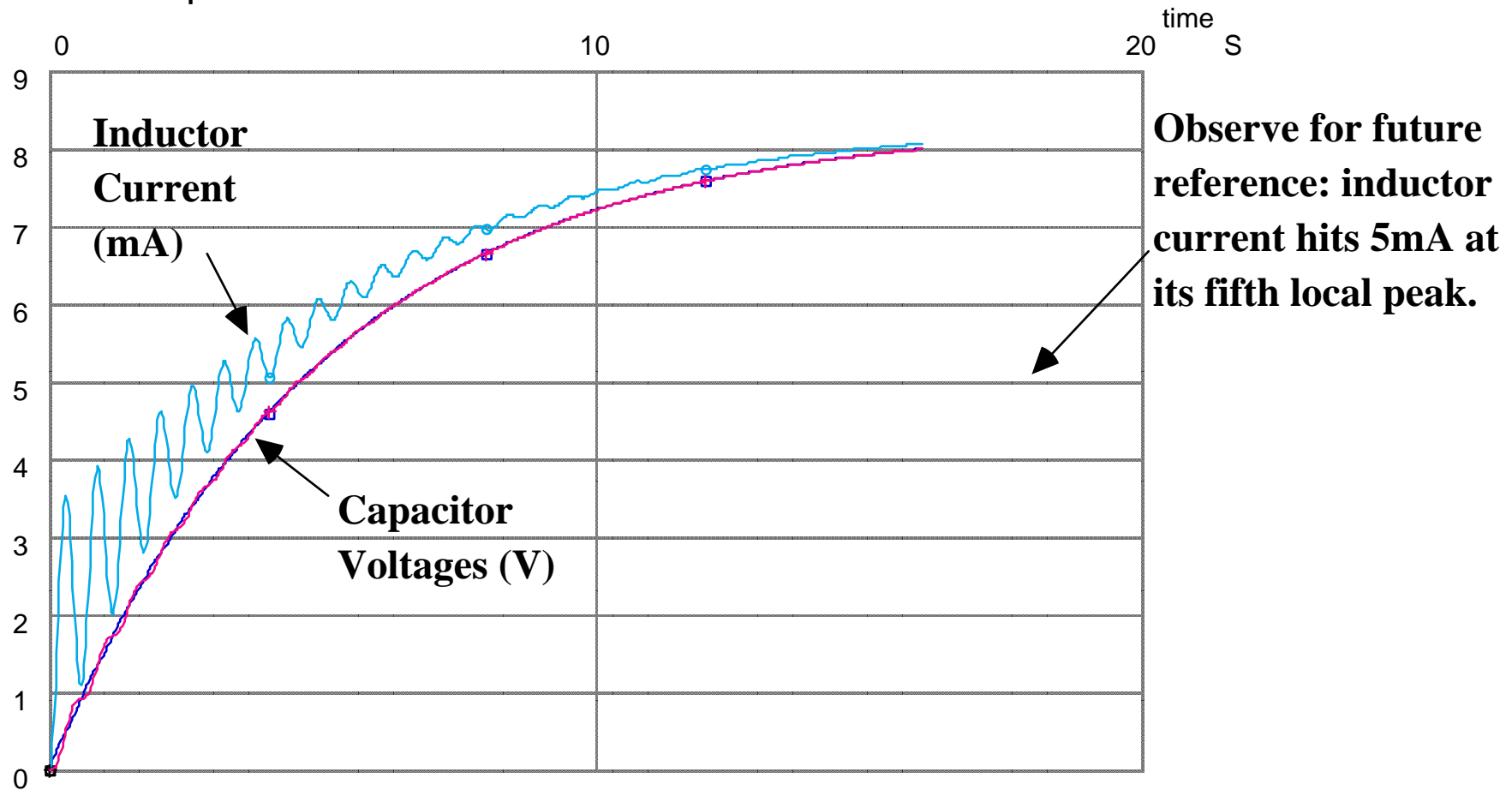

Branch Failure Threshold

- ◆ Equilibrium current after step = 8.33 mA; corresponding flux $\varphi^e = 0.0833$ Wb-turns.
- ◆ Select threshold of branch trip event to be 5 mA, or $\varphi = 0.05$ Wb-turns; threshold value for $\Psi(N)$ set at $0.5\varphi^2 = 0.00125$. From SPICE plot, expect failure just before 3 seconds (0-3 sec SPICE plot follows)

Transient Graph

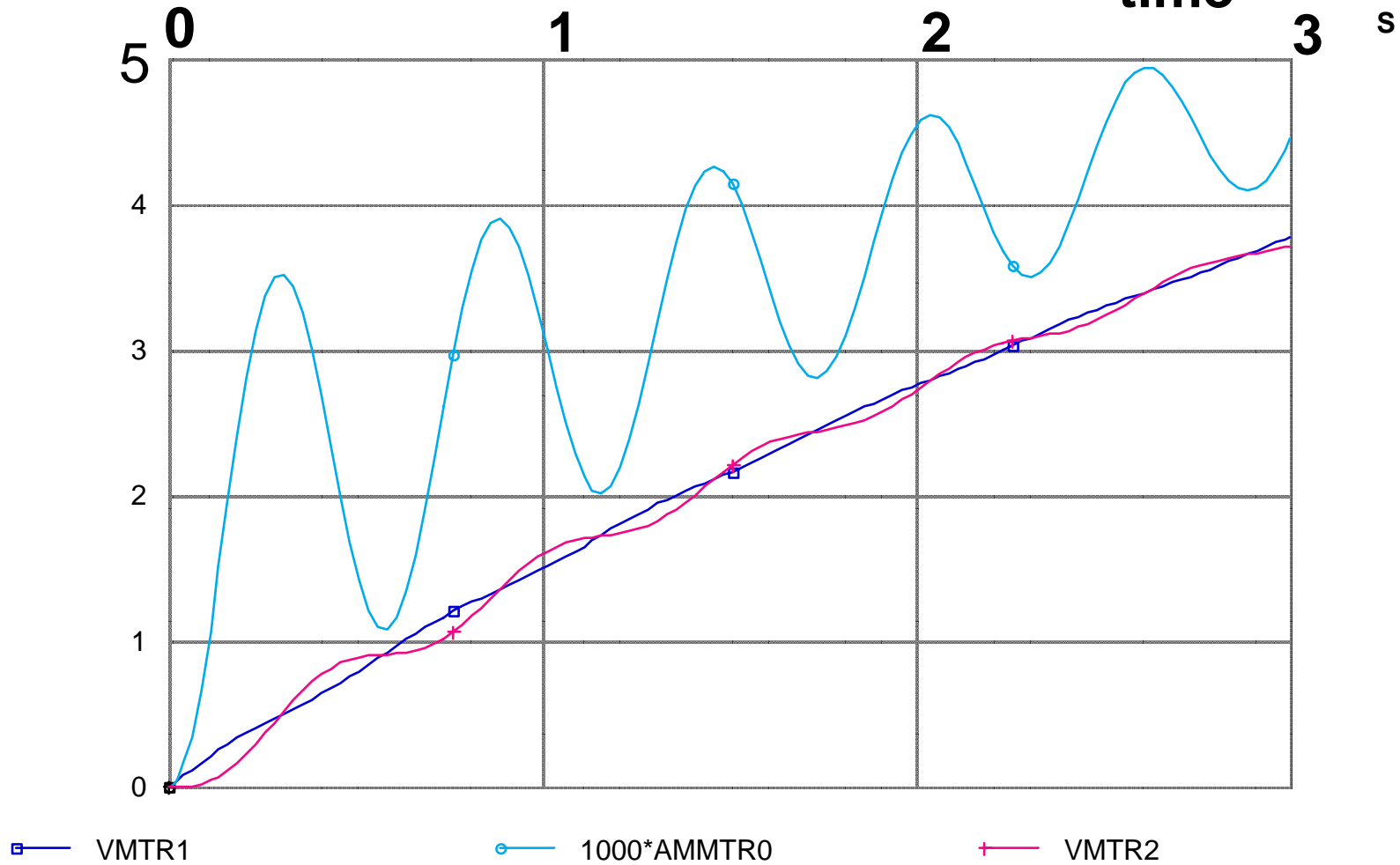

Trajectories of Branch Failure Model (MATLAB o.d.e. solver)

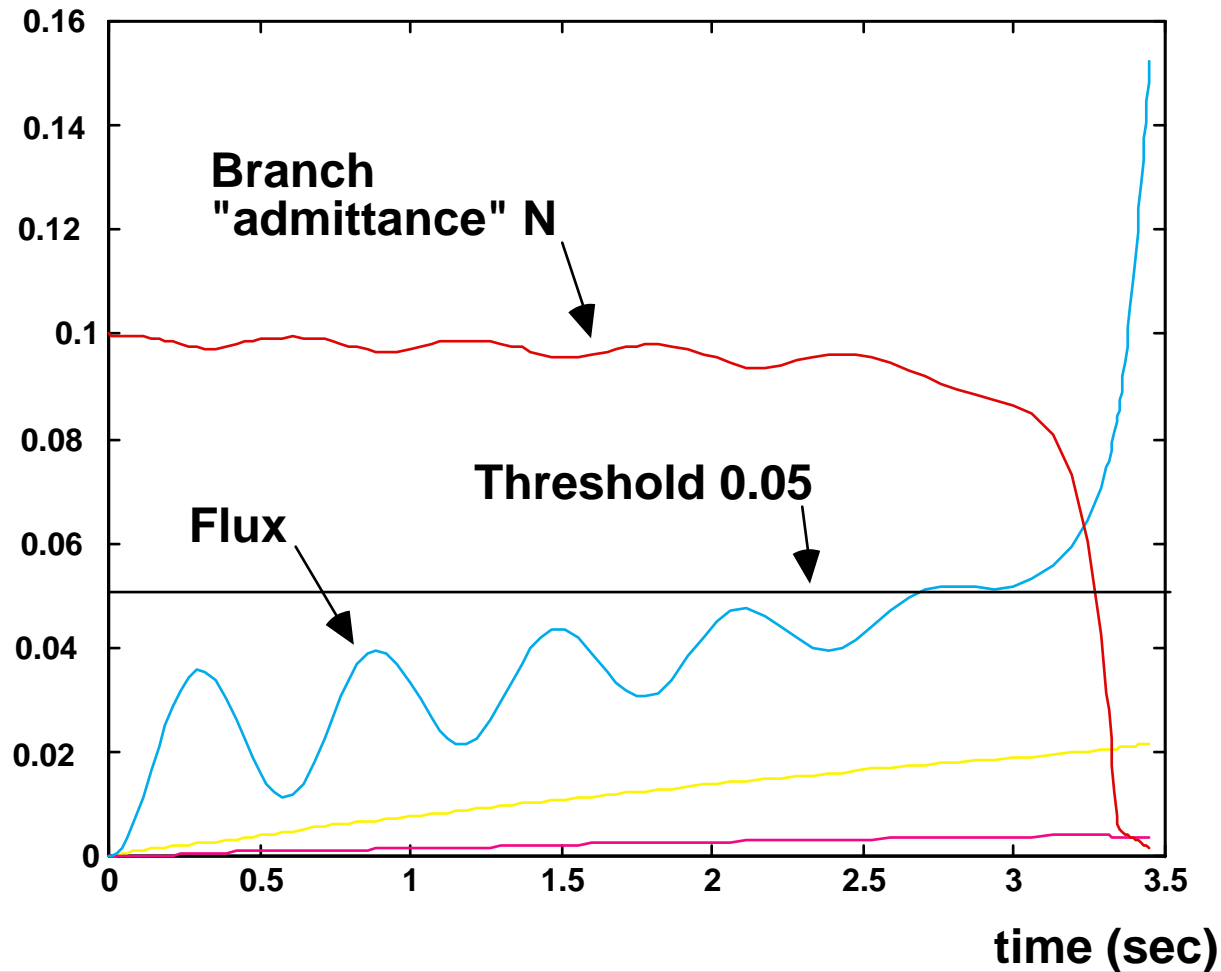

Comments/Interpretations

- ◆ Appear to have qualitative behavior correct
 - branch parameter N rapidly decays to 0 at approximately correct threshold
- ◆ In pre-failure region, parameter N “wanders” slightly with flux; this is an undesirable artifact of our model.

Comments/Interpretations

- ◆ Observation: to be friendly to numerical integration routines, slope of $\Psi(N)$ function was made gentle in this example.
- ◆ Local variation in N with flux reduced as $\Psi(N)$ slope is steeper (consider slide 17).
- ◆ We DO NOT advocate this model as a simulation tool - it stinks. Payoff is all in closed form of $W(z)$

Use of $W(z)$ Energy Function

As with traditional energy function/Lyapunov analysis, great power in having closed form function for which trajectories globally decay.

Contour plot to follow shows operational state creating one basin, failed state creates another. Saddle exit between the two corresponds to an unstable equilibrium.

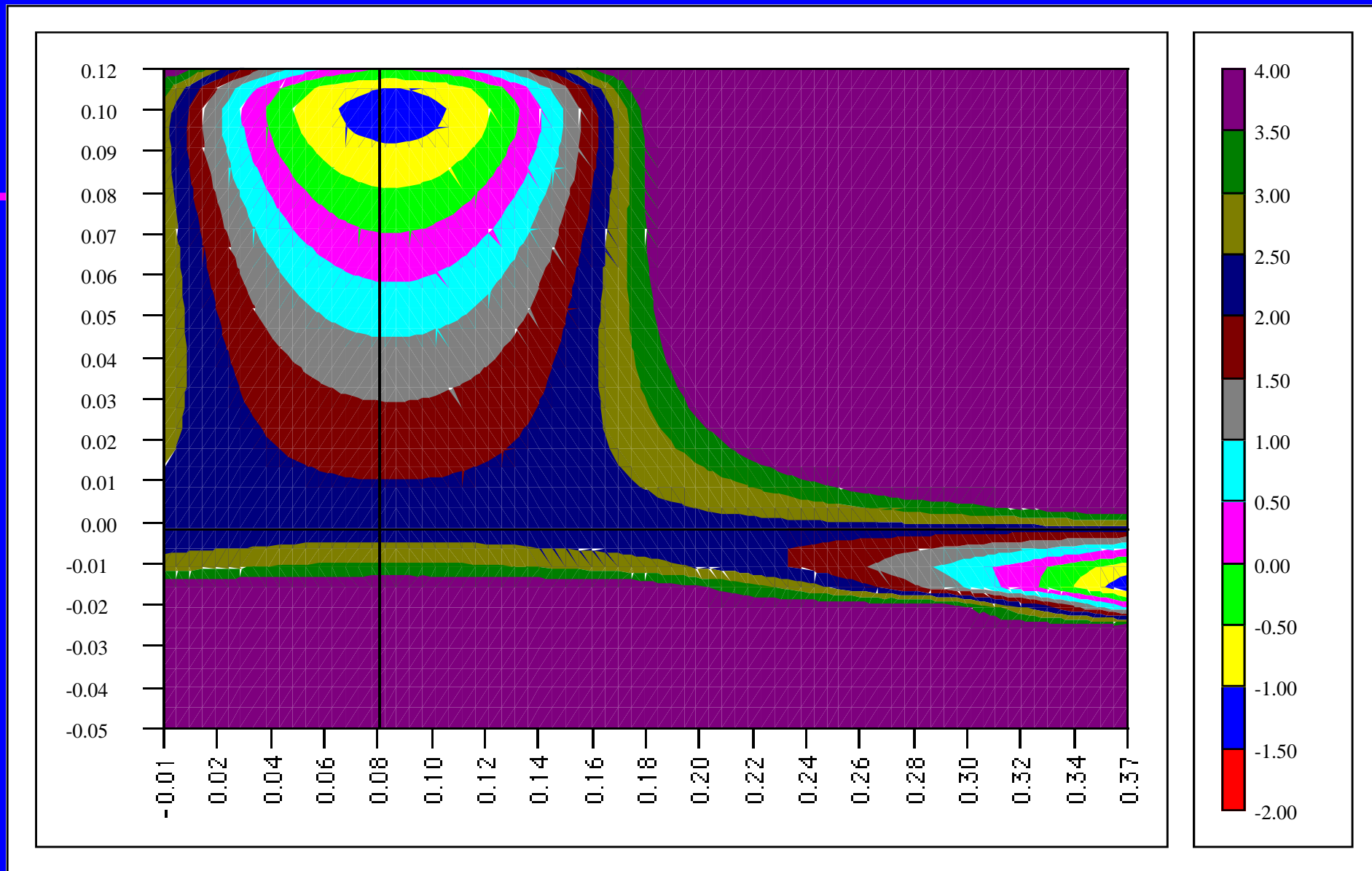

Horizontal Axis: Flux; Vertical Axis: N (inverse inductance)

4/3/2001

PSerc Internet Seminar

32

Future Work/Conclusions

- ◆ Promising avenue for introducing plausible model for branch failure, while maintaining analytically tractable structure.
- ◆ Operational configurations become locally stable energy wells., “path to instability” through saddle exits.

Future Work/Conclusions

- ◆ Test of vulnerability to global failure captured in ease of escape from wells.