

Models for Electric Transmission Property Rights

Ross Baldick
Department of Electrical and Computer Engineering
The University of Texas at Austin

May 2007

A property rights model for electric transmission is proposed. The establishment of these transmission property rights would permit the creation of financial rights that would support transmission investment and financial hedging of transmission risk. These financial rights would allow for forward trading of both energy and transmission in a unified power exchange, avoiding the division that exists in current markets between decentralized long-term energy trading and centralized long-term transmission trading. Such long-term trading could help support the financing of both generation and transmission assets. This presentation will provide a description of the proposed model for electric transmission property rights based on “border flow rights” with associated financial rights called “contracts for differences of differences.”

Copyright © 2007 Ross Baldick

Outline

1. Introduction,
2. Goals,
3. Hedging of transmission and energy prices,
4. Proposed property right,
5. Example illustrating revenue stream,
6. Example illustrating counterflow,
7. Proposed financial right,
8. Trading of financial rights,
9. Merchant construction,
10. Conclusion.

1 Introduction

1.1 Property rights for transmission

- Fundamental question is “what property right should we confer on an investor in transmission assets?”
- In this context, “property right” means the definition of a revenue stream to the investor.

1.2 Existing property rights models for transmission investment and drawbacks

1.2.1 Cost of service (COS)

- Regulated return on equity, as determined by Public Utility Commission, on ratebased assets independent of performance.
- Poor incentive properties and limited scope for merchant transmission.

1.2.2 Financial Transmission Rights (FTRs)

- Payment based on Locational Marginal Price (LMP) difference for the nominated FTR that is made possible by asset.
- Requires careful nomination of FTR and requires ISO to issue FTRs to ensure ISO revenue adequacy.

1.2.3 Performance-Based Rates (PBRs)

- Compensation that decreases with increasing congestion cost.
- Difficulty in setting baseline for payment and limited scope for merchant transmission.

2 Goals

- Define a property right, “border flow rights,” and associated financial right, “contracts for differences of differences,” that:
 1. Removes the need for the ISO to be the issuer of transmission rights, allowing for reconfiguration of transmission rights by an entity other than the ISO.
 2. Removes the risk to the ISO of revenue shortfall under transmission outage conditions.
 3. Supports merchant transmission expansion.

3 Hedging of transmission and energy prices

- LMPs and LMP differences provide efficient incentives for generators and consumers and for transmission use.
- Volatility of LMPs prompts the use of financial instruments to hedge against the variation in LMPs.
- Contracts For Differences (CFDs) can be used to hedge LMP volatility for co-located generation and demand.
 - CFDs are written on the underlying revenue stream accruing to a generator and paid by demand.
 - Underlying revenue stream is independent of CFD.
- ISO-issued FTRs can hedge the volatility of LMP differences when there are transmission constraints.
 - FTRs do not have an underlying revenue stream that is independent of the FTR nomination.

3.1 Current implementation of energy and transmission markets

Asset:	Underlying revenue stream:	Financial instrument:
Generation	Energy \times LMP	CFD
Transmission	???	FTR

3.2 Revenue adequacy for the ISO

- FTRs are allocated or acquired in auctions conducted by the ISO.
- FTRs are funded from the congestion rental accruing to the ISO.
- To ensure “revenue adequacy,” the allocated and auctioned rights must satisfy the Simultaneous Feasibility Test (SFT).
- During transmission outage conditions, the congestion rental may be inadequate to fund the FTR obligations, necessitating an ISO-administered derating policy.
- We will change the assumption of ISO funding out of congestion rental and thereby make the ISO revenue neutral under all conditions.

4 Proposed property right

- Should produce a revenue stream that incents the efficient level of transmission investment.
- A central insight of Gribik, Shirmohammadi *et al.* is that Kirchhoff’s voltage law dictates that the contributions of lines to welfare depend not only on their capacity but also on their admittance.
- The proposed property right will reflect this insight and provide an incentive for approximately efficient marginal transmission expansion by coalitions of beneficiaries.

4.1 No contingency constraints

- Ignoring contingencies, for a line between buses k and ℓ , the “border flow right” (BFR) is defined to pay:

$$p_k P_{\ell k} + p_\ell P_{k\ell}, \quad (1)$$

- where the LMPs at buses k and ℓ are p_k and p_ℓ , respectively,
- the power flow from the line into bus k is $P_{\ell k}$, and
- the power flow from the line into bus ℓ is $P_{k\ell}$.
- Line owner is paid at the LMP for energy delivered to the system and pays at the LMP for energy received from the system.
- BFR is equivalent to paying based on the sensitivity of welfare to capacity and admittance multiplied by the capacity and admittance, respectively, as proved by Gribik, Shirmohammadi, *et al.*

4.2 Discussion

- The revenue stream defined in (1) is usually positive but we will consider the case where it can be negative in an example.
- (1) is analogous to the revenue stream paid to a generator for generation and paid by a consumer for its consumption.
- Provides underlying revenue stream that is independent of a financial contract.
- It guarantees revenue neutrality for the ISO.

4.3 Contingency constraints

- Payment involves the sum over base and contingency states of the product of net injection or withdrawal in a state times appropriate Lagrange multipliers.
- For a lossless system and only a single binding contingency constraint, the payment can be evaluated with (1) using the flows on the lines calculated for the contingency case and the LMPs.
- This payment scheme is also revenue neutral for the ISO.

4.4 Approximation

- An approximation in the case of contingency constraints is to use (1) with pre-contingency flows, even when contingency constraints are binding.
- Provides an approximation to efficient marginal incentives for transmission expansion by coalitions of beneficiaries, under the strong assumptions of no lumpiness, no economies of scale, and no market power.

Asset:	Underlying revenue stream:	Financial instrument:
Generation	Energy \times LMP	CFD
Transmission	Energy \times LMP	FTR

5 Example illustrating revenue stream

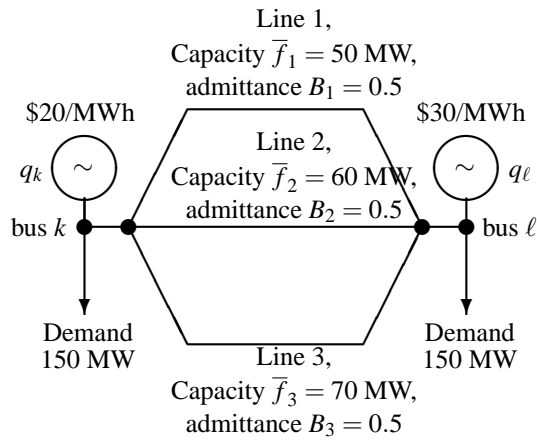

5.1 Offer-based security-constrained economic dispatch

- Security-constrained capability from bus k to bus ℓ is 100 MW.
- Optimal dispatch involves $q_k^* = 250$ and $q_\ell^* = 50$, with $33\frac{1}{3}$ MW flowing on each line from k to ℓ pre-contingency and 50 MW flowing on each remaining line from k to ℓ in the event of any contingency.
- The LMPs at k and ℓ are $p_k = 20$ \$/MWh and $p_\ell = 30$ \$/MWh, respectively.

5.2 Payment based on pre-contingency flows

- Using the approximate payment based on (1) and using the pre-contingency flows, the payments are $333\frac{1}{3}$ \$/h for each line.
- This revenue stream differs from payment based on contingency flows but would be easier to administer and may be a workable approximation to the exact sensitivity calculation.

5.3 Incentives

- Consider a small change to the line.
- Payment based on (1) encourages:
 - line 1 to increase its capacity in order to increase capability from k to ℓ , and
 - lines 2 and 3 to add series capacitors to increase capability from k to ℓ .

6 Example illustrating counterflow from Oren, *et al.*

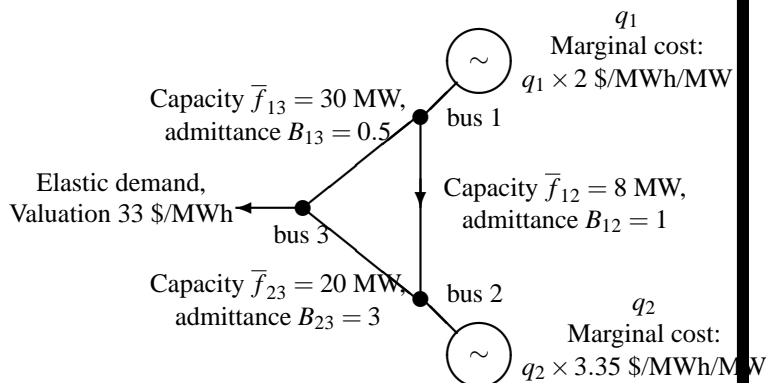

- No contingency constraints.

6.1 Solution with all lines in-service

- Solution is $q_1^* = 15$ MW, $q_2^* = 10$ MW, and LMPs of $p_1 = 30$ \$/MWh, $p_2 = 33.5$ \$/MWh, and $p_3 = 33$ \$/MWh.
- The flow on the line from bus 1 to bus 2 is at capacity $\bar{f}_{12} = 8$ MW and is paid 28 \$/h.
- The flow on the line from bus 1 to bus 3 is 7 MW and is paid 21 \$/h.
- The flow on the line from bus 2 to bus 3 is 18 MW, but the LMP at bus 2 is higher than the LMP at bus 3.
- The line from bus 2 to bus 3 is “paid” -9 \$/h.
- That is, the owner of the line from bus 2 to bus 3 must pay the ISO under (1).

6.2 Incentives

- The payment to the owner of the line joining bus 2 to bus 3 receives a negative payment under (1).
- This is because the marginal contribution of the line to the welfare is *negative*.

6.3 Summary

- This example illustrated the case of counterflow where power flows on a line from a higher to a lower priced bus.
- Under BFRs, such a line would receive a negative payment, encouraging it at the margin to reduce the flow and improve the dispatch.
- Although this may seem counter-intuitive, this incentive is correct in sign for marginal changes.
 - Incentives may have wrong sign for large changes.

7 Proposed financial right

- We describe a financial transmission right funded from the revenue stream of BFRs.
- Consider a generator located at a bus k that has written a CFD with a consumer that hedges energy prices as bus k .
- If the consumer is located at another bus ℓ then the consumer is exposed to the LMP difference between bus ℓ and bus k .
- That is, the consumer is exposed to transmission price risk.

7.1 Contracts for differences of differences

- We propose a hedging instrument to hedge the transmission price risk.
- The CFDD is a contract between:
 - the consumer (or generator or both), and
 - the owner of the transmission line or lines joining bus k and ℓ .
- The CFDD provides for a side payment to the transmission line owner equal to a contract quantity times the difference between:
 - a strike price for transmission services, and
 - the *difference* between the LMPs at bus k and ℓ .
- The CFDD is so-called because it pays based on the *difference* between a strike price and LMP *differences* between two buses.
 - Similar to “basis spread” but is not speculative if funded out of BFR.
 - CFDD is analogous to a CFD but hedges transmission price.

7.2 Discussion

- A transmission owner and its transmission customer have equal and opposite exposures to the variation of LMP differences.
- As with the CFD, the CFDD allows them both to hedge their price risk for the quantity q .

Asset:	Underlying revenue stream:	Financial instrument:
Generation	Energy \times LMP	CFD
Transmission	Energy \times LMP	CFDD

7.3 Revenue adequacy

- In the case of an FTR-only system, revenue adequacy for the ISO requires the FTRs to satisfy the SFT test.
- With BFRs and CFDDs, revenue adequacy is devolved to transmission line owners.
- The transmission owner is financially responsible for its outages and must consider the implications in setting the strike price, contract quantity, and any derating terms in its contract with transmission customers.
- Risks to transmission customers under outage conditions would be explicitly set out in the contract rather than being implicit in a collection of ISO rules for derating FTRs.

8 Trading of CFDDs

- CFDDs allow for trading of financial transmission rights by entities other than the ISO because the simultaneous feasibility test to protect the revenue adequacy of the ISO is not part of the CFDD mechanism.
- CFDD trading could be decentralized.
- CFDD trading could be arranged by an exchange that also traded CFDs, so that transmission and energy could be traded together.
 - Avoids bifurcation in current markets between long-term energy trading and long-term transmission rights trading.

9 Merchant construction

9.1 Discussion

- Merchant transmission providers can utilize forward markets to enable them to sign long-term contracts to finance construction and also lock in LMP differences.
- Because of lumpiness and economies of scale in transmission construction, a transmission addition may significantly reduce LMP differences between the ends of the line at least during the first years of operation of a line until demand grows.
- Signing contracts based on forward nodal energy price differences allows merchant transmission investment to be profitable despite temporarily depressing the LMP difference.

9.2 Incentives

- In an FTR system, any expansion that is detrimental to the grid will result in FTRs that have negative value to the builder.
- Such a result does not extend to our proposed revenue stream as defined in (1).
 - Transmission might be profitable under (1) despite lowering welfare overall.
- A natural solution to this issue is to provide the ISO with flexibility to “commit” or “de-commit” transmission lines in a way that is analogous to commitment of generation.
 - A line that lowers welfare would be de-committed.

9.3 Transmission expansion by coalitions

- Under BFRs, the benefit due to an expansion of the capacity of a line may also accrue to other lines.
- Consequently, even in the absence of lumpiness, an efficient level of investment requires financing by coalitions of beneficiaries.
- Although coalition funding is somewhat cumbersome and presents free-rider problems, transmission expansion currently involves such mechanisms in many jurisdictions.
- The border flow rights mechanism formalizes a property right for such expansion.

9.4 Example

- Consider again the two bus, three line network from Section 5.
- Consider an expansion of the capacity of line 1 by 1.5 MW, with no change in admittance.
- This expansion increases the capability to import power from bus k to bus ℓ by 3 MW, increasing welfare by $(3 \text{ MW}) \times (\$30/\text{MWh} - \$20/\text{MWh})$, or \$30/h, due to the decrease in generation at bus ℓ and the increase in generation at bus k .
- The flows on each line increase by 1 MW and each line receives an additional payment of \$10/h.
- That is, the total increase in welfare of \$30/h due to the transmission expansion is paid out to the lines.
- A coalition of the owners of the three lines could finance the expansion of line 1 if the cost of expansion were compensated by the total increase in welfare of \$30/h.

10 Conclusion

10.1 Property right

- Proposed a property right for transmission based on the approach of Gribik, Shirmohammadi, *et al.* by defining an underlying revenue stream that accrues to the owner of a transmission line.
- The owner of a transmission line is paid or pays at the locational marginal price for energy that it delivers to or receives from the rest of the system.
- Border flow rights using pre-contingency flows provide an approximation to efficient marginal incentives for transmission expansion by coalitions of beneficiaries.

10.2 Financial right

- Based on the property right for transmission, we have proposed a financial right for hedging LMP differences, called a contract for differences of differences (CFDD).
- The CFDD is based on the underlying revenue stream in the BFR.
- Unlike previous FTR formulations, we *first* define a property right in terms of an underlying revenue stream that is independent of FTR nominations and *then* define a financial right that is built on the underlying property right.

10.3 Trading

- CFDDs can be traded without an ISO.
- Nevertheless, exchange trading of CFDDs has several advantages over completely decentralized trading.
- Both transmission and energy can be traded forward in one exchange, avoiding the bifurcation in current long-term markets.

10.4 Merchant expansion and transmission regulation

- Have not solved all the problems associated with merchant expansion!
- Have clarified that the “difficulty” with regulating (and deregulating) transmission is not due to the specifics of Kirchhoff’s laws but is rather due to lumpiness, economies of scale, and market power.

Acknowledgment

This work was funded in part by the Federal Energy Regulatory Commission. The ideas build, in part, on discussions with Professor Rubén Darío Cruz of Universidad Industrial de Santander, Colombia, during his visit to The University of Texas at Austin in 2002. Discussions with Richard O’Neill and Emily Bartholomew of the Federal Energy Regulatory Commission, Benjamin Hobbs, Steven Stoft, and Karsten Neuhoff are gratefully acknowledged. I would also like to thank the five anonymous reviewers for their comments.