



Automatic Slow Voltage Controller for Large Power Systems

Mani V. Venkatasubramanian

**Washington State University
Pullman WA**

Objectives



- **Automatic switching of shunt capacitors, reactors, transformer taps, and generator high side voltages**
- **Maintain voltage profile**
- **Minimize switching actions**
- **Mitigate circular VAR flows**
- **Reduce P and Q losses**
- **Monitor voltage security**
- **Alert ahead of unusual operating conditions**

Motivation



- **Developed for western Oregon subsystem of Pacific Northwest operated by BPA**
- **Project funded by BPA and by CERTS through PSerc**
- **Doctoral thesis of Yonghong Chen, August 2001**
- **Prototype implementation on-going since October 2001**
- **National Systems and Research Co. (NSR) in charge of implementation.**
- **<http://www1.nsrvan.com/avc>**

Literature review



- **Secondary voltage control in Europe: Divide into control areas and pilot point voltages**
- **OPF based control in Belgium: primarily for coordination of generator and shunt devices**
- **OPF based EMS scheme in PEPCO: optimal solution implemented by predefined control priorities**
- **Prior approaches designed for continuous controls. Discrete devices approximated.**

Western Oregon region



- **Away from generators**
- **Voltage control primarily by discrete devices**
- **Capacitor/reactor banks, LTC transformers**
- **Multiple banks at one bus**
- **Close proximity of devices – strongly coupled.**
- **Inherently a discrete control problem**

Overview of Control Devices



Capacitor/Reactor Banks:

ALBANY 115 (50), ALVEY 115 (20, 20, 26)

ALVEY 230 (59,59,59,118), CHEMAWA 115 (24)

CHEMAWA 230 (54), LANE 115 (30), LANE 230 (59,108)

SANTIAM 230 (147), STMARYSA115 (22)

STMARYSB115 (22), TILAMOOK 115 (23, 30)

TOLEDO 69 (15, 15, 27), TOLEDO 230 (30)

DIXONVILLE 500 (-149, -149), MARION 500 (-248)

LTC Transformers:

ALVEY 230 – ALVEY 115 1, ALVEY 230 – ALVEY 230 2

ALVEY 500 – ALVEY 230 5, DIXONVILLE 230 – DIXONVILLE 115 1

DIXONVILLE 230 – DIXONVILLE 115 2

Generator High Side Voltages:

JOHN DAY 500 (1.03 – 1.10), BIG EDDY 230 (1.03 – 1.10)

Present operation



- **Visits to BPA Munro control center**
- **Respond to voltage alarms and outages**
- **Keep track of expected load changes and switch early**
- **Minimize number of switchings**
- **Keep maximum devices in reserve**
- **Avoid tap changes whenever possible**
- **Avoid circulating VAR flows**
- **Watch for bad data and false alarms**

Proposed Control Framework

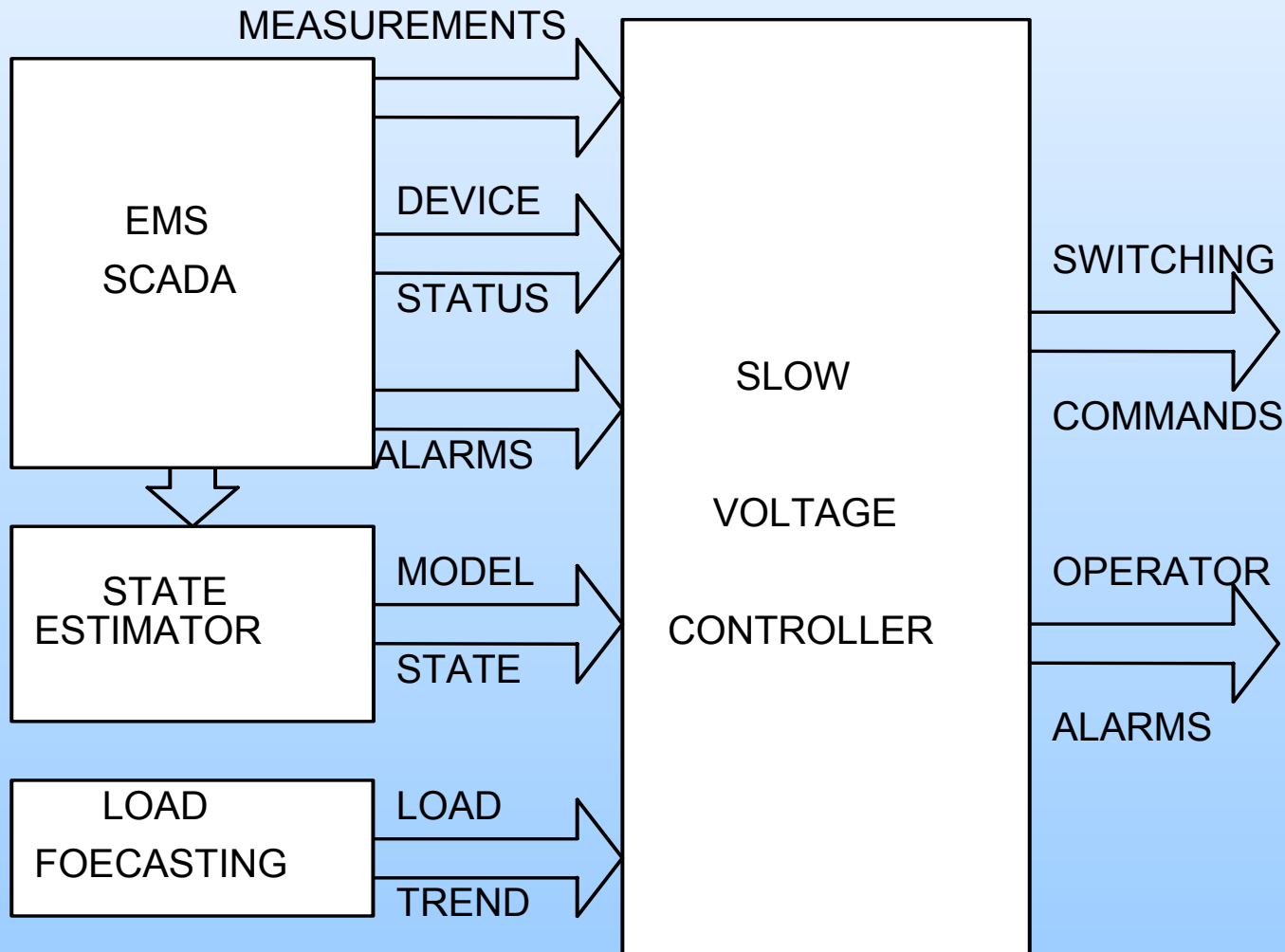

Controller objectives



Present Formulation:

- Maintain voltage profile
- Minimize number of switchings
- Maintain control preferences
- Minimize circulating VAR flow

Future Formulation:

- Minimize losses
- Monitor voltage security

Proposed Controller



- **Nonlinear integer programming**
- **Using adaptive local power-flow computations to evaluate control effects**
- **Multiple power-flow cases from load forecasting considered in control decision**
- **Circular VAR flow detection and minimization**
- **Fast computation scalable to large systems**
- **One switching at a time suggested**
- **An approximate method for solving multiple switchings**

Problem Formulation

$$\text{Min} \quad \sum_{i=1}^n |k_i| C_i + \sum_{m=1}^M p_m [F_m(k_1, \od�, k_n) + \lambda g_{cir,m}(k_1, \od�, k_n)]$$

$$s.t. \quad \sum_{i=1}^n |k_i| \leq N_{sw}$$

$$k_i \in \{-1, 0, 1\}$$

Switching Cost of
Device i

Voltage Violation
Penalty

Circular VAR Flow
Penalty

Maximum Number of
Switchings per
Iteration

Cost Formulation



1) Switching cost of control device C_i :

- Higher cost for switching in a device than switching out
- Higher cost for tap changers compared to capacitor and reactor banks
- Cost increases distinctly after one switching and decreases slowly afterwards

Cost Formulation



- 1) Switching cost
- 2) Voltage Penalty Function:

$$\sum_{i=1}^{nbus} |f_i|$$

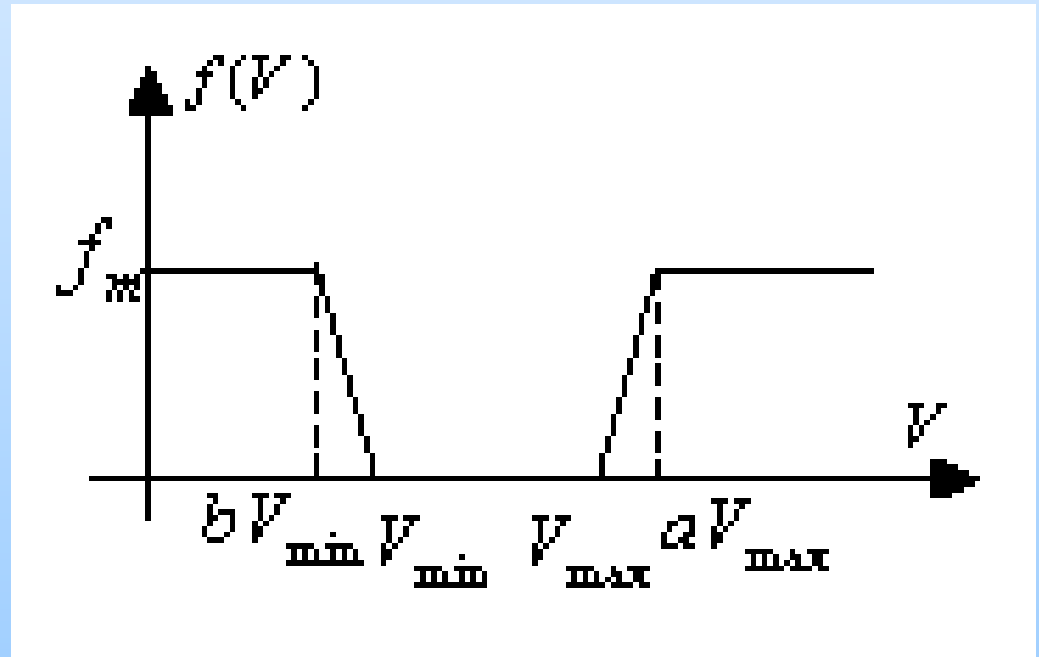

Localized Computations



- **Switching effect computed locally from adaptive localization.**
- **First keep only the buses within 10 tiers from the candidate control device.**
- **Calculate electric distance (ED) and leave out the buses with ED sufficiently large from the control device bus location.**
- **Leave out all the PV buses.**
- **Repeat for other candidate devices.**

Local Power-flow Example



Insertion of ALVEY 230 122MVAR Cap bank:

- Local system with 163 buses
 - *Tier =1 nbus=1*
 - ALVEY 230
 - *Tier=2 nbus=7*
 - ALVEY 115
 - DIXONVLE 230
 - E SPRING 230
 - LANE 230
 - MARTINTP 230
 - SPENCER 230
 - ALVEY 500
- | | <i>V0</i> | <i>V_loc</i> | <i>V_BPA</i> |
|--------------|-----------|--------------|--------------|
| ALVEY 230 | 1.0144 | 1.0297 | 1.030 |
| ALVEY 115 | 1.0232 | 1.0360 | 1.035 |
| DIXONVLE 230 | 0.9887 | 0.9979 | 0.999 |
| E SPRING 230 | 1.0144 | 1.0282 | 1.029 |
| LANE 230 | 1.0178 | 1.0283 | 1.029 |
| MARTINTP 230 | 1.0020 | 1.0164 | 1.017 |
| SPENCER 230 | 1.0138 | 1.0288 | 1.029 |
| ALVEY 500 | 1.0394 | 1.0509 | 1.052 |

Basic Optimization Procedure



Assume $N_{sw} = 1$ One switching at a time.

$m = 1$: One power-flow case:

- Find worst violation bus w .
- Choose all control devices that have w in their local systems.
- Solve local power-flows and evaluate switching effects and the device cost function
- Switch the device with minimum cost

Robust Optimization



- **$m > 1$: Multiple power-flow cases:**
 - m possible power flows, each with probability p_i ($i=1, \dots, m$).
 - Find the control action that minimizes the weighted average of voltage penalty from multiple power-flows.

Robust Optimization Example



- **3 possible cases from load forecasting:**

- Power flow 1: current power flow ($p_1=20\%$)
- Power flow 2: +300 MW load ($p_2=20\%$)
- Power flow 3: +580 MW load for a long time ($p_3=60\%$)

- Maximum voltage violation and cost from robust control

| | Case 1 | Case 2 | Case 3 | obj. function |
|---------------------------------|--------------|--------------|---------------|---------------|
| • No switching | 2.47% | 1.46% | -1.89% | 942 |
| • Cap1 (58 MVAR at ALBANY115) | 2.47% | 1.46% | -1.89% | 943 |
| • Cap2 (25MVAR at CHEMAW115) | 2.47% | 1.46% | -1.89% | 943 |
| • Cap3 (54 MVAR at CHEMAW230) | 2.47% | 1.46% | -2.11% | 1601 |
| • Cap4 (78 MVAR at LANE 230) | 1.85% | -1.07% | -2.37% | 2220 |
| • Cap5 (30 MVAR at TILLMOK 115) | 2.47% | 1.46% | -2.17% | 4056 |

Cost Formulation

- 1) Switching cost
- 2) Voltage violation penalty
- 3) Circular VAR flow penalty:
 - Identify all loops with circulating VARs
 - Minimum branch VAR is defined as the circulating VAR through the loop
 - Sum of the circulating VAR over all loops

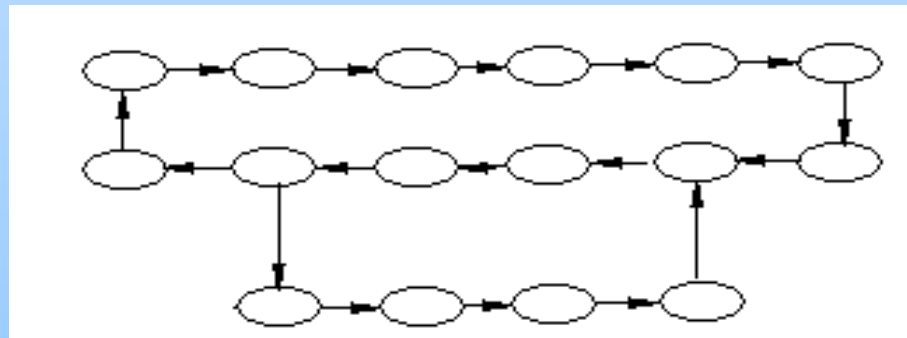

A Necessary Condition

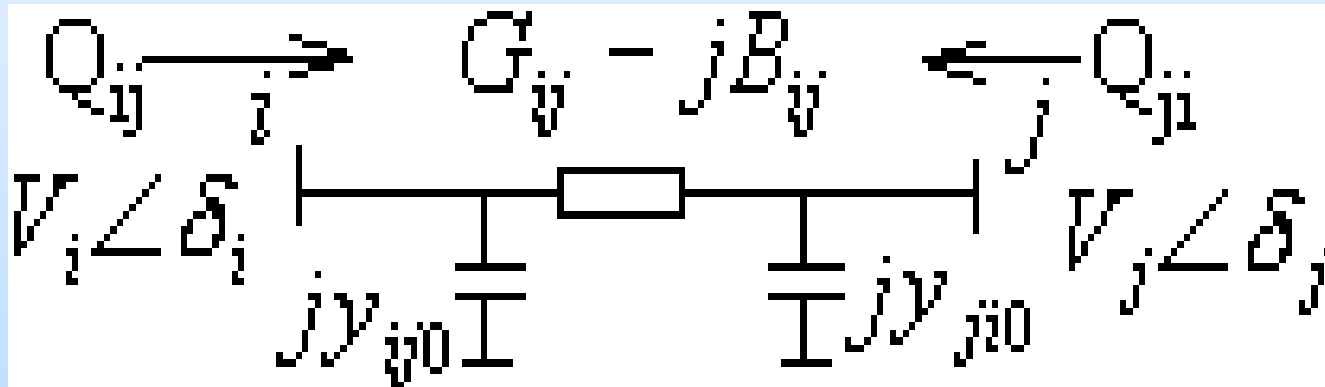

Suppose $Q_{ij} > 0$ and $Q_{ji} < 0$, and $\cos(\delta_i - \delta_j) > 0$

Line is symmetric $\Rightarrow V_i > V_j$

Circular VAR Flow Computation



- **Necessary condition : At least one asymmetric line branch must be present in each circular VAR flow loop.**
- **Start with LTC transformer banks, lines with series compensation.**
- **Directed graph theory – depth first search.**
- **Loops can be identified efficiently.**

Cost Formulation

$$\text{Min} \quad \sum_{i=1}^n |k_i| C_i + \sum_{m=1}^M p_m [F_m(k_1, \od�, k_n) + \lambda g_{cir,m}(k_1, \od�, k_n)]$$

$$\text{s.t.} \quad \sum_{i=1}^n |k_i| \leq N_{sw}$$

$$k_i \in \{-1, 0, 1\}$$

$N_{sw} = 1$ One switching at a time:

Find the device with minimum cost among the candidate devices.

Multiple switching $N_{sw} > 1$



Approximate methods proposed.

- Greedy algorithm
 - Always makes the choice that looks best at the moment.
 - Quick suboptimal solutions for feasibility
- Dynamic programming / branch bounding method from linear approximation

$$\text{Min} \quad \sum_{i=1}^n |k_i| C_i$$

$$\text{s.t.} \quad V_{\min} \leq V_0 + \sum_{i=1}^n k_i \cdot dV_i \leq V_{\max}$$

$$\sum_{i=1}^n |k_i| \leq N_{sw}$$

Controller configuration

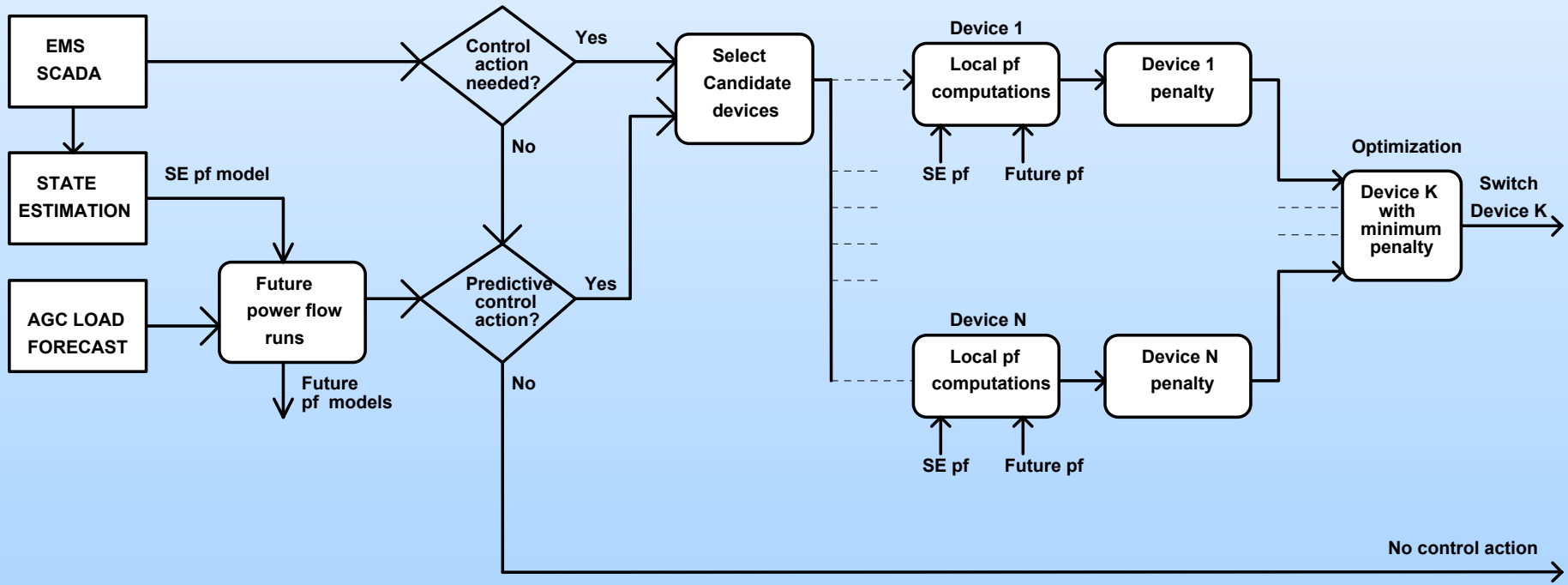

Prototype Implementation



- **National Systems and Research Co.**
 - Ramu Ramanathan, V. Venkataramakrishnan, Qinsheng Huang, ...
- **Bonneville Power Administration**
 - Carson Taylor, Project Manager
 - Planning and operations engineers, operators
- **Washington State University**
 - Mani, Jing Dong Su

Software Architecture

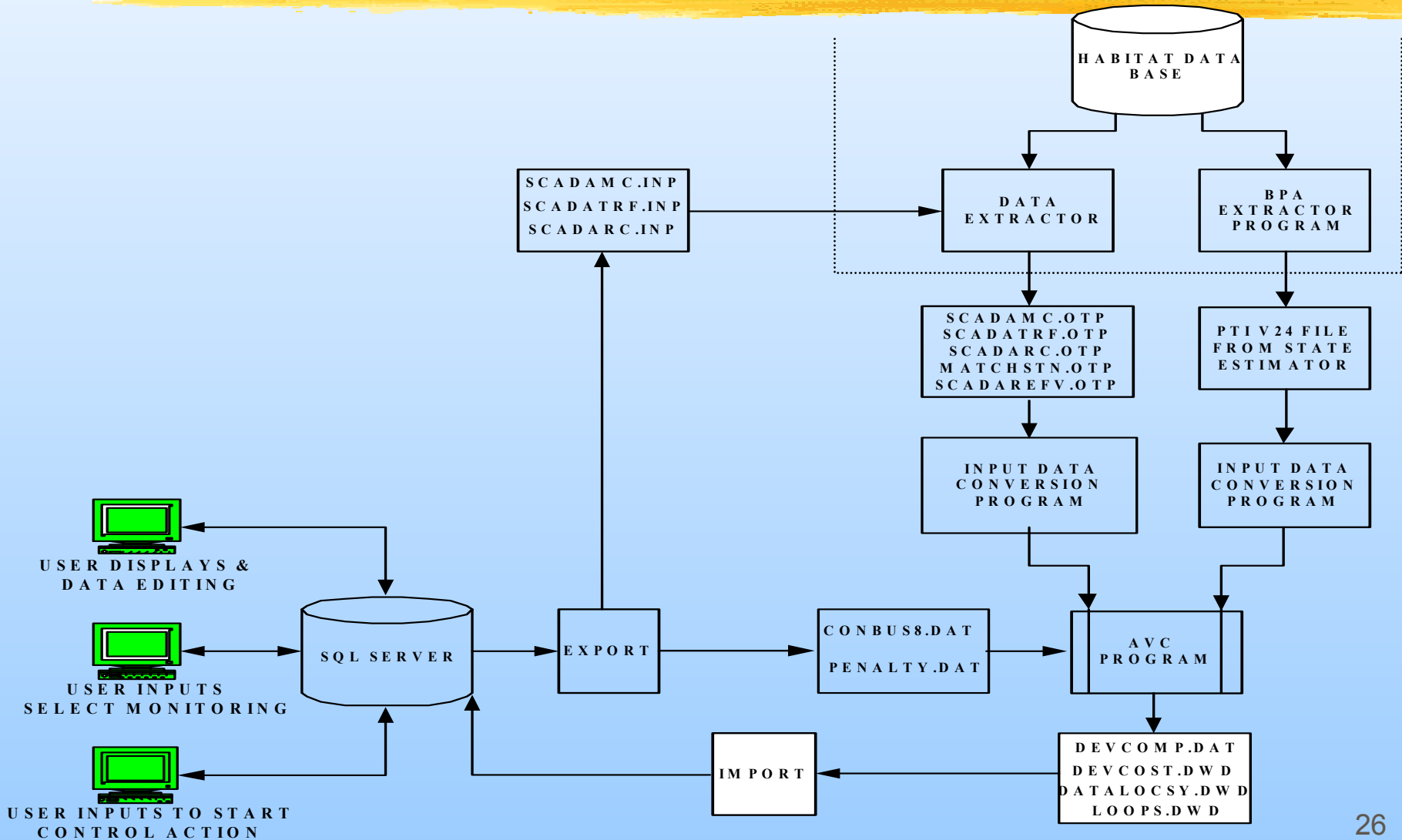

Implementation Status at NSR

- **Web-based interface at <http://www1.nsrvan.com/AVC>**
- **Developed the displays, interfaces with SCADA and state estimator**
- **Adopted AVC program to the entire BPA grid**
- **Testing and tuning of the controller in progress with input from BPA**

Current research at WSU



- **Back-up heuristic controllers that run only from SCADA measurements.**
- **Device status, power-flows and voltages assumed known.**
- **Switching effects approximated.**
- **Doctoral thesis of Jing Dong Su**
- **Detection of bad data and false alarms**
- **Large system considerations**
- **Other capabilities.**