

# Day-4

## Custom Power Compensating Devices

Arindam Ghosh

Dept. of Electrical Engineering

Indian Institute of Technology

Kanpur, India

E-mail: [aghosh@iitk.ac.in](mailto:aghosh@iitk.ac.in)

# Load Compensation using DSTATCOM

The primary goals of a DSTATCOM are

- to cancel the effect of poor load power factor such that the current drawn from the source has a near unity power factor.
- to cancel the effect of harmonic contents in loads such that current drawn from the source is nearly sinusoidal.
- to offset the effect of unbalanced loads such that the current drawn from the source is balanced.

In addition, it can also eliminate dc offset in loads.

## Ideal DSTATCOM

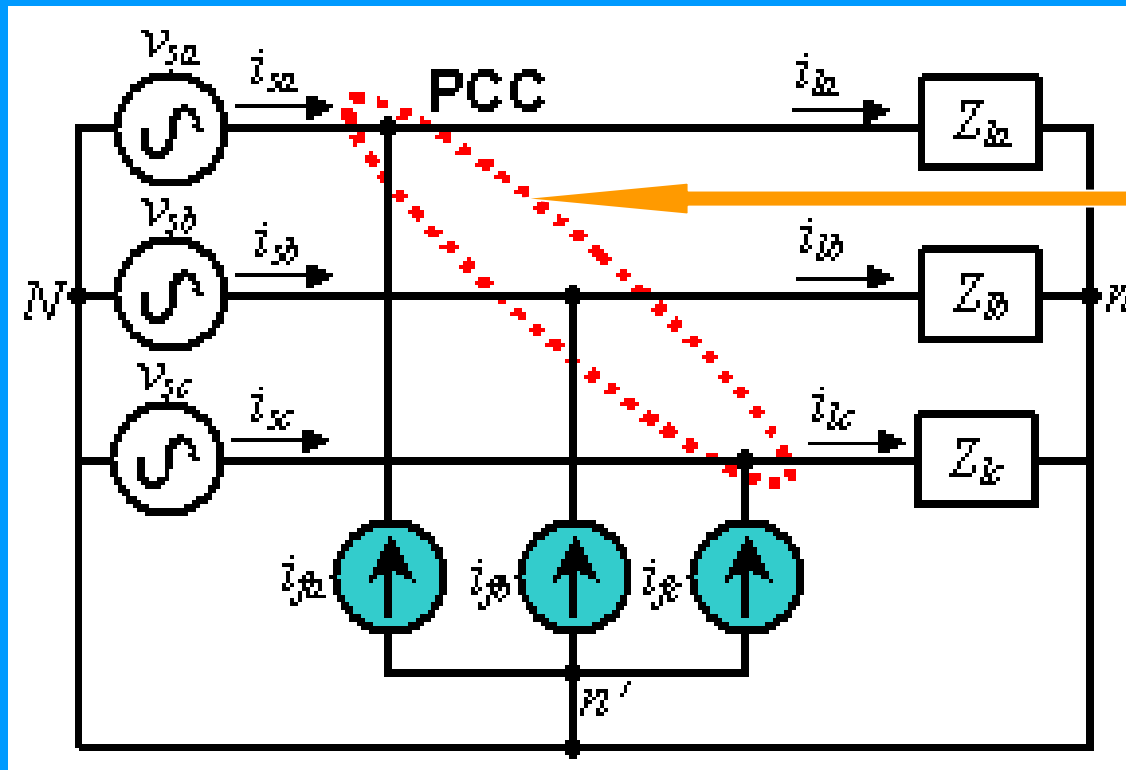

Point of  
common  
coupling

- Source voltage:  $v_s$  source current:  $i_s$  load:  $Z_l$  load current:  $i_l$
- The DSTATCOM: current sources  $i_{fa}$ ,  $i_{fb}$  &  $i_{fc}$

- Inject a set of currents such that the source currents are balanced and sinusoidal.
- If the load is unbalanced then the zero-sequence current circulates in the path joining the neutral of the load ( $n$ ) and the compensator ( $n'$ ) such that the current flowing through the neutral ( $N$ ) is zero.
- Additionally power factor correction can also be performed such that the DSTATCOM supplies part or whole of the reactive power required by the load.

## DSTATCOM – Reference Generation

- Generate a set of reference currents  $i_{fa}^*$ ,  $i_{fb}^*$  and  $i_{fc}^*$ .
- These currents when injected into the system will simultaneously perform the following three tasks.
  - a) Force the zero-sequence source current to be zero, i.e.,

$$i_{sa} + i_{sb} + i_{sc} = 0$$

- This guarantees that the zero-sequence current flowing through the source neutral is zero in a 3-phase, 4-wire system

b) Force the angle between the source voltage and current to be a specified value, i.e.,

$$\angle(v_{sa}) = \angle(i_{sa}) + \phi$$

$$\angle(v_{sb}) = \angle(i_{sb}) + \phi$$

$$\angle(v_{sc}) = \angle(i_{sc}) + \phi$$

- In the above,  $\phi$  is pre-specified.
- If  $\phi = 0$ , the source voltage and load current are in phase. This will be called the unity power factor (upf) operation.

## DSTATCOM – Reference Generation

- c) The DSTATCOM must not absorb/generate any real power in the steady state, i.e., it only supplies zero-mean oscillating power.

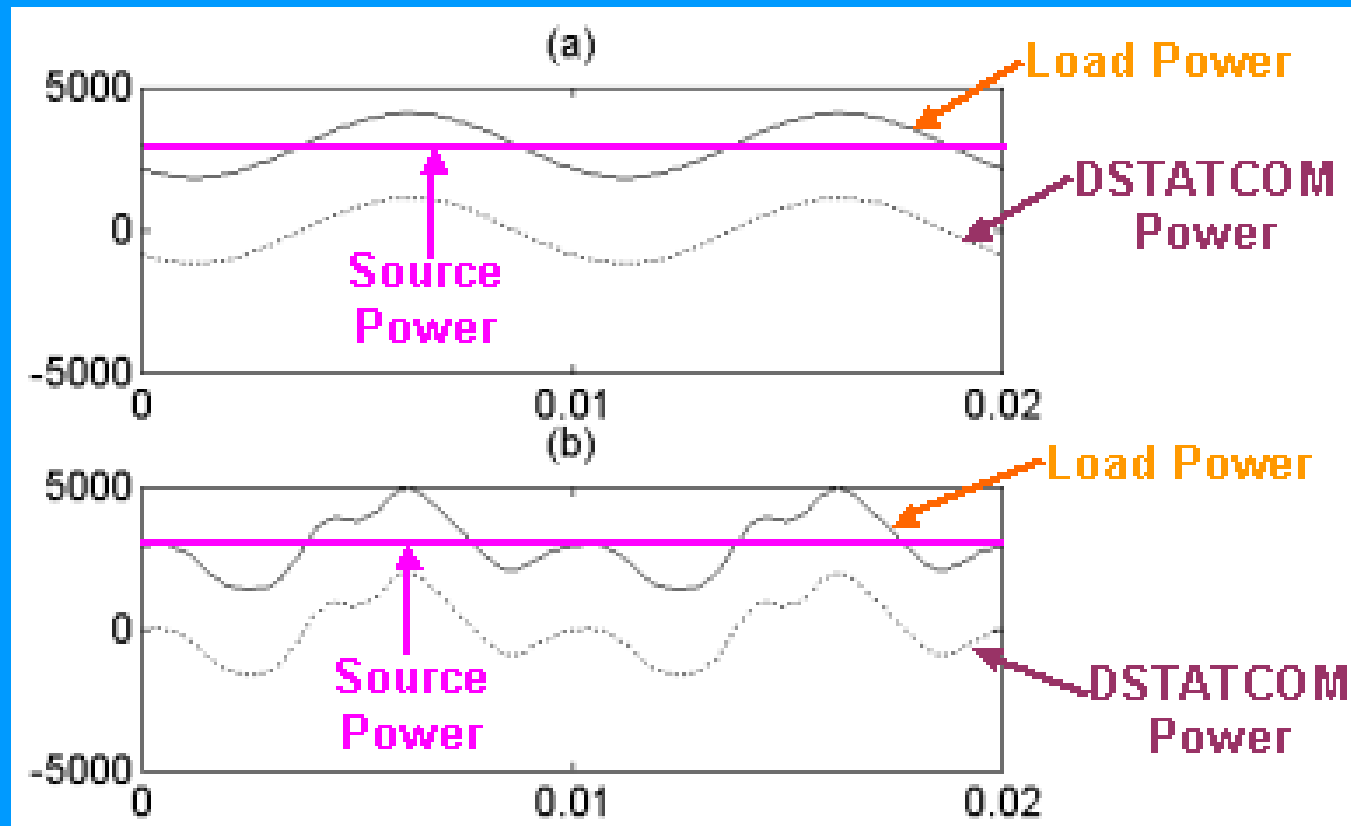

- The power condition can be written as

$$v_{sa} i_{sa} + v_{sb} i_{sb} + v_{sc} i_{sc} = p_{lav}$$

- In the above  $p_{lav}$  is the average power drawn by the load.
- To calculate it on line, 3 Hall-effect voltage and 3 current transformers are required.
- A low-pass Butterworth (or Chebyshev) filter can be used. It will have longer settling time.
- Alternatively a moving average filter settles in just half (or full) cycle.

- Since

$$i_{fk} = i_{lk} - i_{sk}, \quad k = a, b, c$$

- The reference currents are

$$\left. \begin{aligned} i_{fa}^* &= i_{la} - \frac{v_{sa} + (v_{sb} - v_{sc})\beta}{v_{sa}^2 + v_{sb}^2 + v_{sc}^2} P_{lav} \\ i_{fb}^* &= i_{lb} - \frac{v_{sb} + (v_{sc} - v_{sa})\beta}{v_{sa}^2 + v_{sb}^2 + v_{sc}^2} P_{lav} \\ i_{fc}^* &= i_{lc} - \frac{v_{sc} + (v_{sa} - v_{sb})\beta}{v_{sa}^2 + v_{sb}^2 + v_{sc}^2} P_{lav} \end{aligned} \right\}, \quad \beta \equiv \tan \phi / \sqrt{3}$$

## DSTATCOM – Ideal Compensation

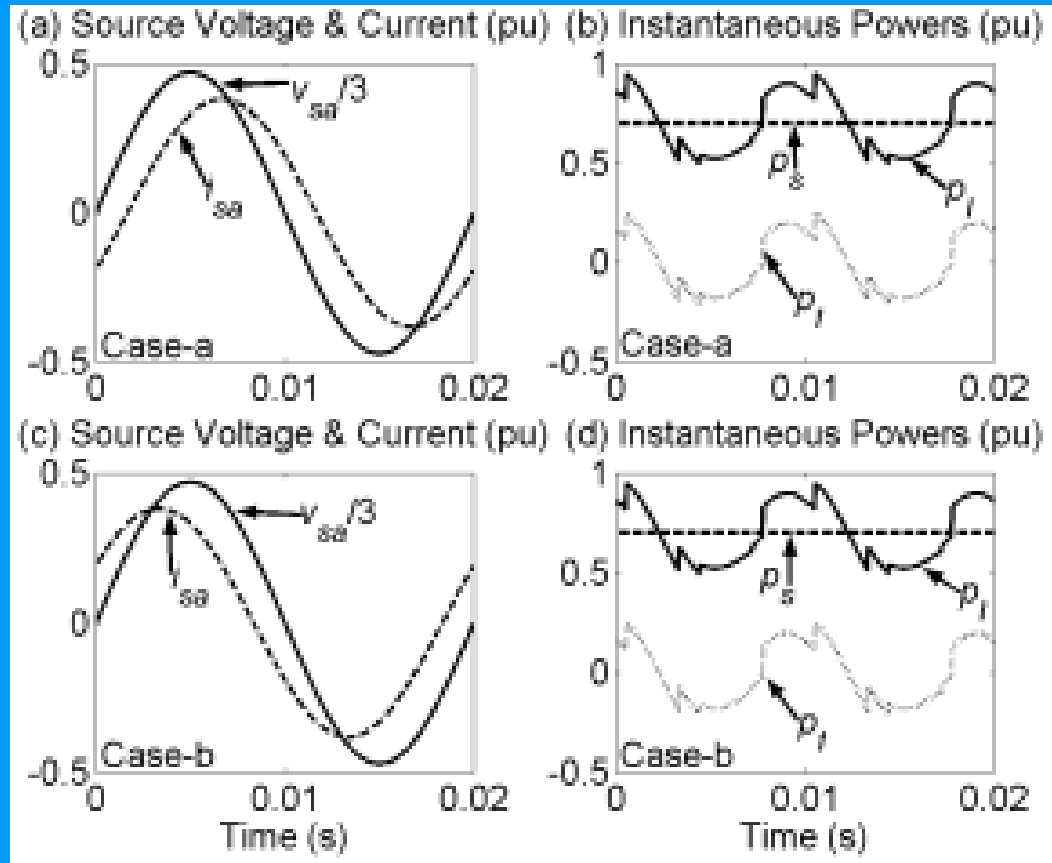

$$\phi = -30^\circ$$

$$\phi = 30^\circ$$

In a similar way the algorithm can be applied to 3p, 3w systems with both star and delta connected loads.

A DSTATCOM is realized by a VSC. The VSC is supplied by a dc capacitor. The DSTATCOM must meet the following requirements:

- It should be able to inject distorted and negative-sequence currents.
- It must be able to provide a circulating path for the zero-sequence load current such that it does not travel towards the source.
- It must be able to regulate the voltage dc capacitor such that no external battery source is required.

## DSTATCOM Structure

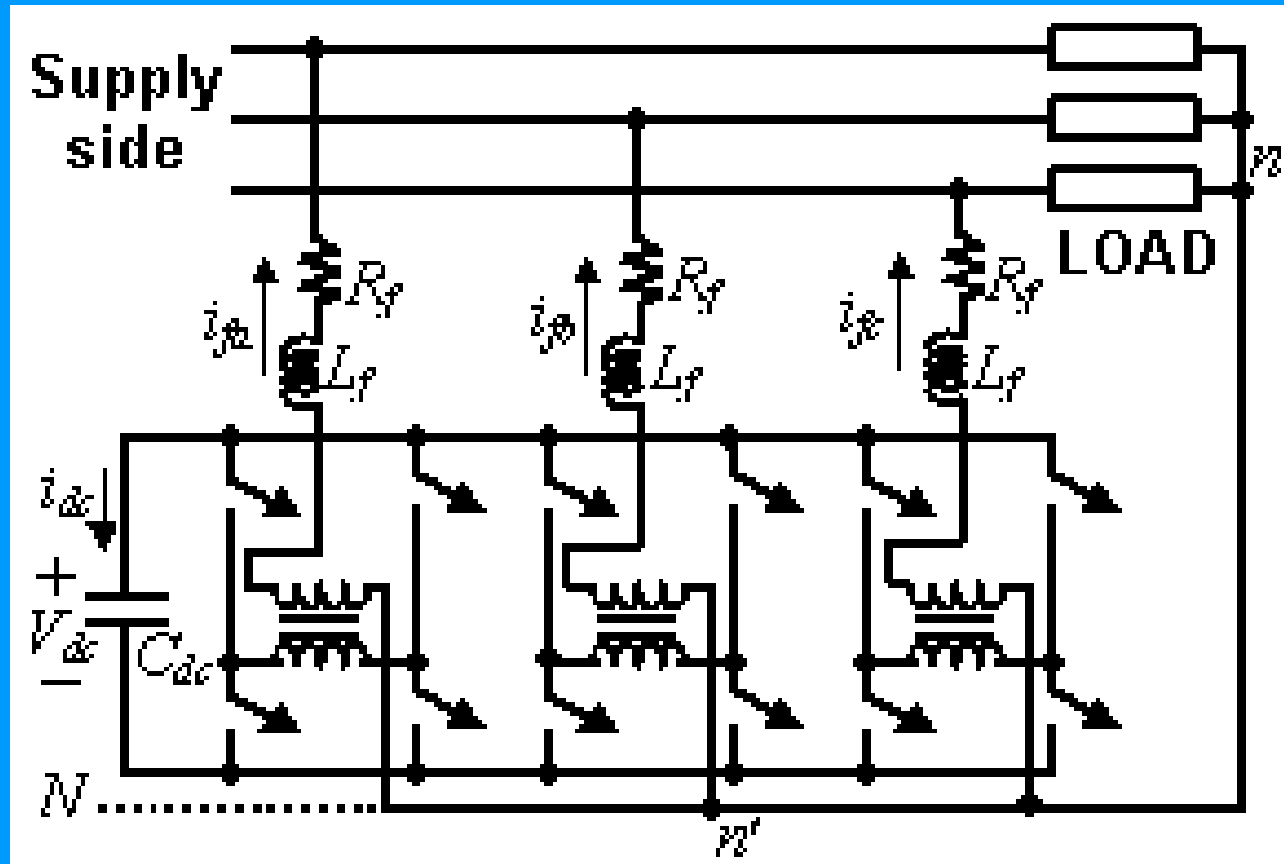

My favorite structure

- A common dc capacitor makes the distribution of power easier.
- The transformers provides isolation in addition to voltage step down.

## DSTATCOM Structure

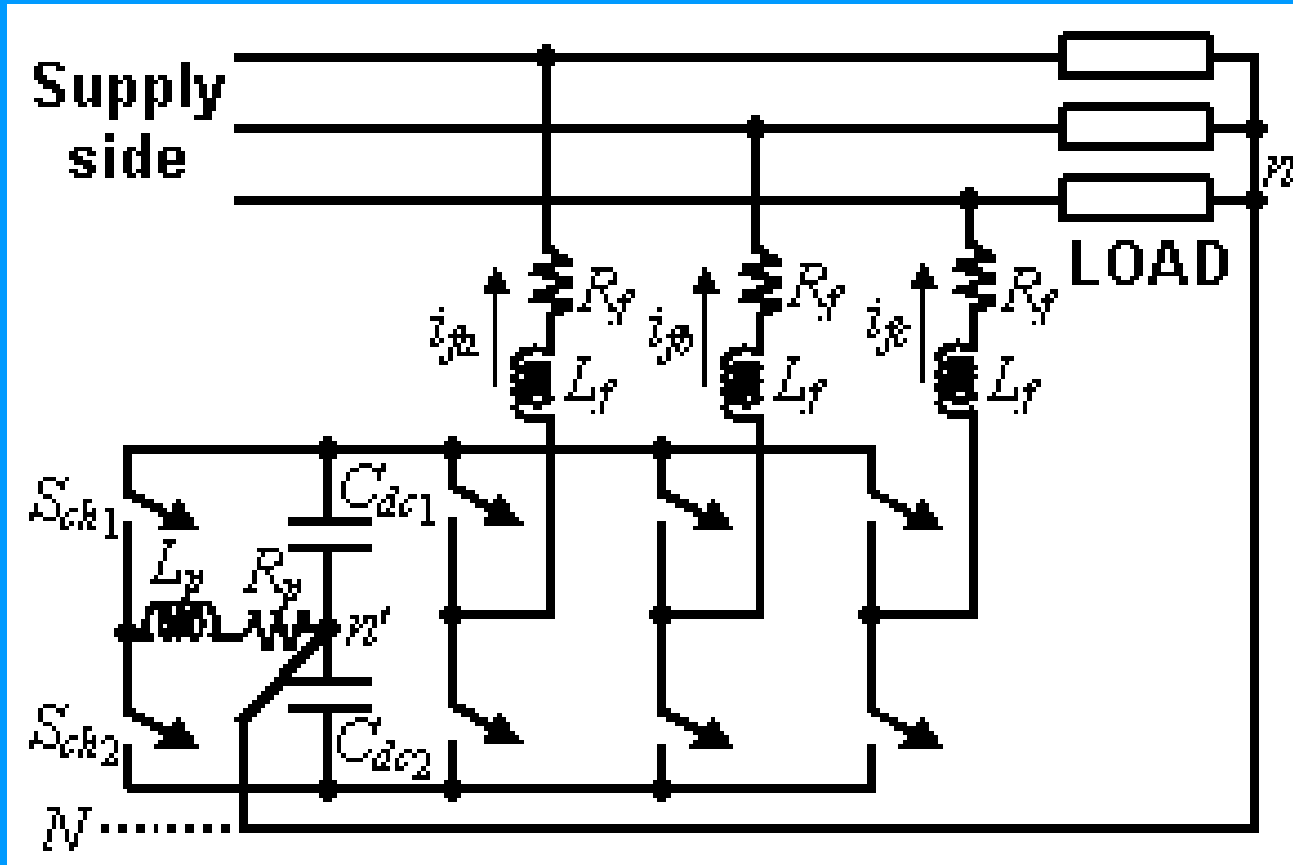

- Suitable for dc compensation.
- Two capacitors ( $C_{dc1}$  and  $C_{dc2}$ ) required.
- An additional chopper circuit containing  $S_{ch1}$ ,  $S_{ch2}$ ,  $R_p$  and  $L_p$  required.

## DSTATCOM Structure

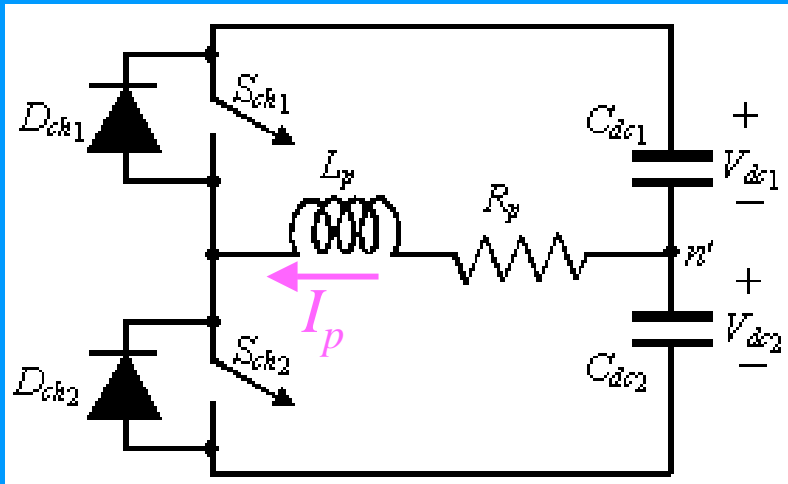

- Normally the switches  $S_{ch1}$  are  $S_{ch2}$  open.
- Suppose  $V_{dc1}$  drops and  $V_{dc2}$  rises.
- $S_{ch2}$  is closed.
- Current  $I_p$  builds up in  $L_p$  in the direction shown.
- Also the voltage  $V_{dc2}$  falls.
- Once  $I_p$  builds up to a desired level,  $S_{ch2}$  is opened.
- The current  $I_p$  discharges through  $D_{ch1}$  charging the capacitor  $C_{dc1}$ .
- The voltage  $V_{dc1}$  rises.

## DSTATCOM Structure

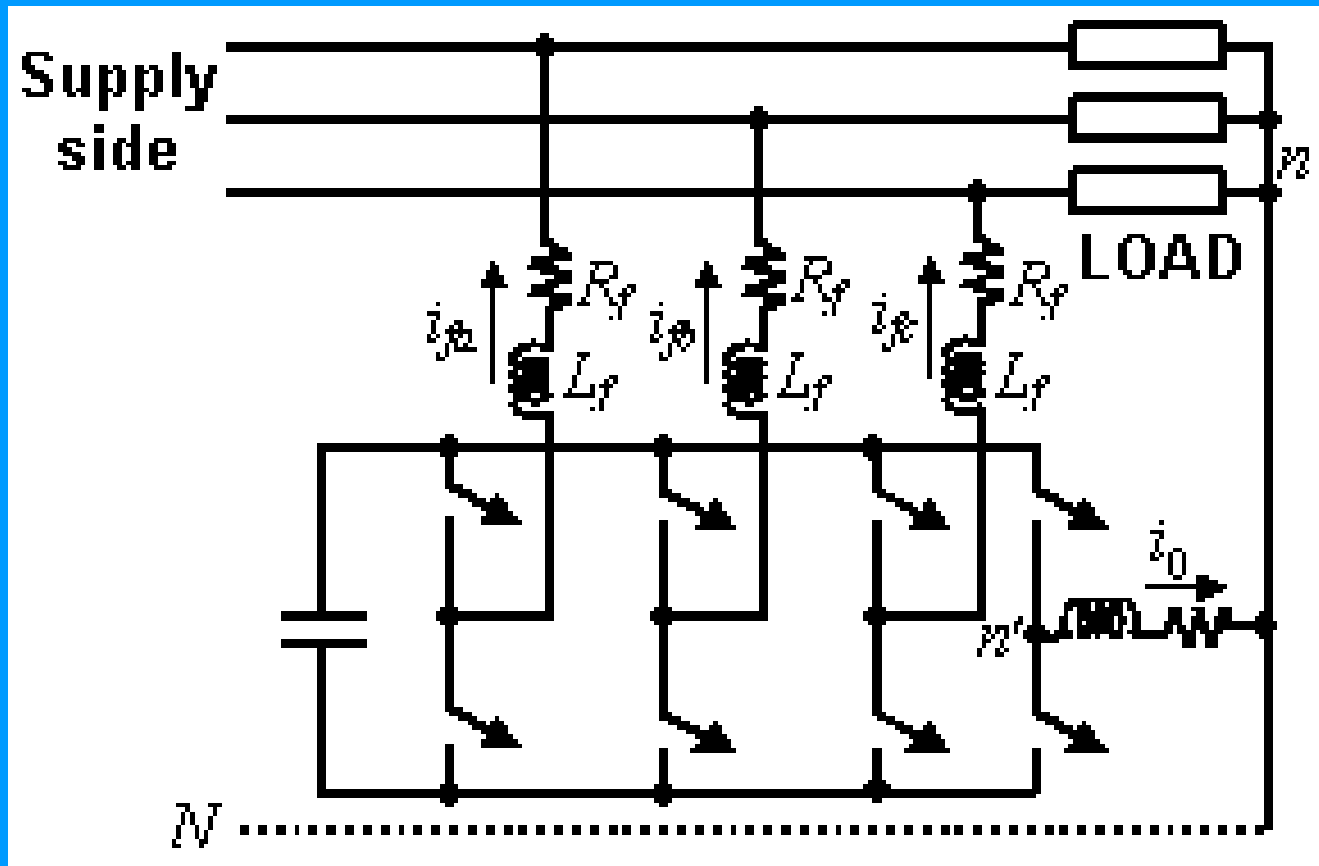

- Zero sequence current is routed to path  $n-n'$ .
- This must be supplied by the 4<sup>th</sup> leg.
- Complexity and switching losses increase.

- The dc voltage supplying the DSTATCOM must be held constant irrespective of the losses in the circuit.
- This can be accomplished by drawing power from the ac system to compensate for the losses.
- The power equation then must be modified to incorporate the losses as

$$v_{sa} i_{sa} + v_{sb} i_{sb} + v_{sc} i_{sc} = p_{lav} + p_{loss}$$

- The reference current equations also get modified in which  $p_{lav}$  is replaced by the sum  $p_{lav} + p_{loss}$ .

- Here  $p_{loss}$  is generated by dc capacitor control loop.
- A PI controller is used for generating this

$$p_{loss} = K_P e + K_I \int e dt$$

$$e = V_{ref} - V_{dc,av}$$

- $V_{ref}$  is the reference dc voltage and  $V_{dc,av}$  is the average dc voltage.
- Any deviation of the capacitor voltage from the reference is due to losses.
- The PI controller loop draws the loss from the ac system to hold the voltage constant.

# DSTATCOM – Hysteresis Control

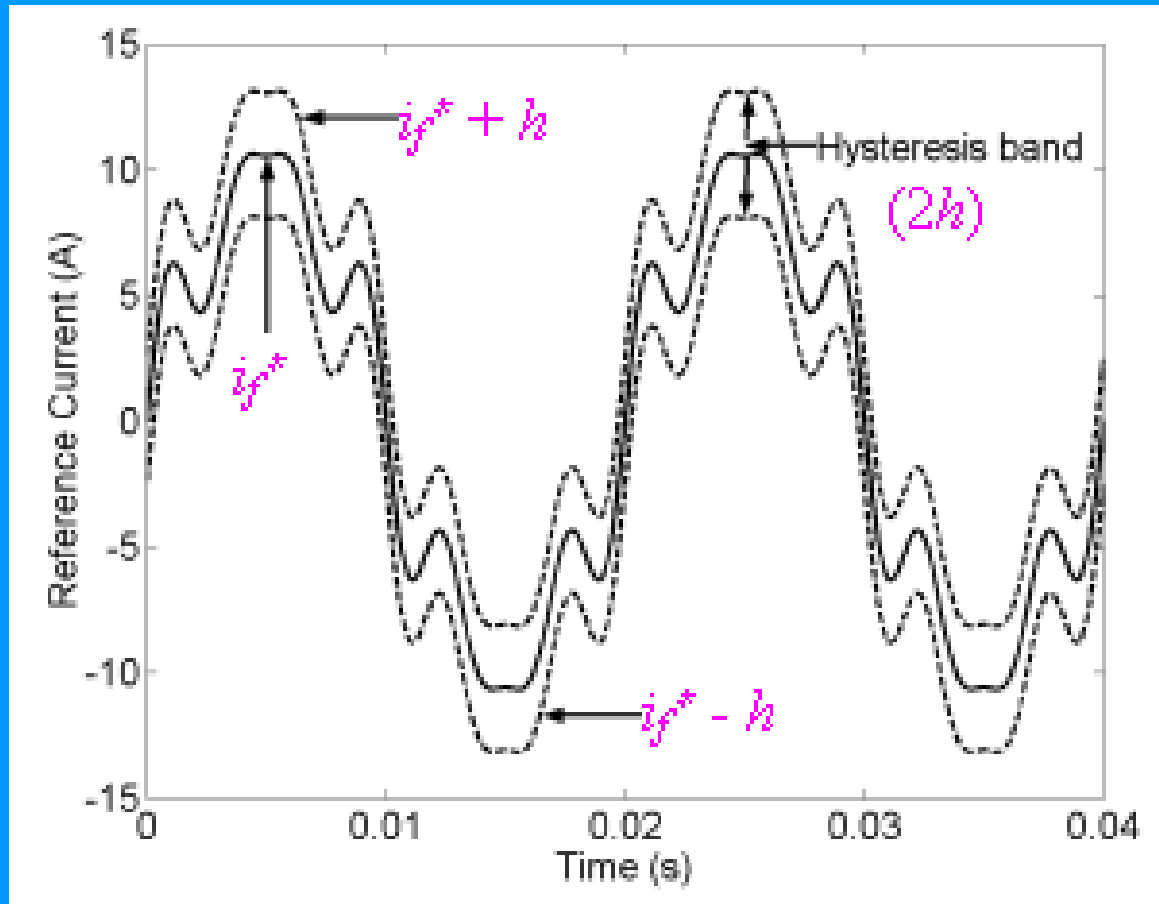

- The reference currents are tracked in a hysteresis band.

# DSTATCOM Operation

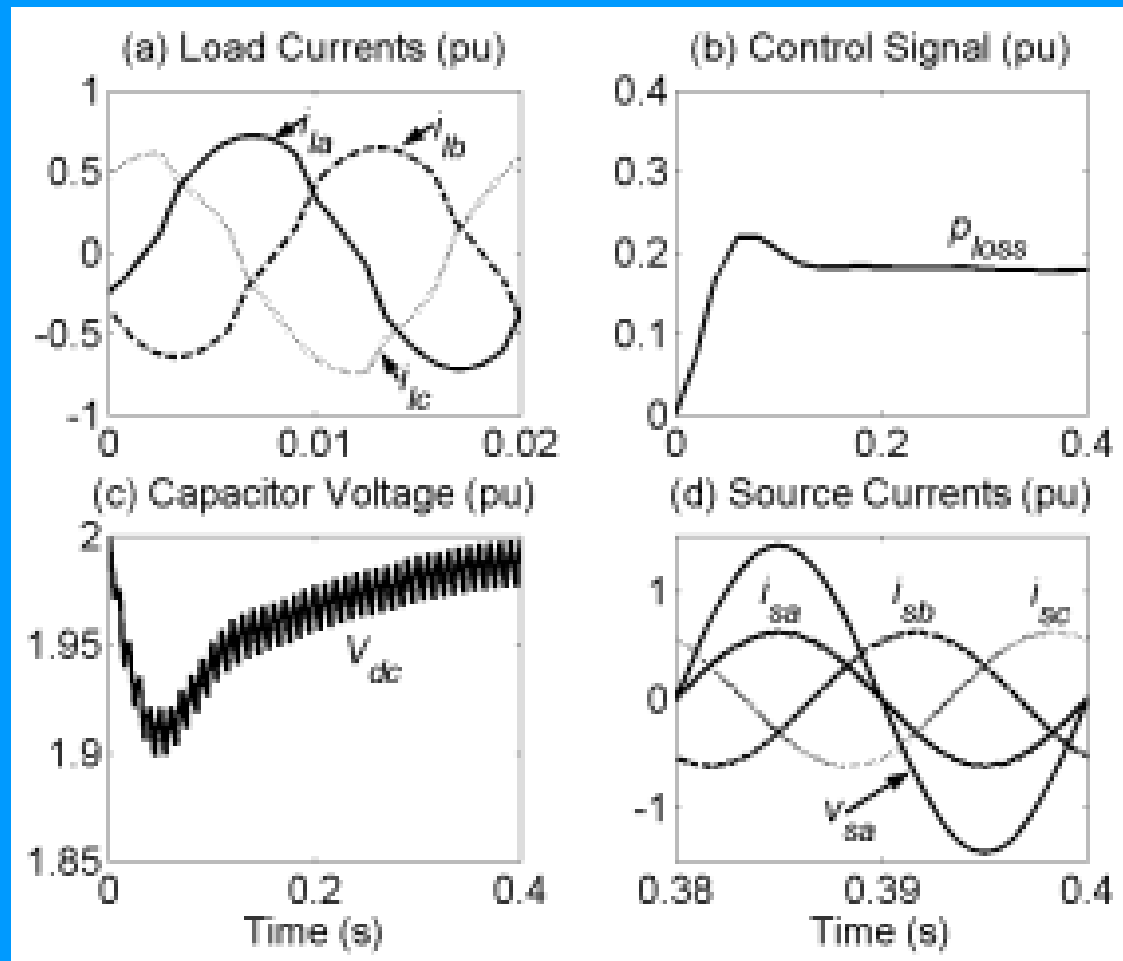

- Simulation results of the DSTATCOM operation.

# DSTATCOM Operation

Simulation

Experimental

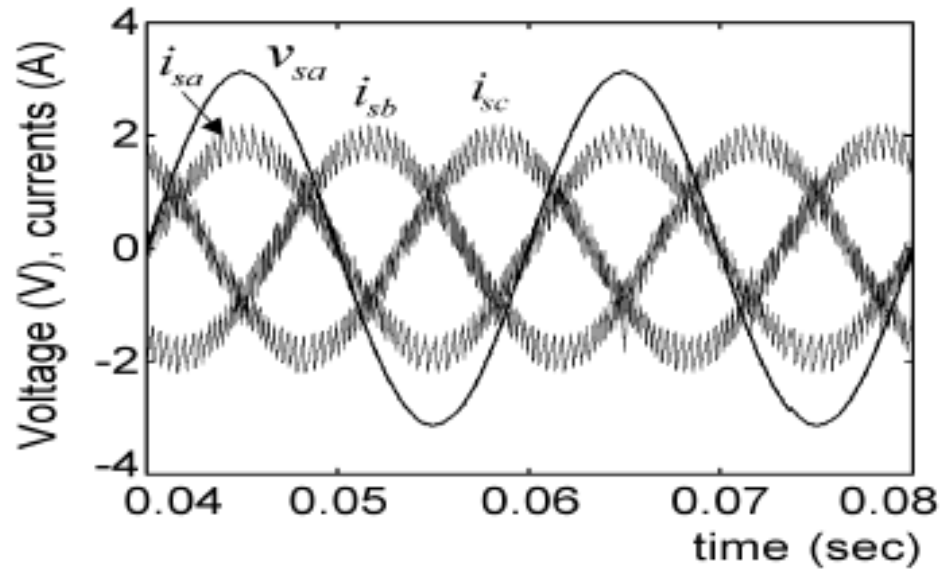

(a)

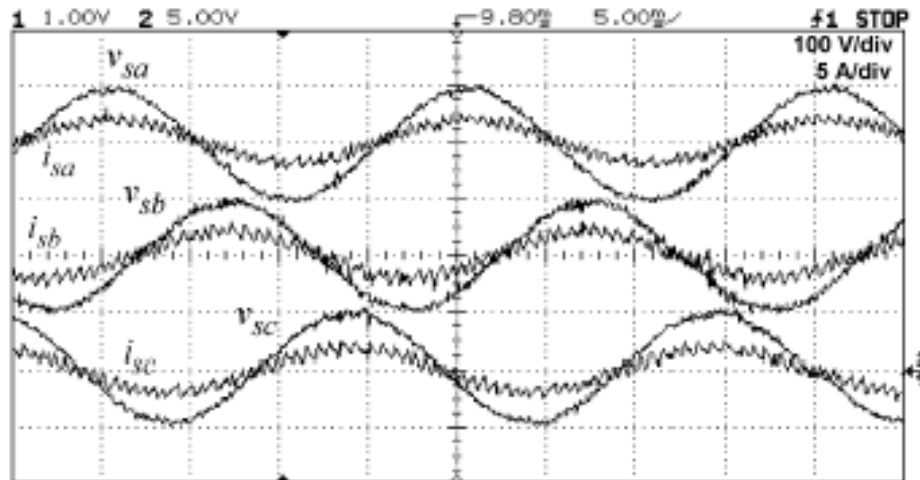

## DSTATCOM Connected to weak ac supply point

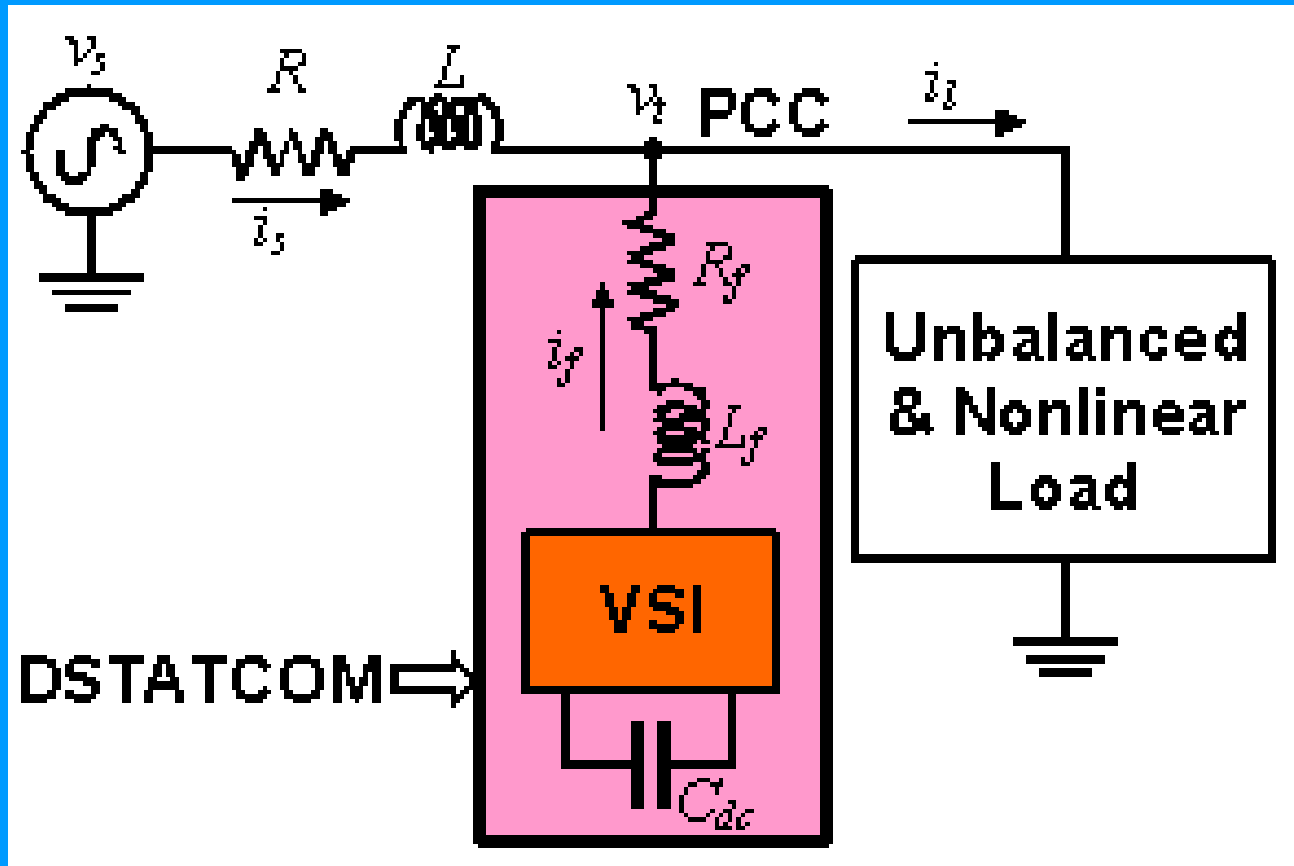

- The a load is supplied by a feeder.
- The DSTATCOM is connected at PCC (*terminal*) at the end of the feeder.

## DSTATCOM Connected to weak ac supply point

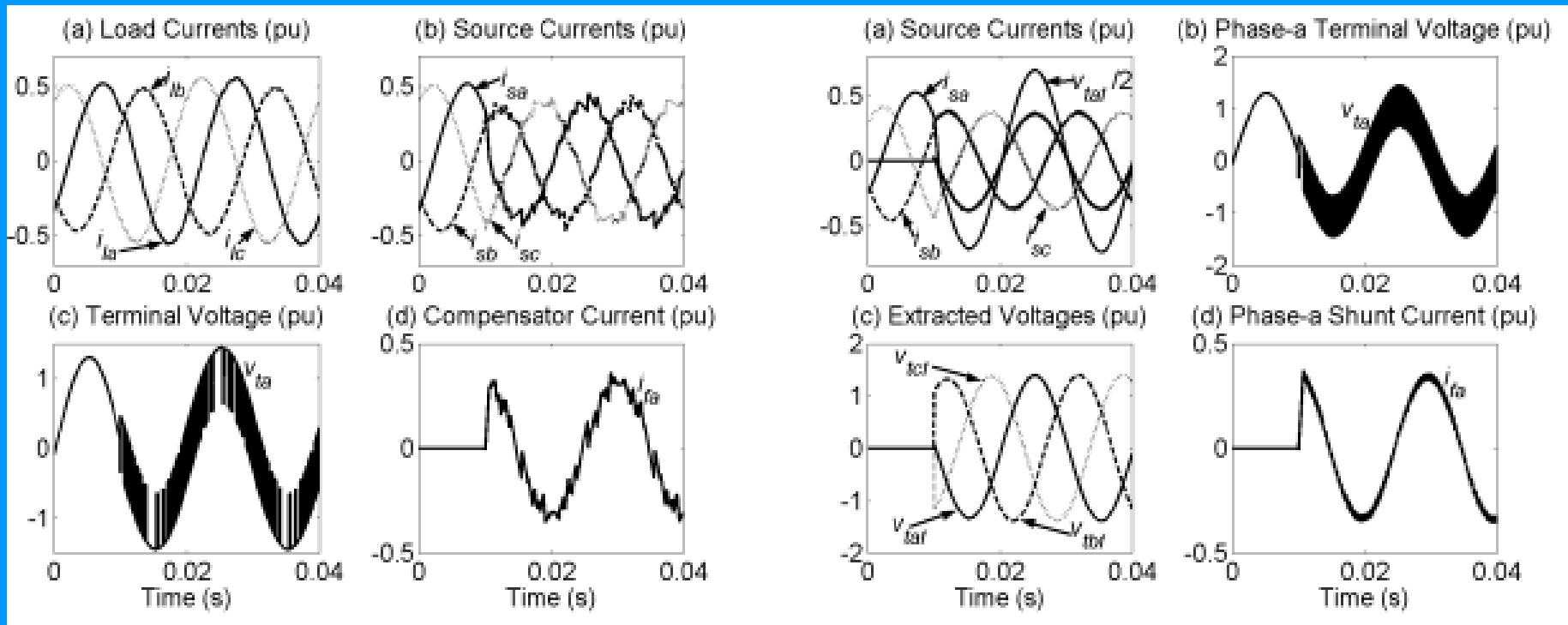

- The reference generation algorithm assumes balanced supply.
- The left figure shows when the measured terminal voltages are used and the right figure shows when fundamental voltages are used.

## DSTATCOM Connected to weak ac supply point

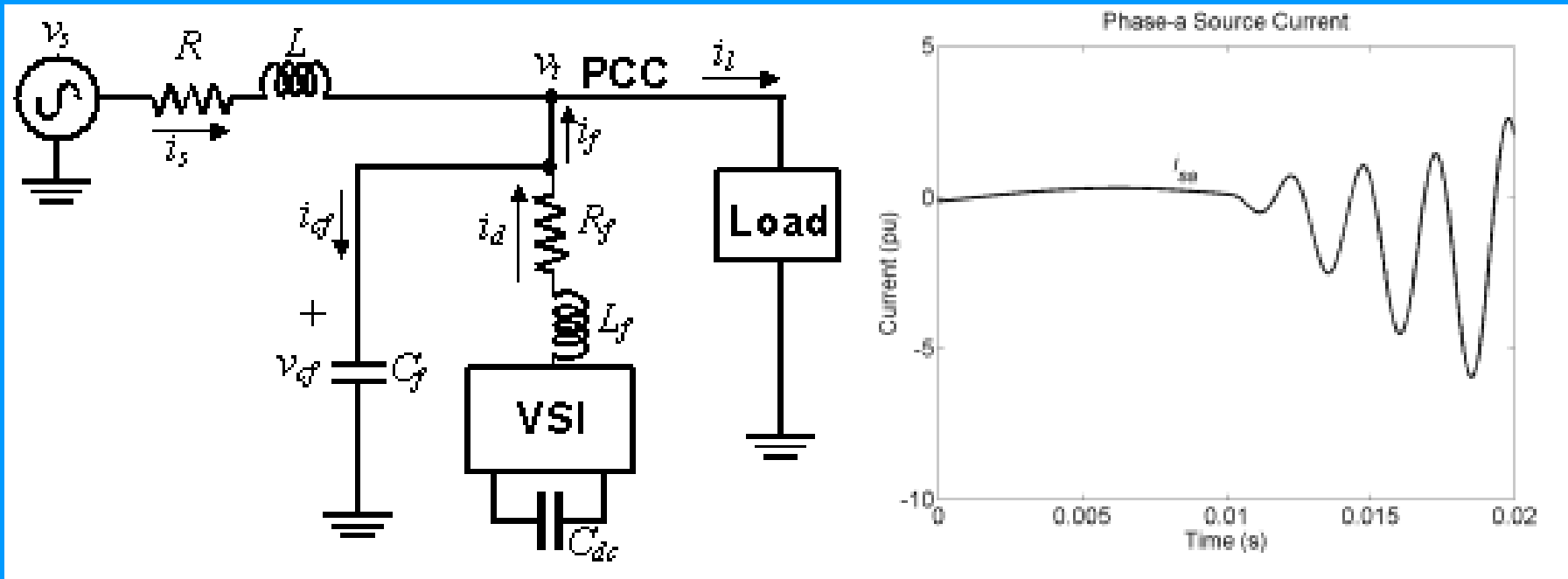

- To bypass the switch frequency harmonic generated, capacitor  $C_f$  is used (left).
- The hysteresis tracking of  $i_f$  results in an unstable feedback system (right).
- **Alternate control strategy required.**

## DSTATCOM – Switching Control

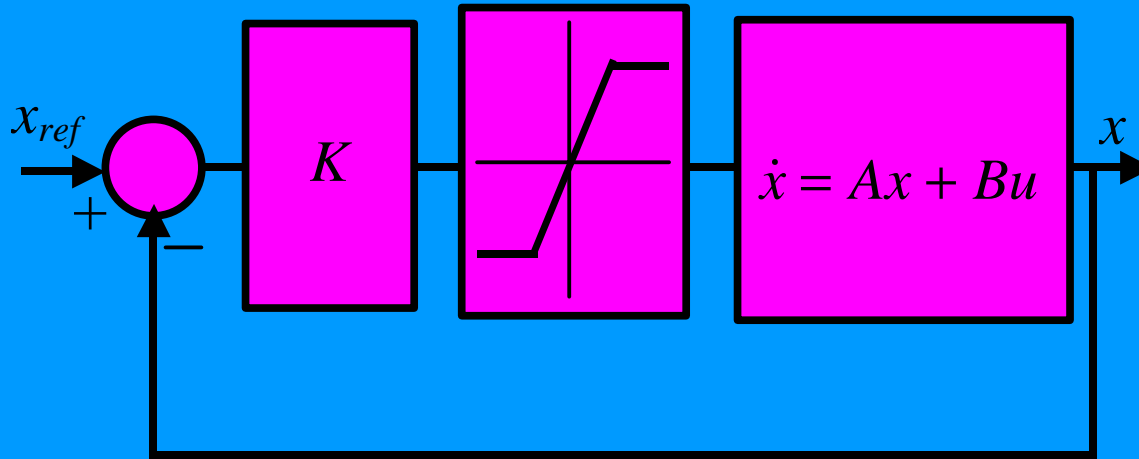

- One approach is state feedback control using linear quadratic regulator (LQR).
- This will require on-line generation of all the reference states.
- The LQR design is robust to parameter uncertainties.
- The output feedback approach is simpler but cannot guarantee stability.

## DSTATCOM – Performance for Non-Stiff Systems

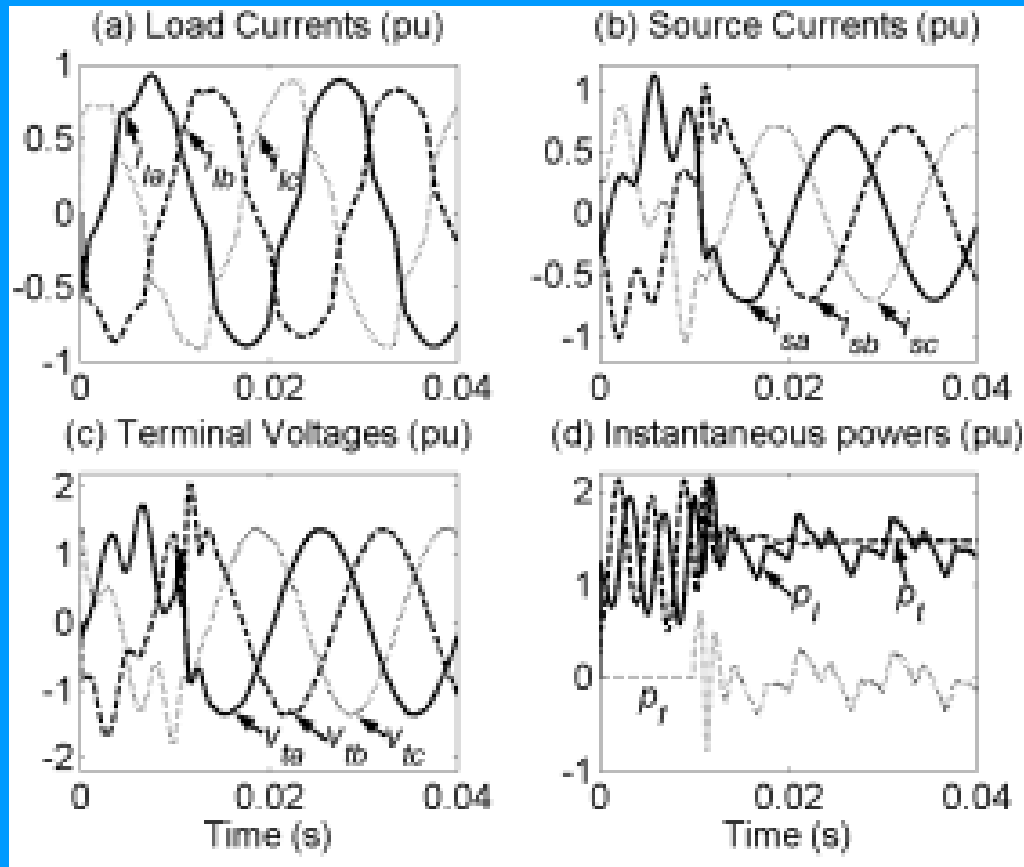

- With LQR control the source currents become sinusoidal.
- To achieve this, the PCC (terminal) voltages are forced to be sinusoidal.

# DSTATCOM – Performance for Non-Stiff Systems

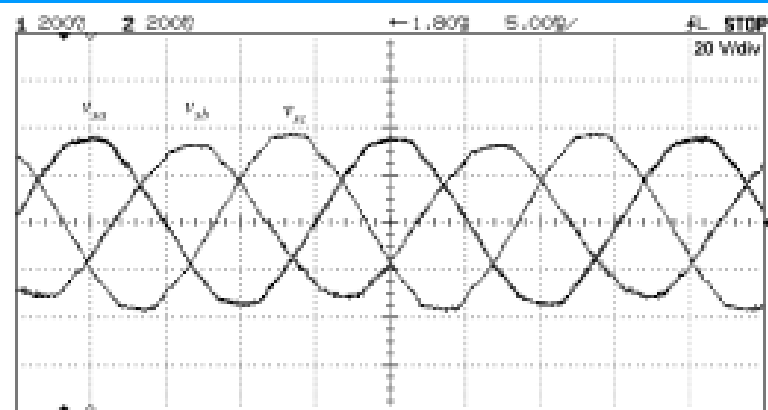

Source Voltages

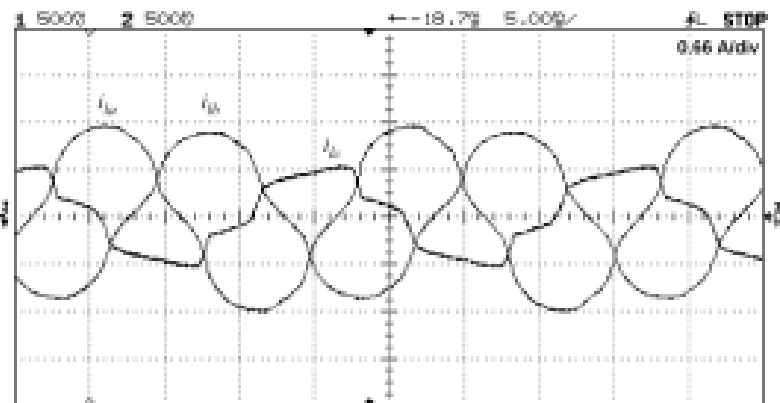

Load Currents

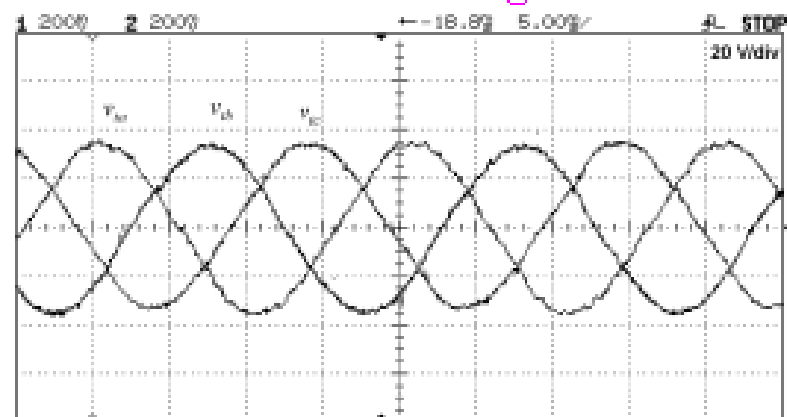

Compensated Terminal (PCC) Voltages

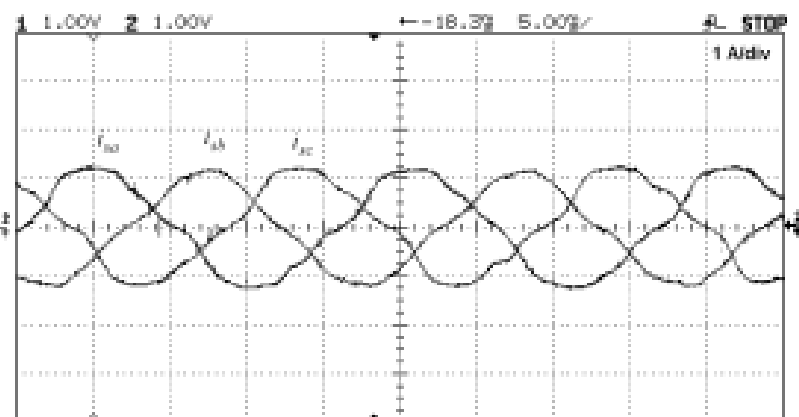

Compensated Source Currents

- The unbalance and harmonics in the source voltages get reflected in the source currents.

# DSTATCOM in Voltage Control Mode

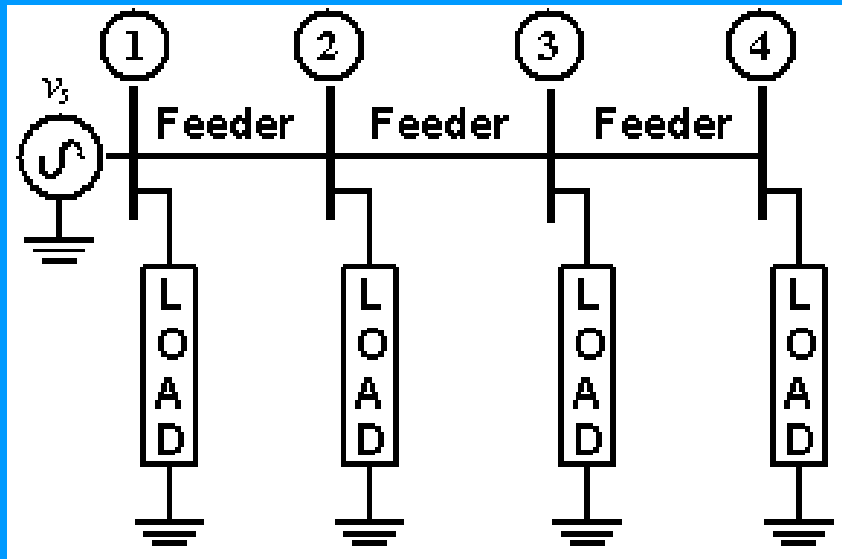

- Let us assume that we would like to correct the voltage of Bus-3.
- The Thevenin equivalent of the system looking at Bus-3 is the same as those shown in Slides 245 or 247.
- We can then use a state feedback or output feedback controller to hold the voltage of Bus-3.

## Voltage Control Mode – Reference Generation

- The magnitude of the bus voltage can be chosen arbitrarily.
- The phase angle ( $\delta$ ) should be controlled to ensure the power flow.
- Note that the dc capacitor must be able to supply the DSTATCOM while maintaining its voltage by drawing power from the ac system.
- Two PI controllers are designed in an inner power and outer voltage loop configuration.
- The outer loop regulates the dc voltage as

$$P_{shref} = K_p (v_{dref} - v_{dcav}) + K_I \int (v_{dref} - v_{dcav}) dt$$

## Voltage Control Mode – Reference Generation

- The inner loop set the angle by adjusting the power difference as

$$\delta = C_P (p_{shref} - p_{shav}) + C_I \int (p_{shref} - p_{shav}) dt$$

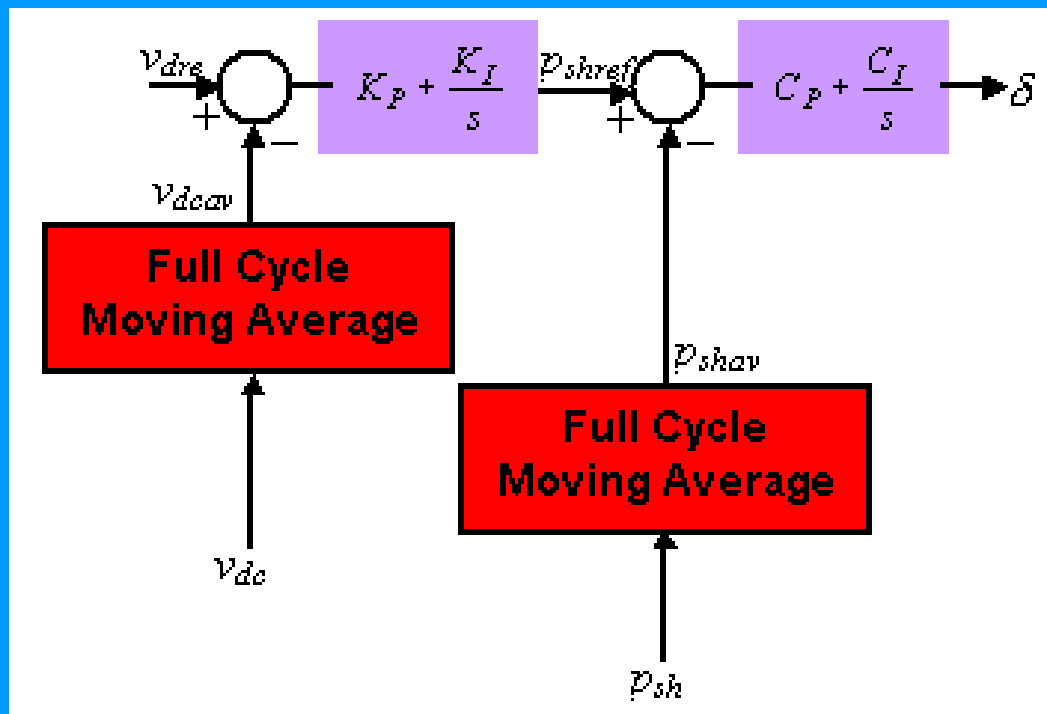

## Voltage Control Mode Results

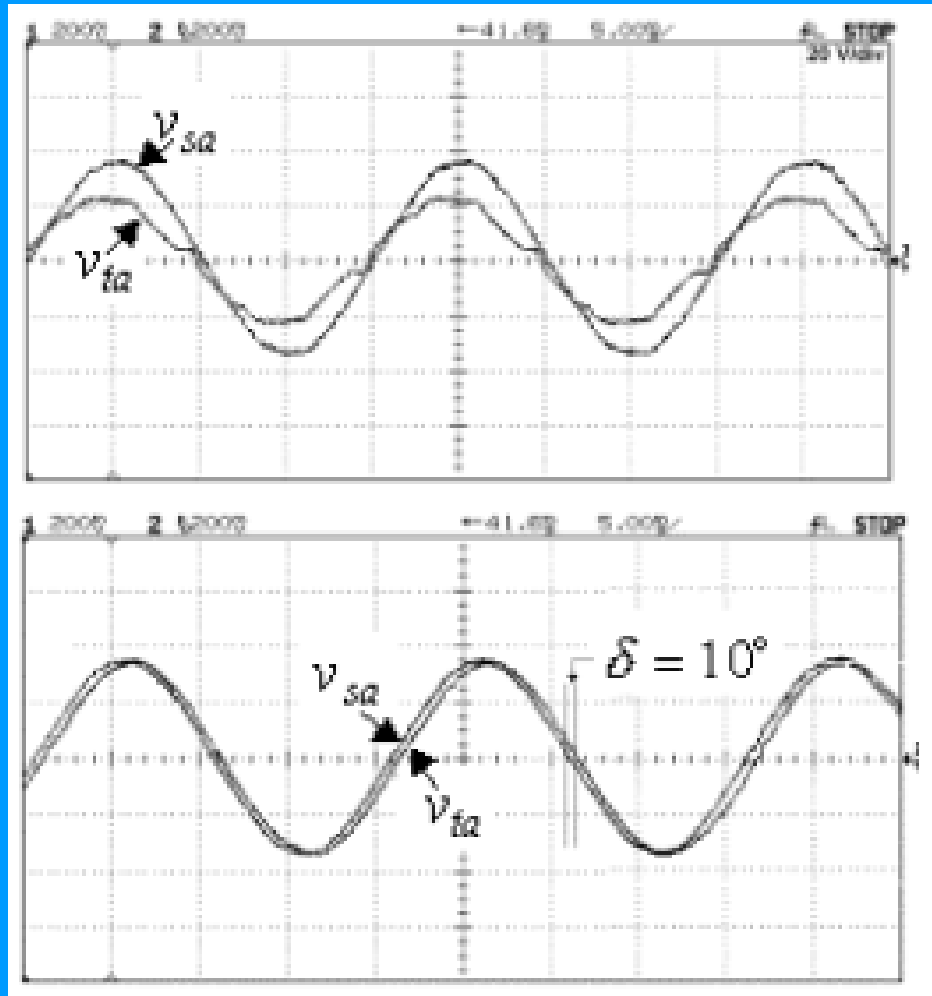

- The source is balanced but the load is unbalanced & distorted.
- The uncompensated bus voltage ( $v_{ta}$ ) is distorted (top trace).
- The compensated bus voltage ( $v_{ta}$ ) is distortion free (bottom trace).

## Voltage Control Mode Results

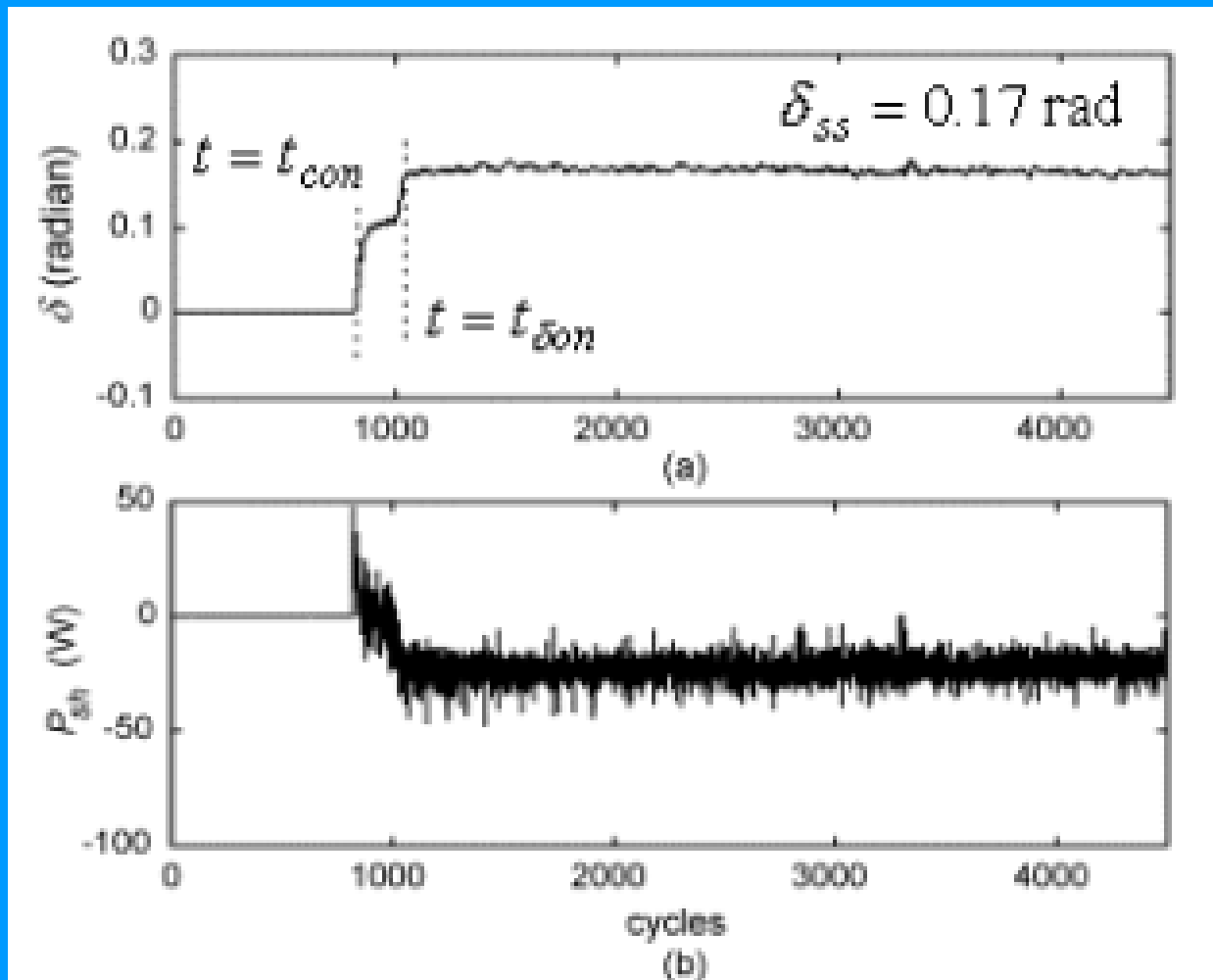

Load angle and power drawn from the ac system.

## Voltage Control Mode Results

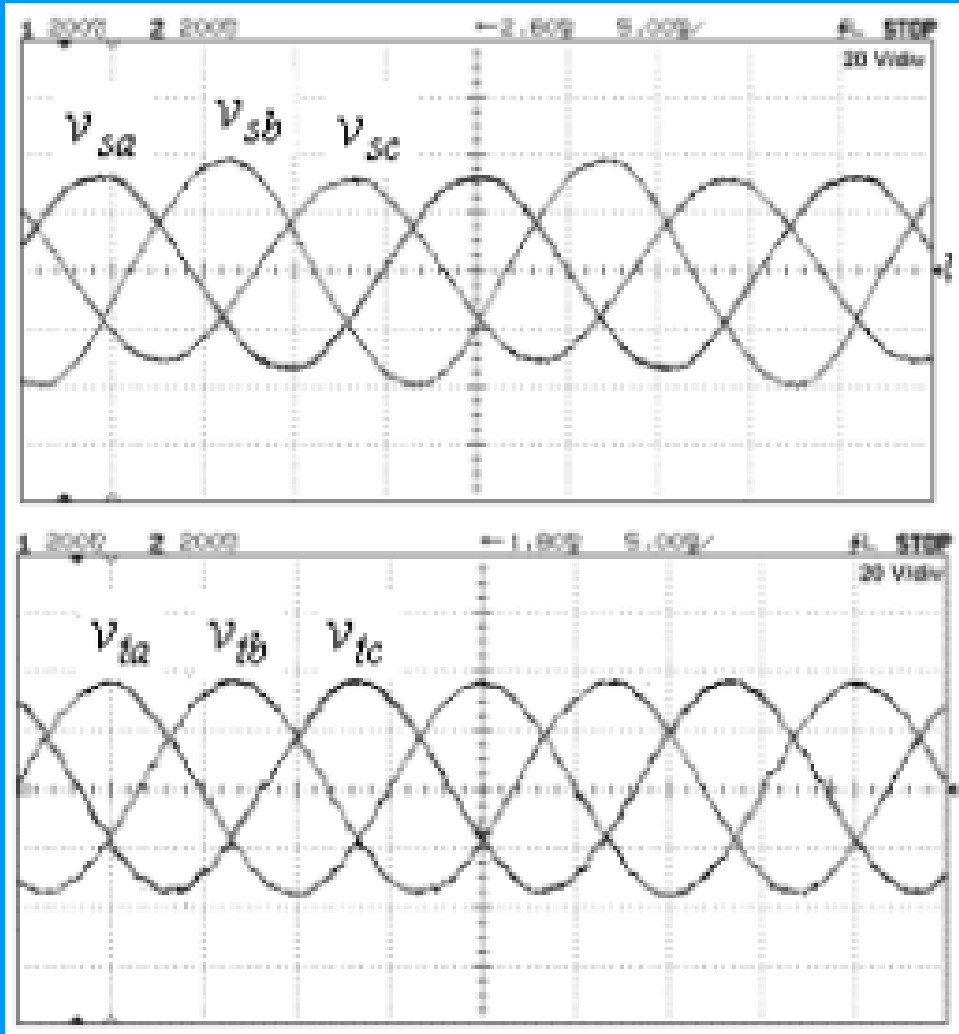

- The source voltages are unbalanced (top trace) and the load is both unbalanced and distorted.
- The DSTATCOM makes the bus voltages balanced (bottom trace).

# Dynamic Voltage Restorer (DVR)

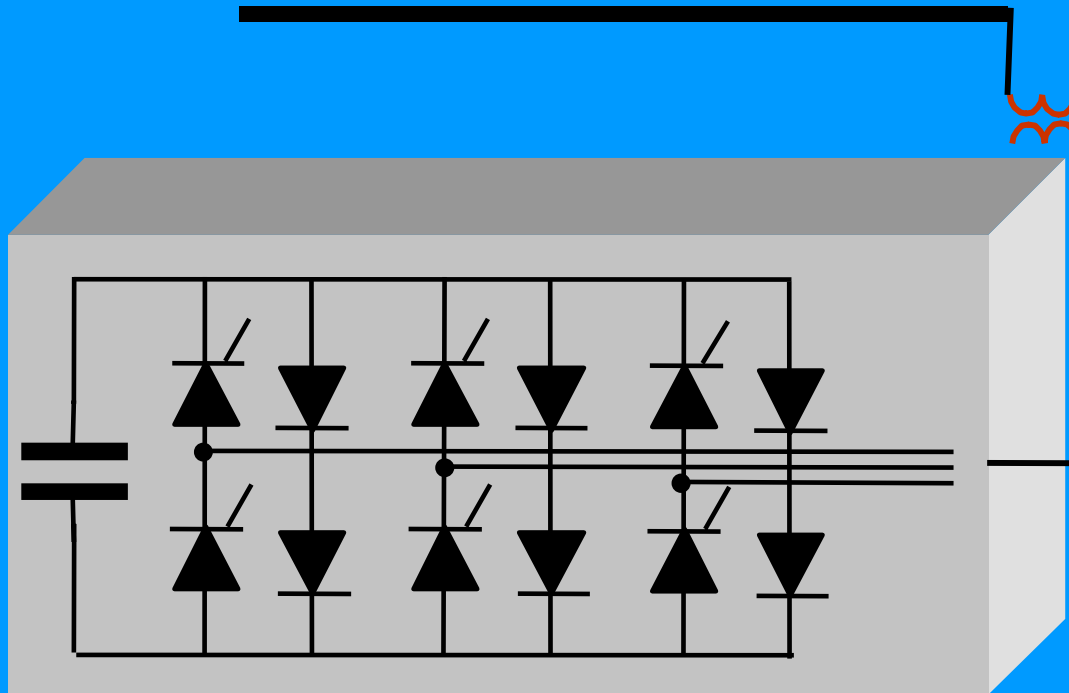

- A DVR is a series connected device.
- It protects sensitive loads from sag, swell or source voltage distortion.
- In addition, it can also tightly regulate the voltage at the load bus.

## DVR – Voltage Support

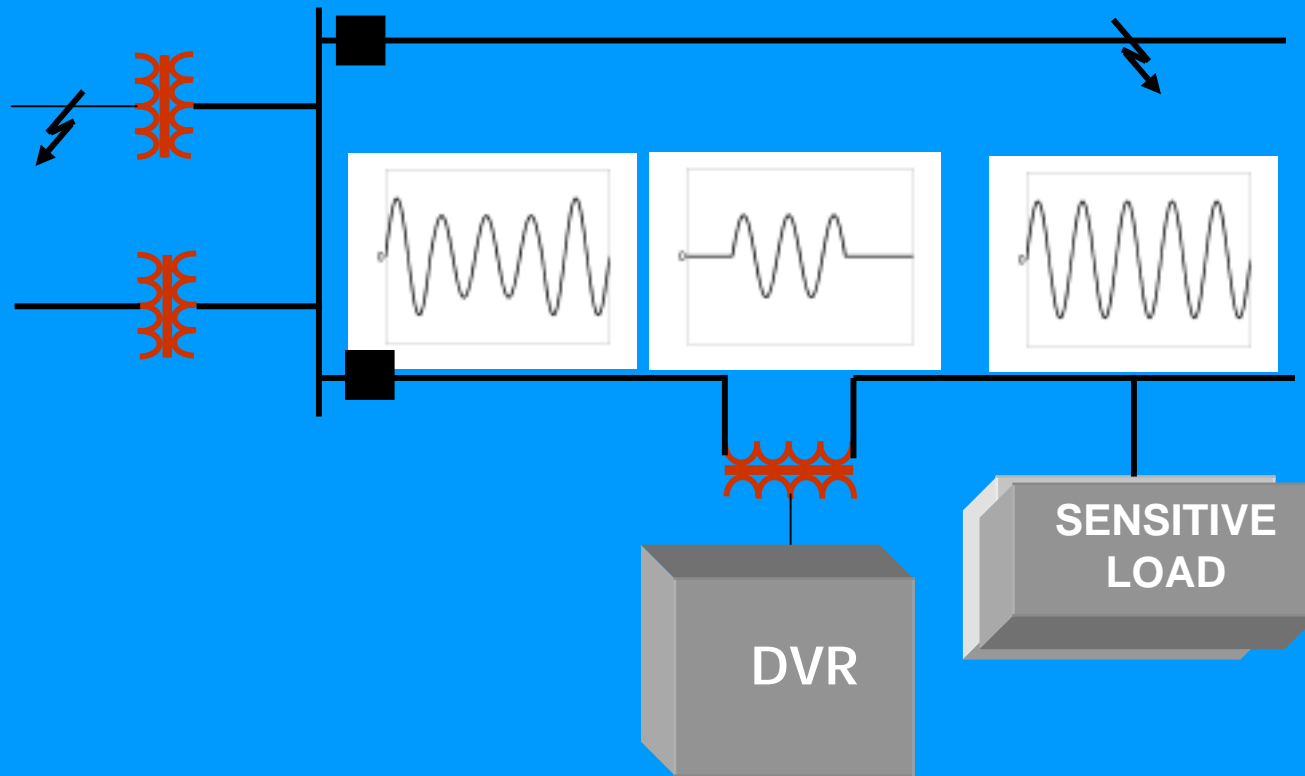

- A fault in either locations shown will results in a voltage sag in the feeder supplying the load.
- The DVR adds a voltage in series to offset the sag.

## DVR Installations

- In August 1996, Westinghouse Electric Corporation installed world's first DVR in Duke Power Company's 12.47 kV substation in Anderson, South Carolina to protect to an automated rug manufacturing plant.
- The next commissioning of a DVR was done by Westinghouse in February 1997 in Powercor's 22 kV distribution system at Stanhope, Victoria, Australia.
- This was done to protect a diary milk processing plant.
- The saving that may result from the installation of this DVR is estimated at over \$100,000 per year.
- The first ever platform mounted DVR was installed to protect Northern Lights Community College and several other smaller loads in Dawson Creek, British Columbia, Canada.

## The Study System

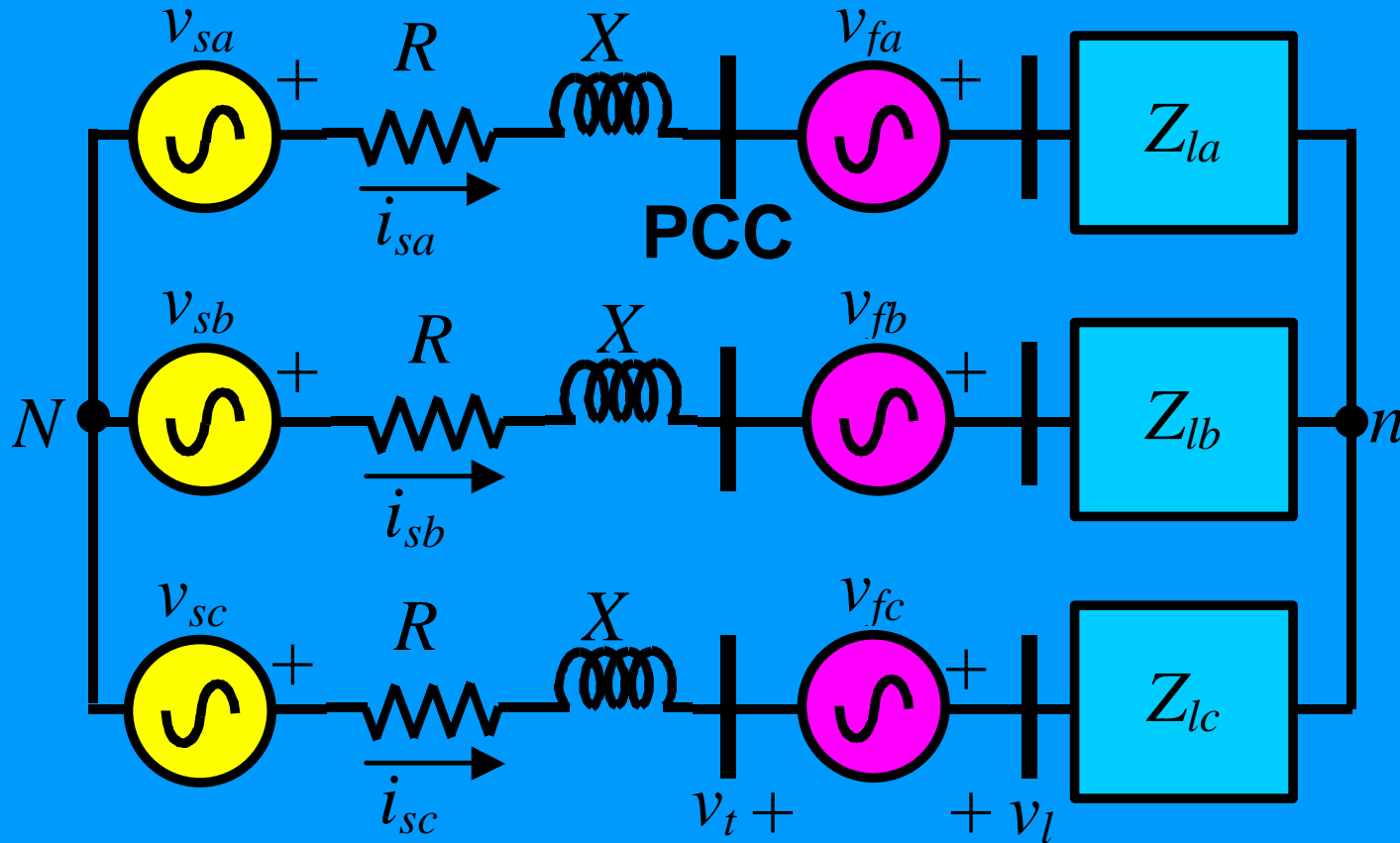

The DVR is represented by voltage sources  $v_{fa}$ ,  $v_{fb}$  and  $v_{fc}$ .

## DVR Structures

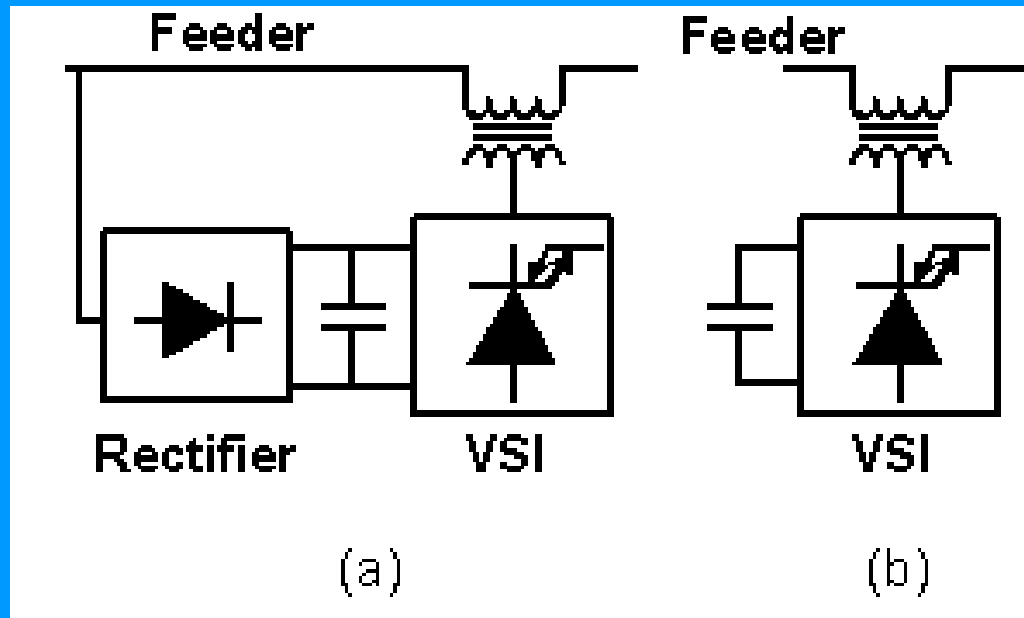

- The dc storage is one important issue in the DVR design.
- Schematic diagrams of (a) rectifier supported and (b) capacitor supported are shown.
- Other possibility is battery back up/support.

## Capacitor Supported DVR

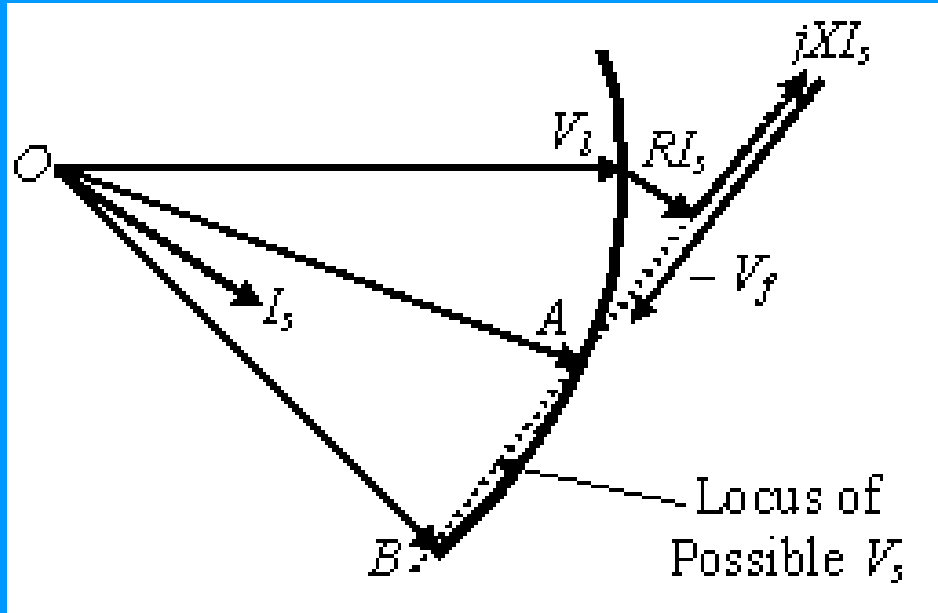

- The DVR should not absorb any real power in the steady state.
- Voltage injection must be in quadrature with line current

- Assume that source voltage and desired load voltage to be 1.0 per unit.
- Then the injection must be such that  $OA$  represent the source voltage.

# Capacitor Supported DVR

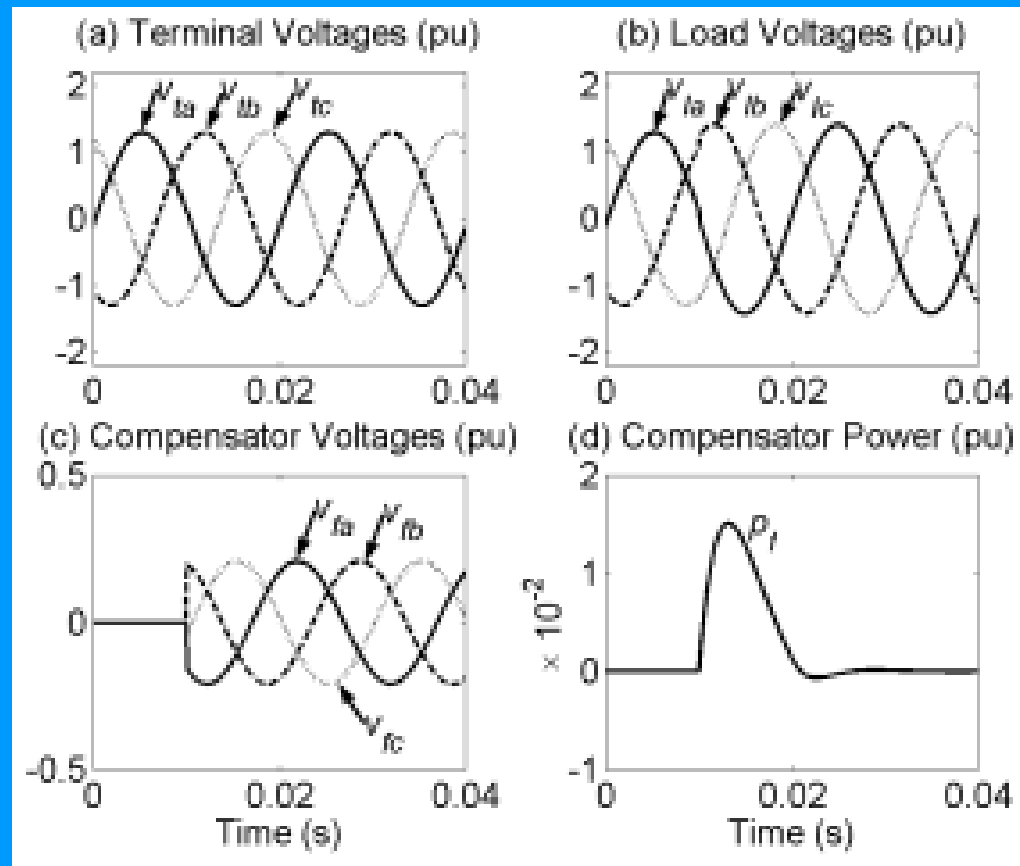

- The compensator power is zero in the steady state.



## Capacitor Supported DVR Limitations

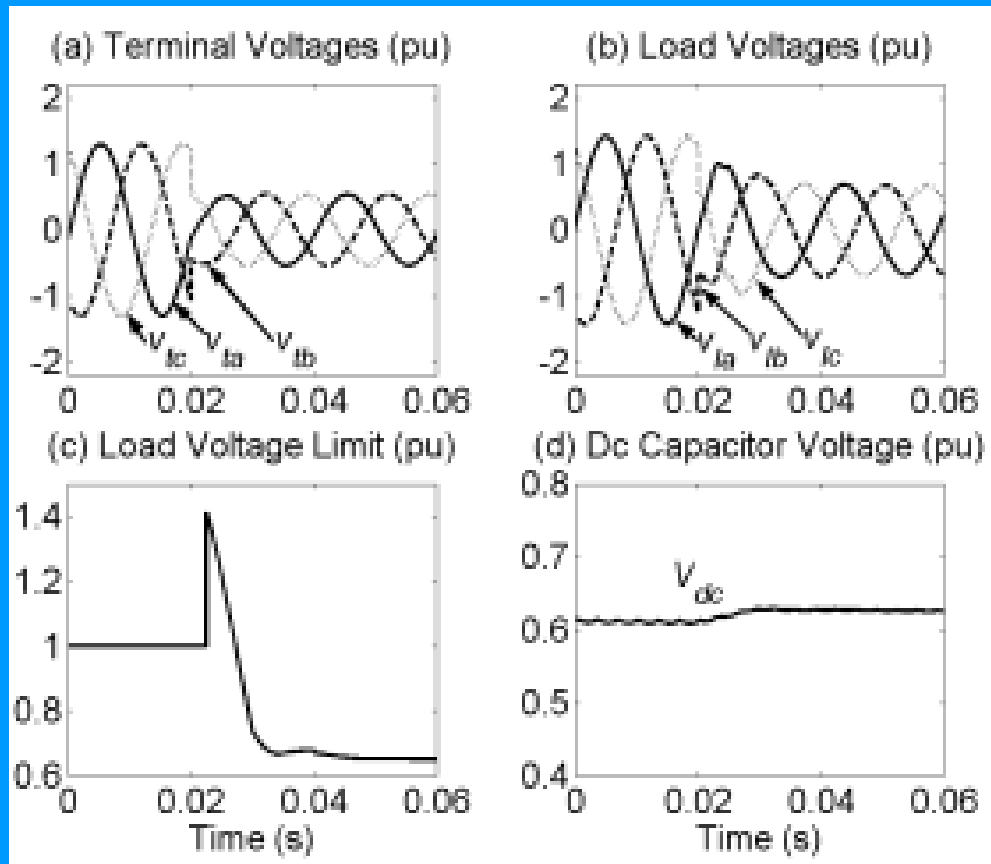

- Without active power exchange with the ac system, the capacity of the DVR to compensate a deep sag gets limited.

## Rectifier Supported DVR

- Power flow is unidirectional, i.e., from the rectifier to DVR and not the other way round.
- Difficult for the DVR to absorb power transiently.
- During deep sag, if the rectifier output capacitor voltage exceeds the peak of the input ac voltage, the rectifier will cut off.
- The rectifier generates harmonics at its input terminals.
- **Solutions: Use UPQC.**

# Unified Power Quality Conditioner (UPQC)

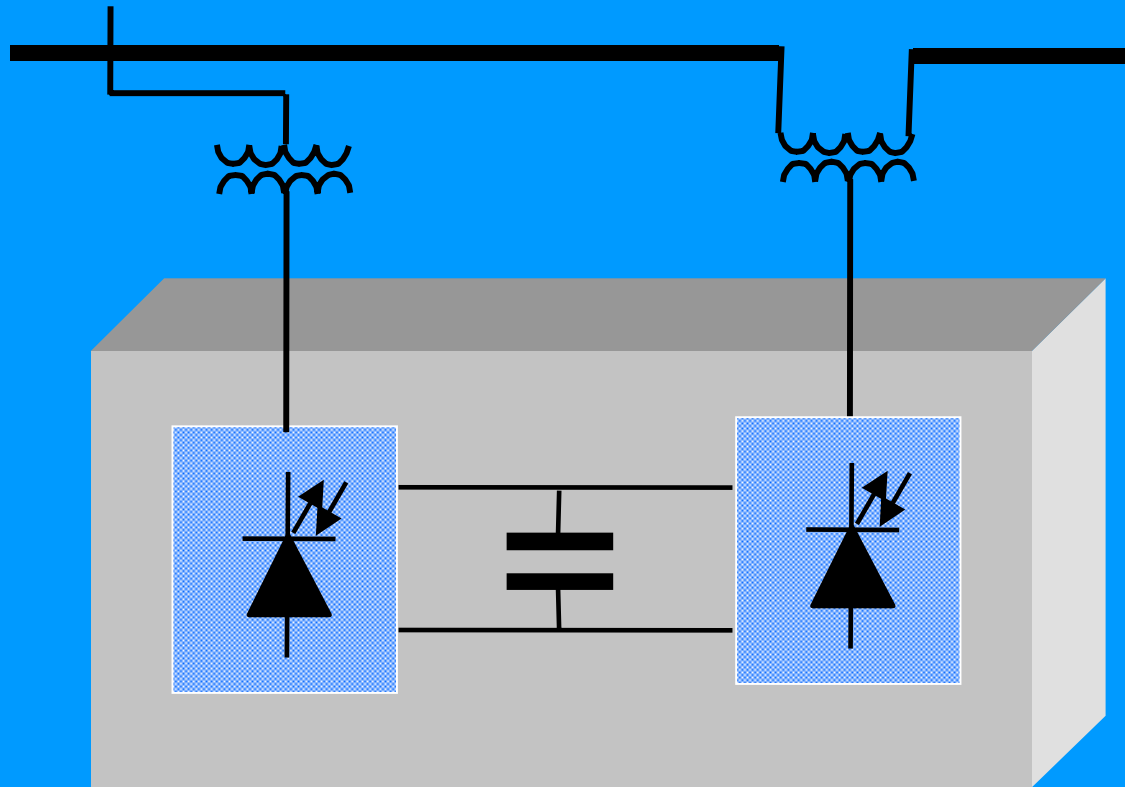

- A UPQC has a shunt inverter and a series inverter, both connected together through a dc storage capacitor.
- The dc capacitor facilitates power exchange between the two inverters.
- The UPQC can independently or jointly perform the tasks of both the series and shunt compensators.
- No much research done.
- Whether the device justifies its high cost.
- Possibly the star of the future.

# Custom Power Park

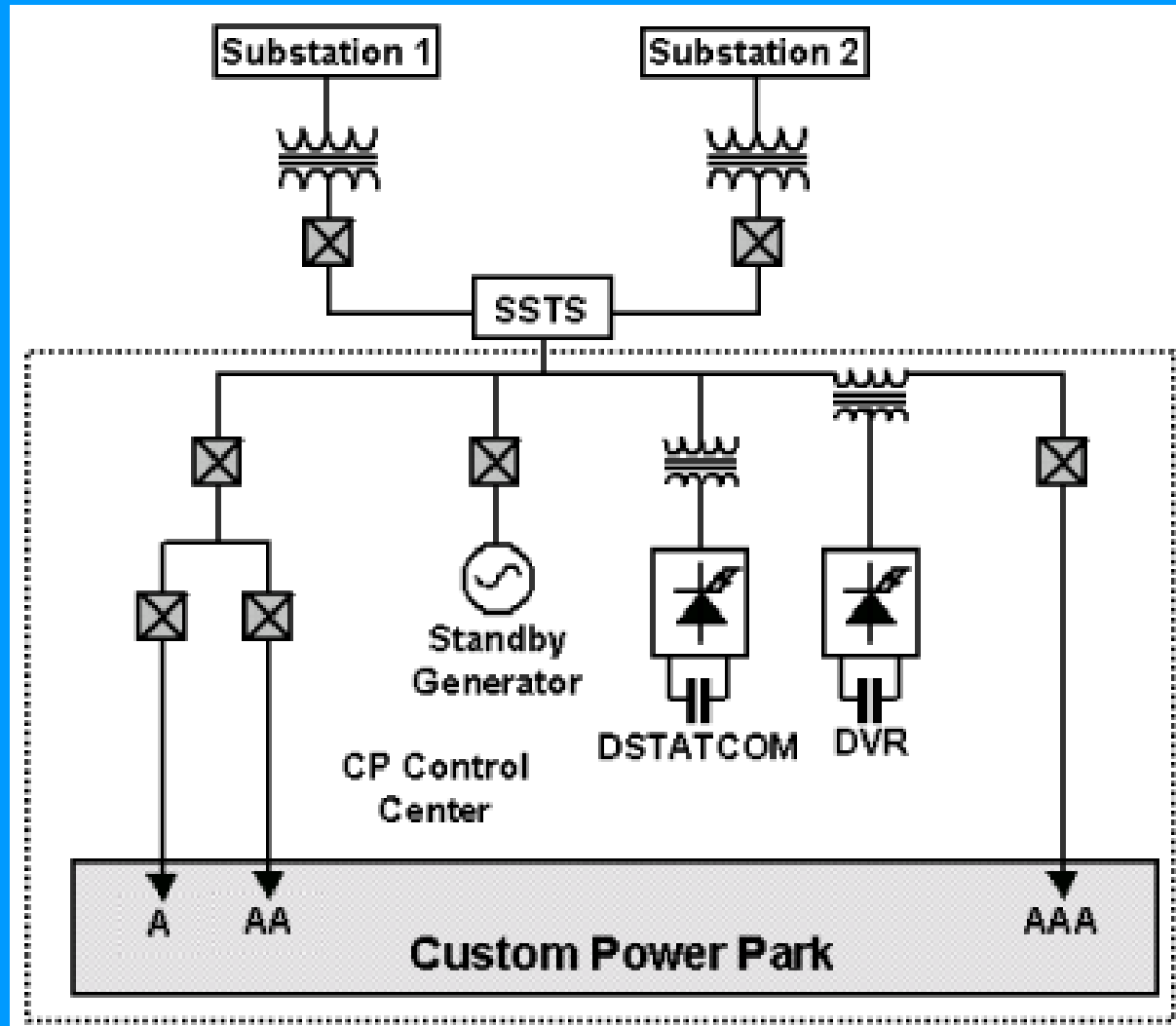

## Mini Custom Power Park

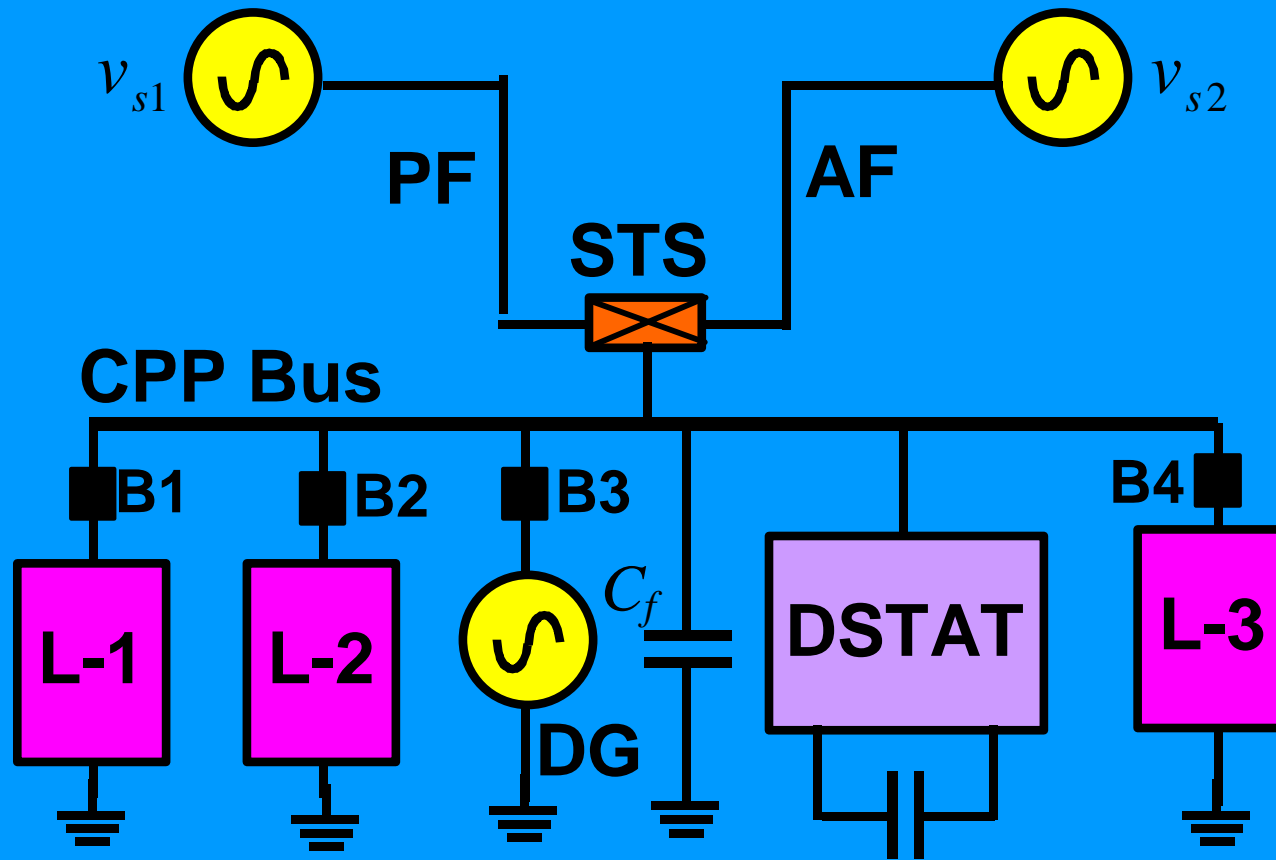

- STS is GTO based.
- B1, B2 are SCBs, while B3, B4 are mechanical.

## Mini Custom Power Park

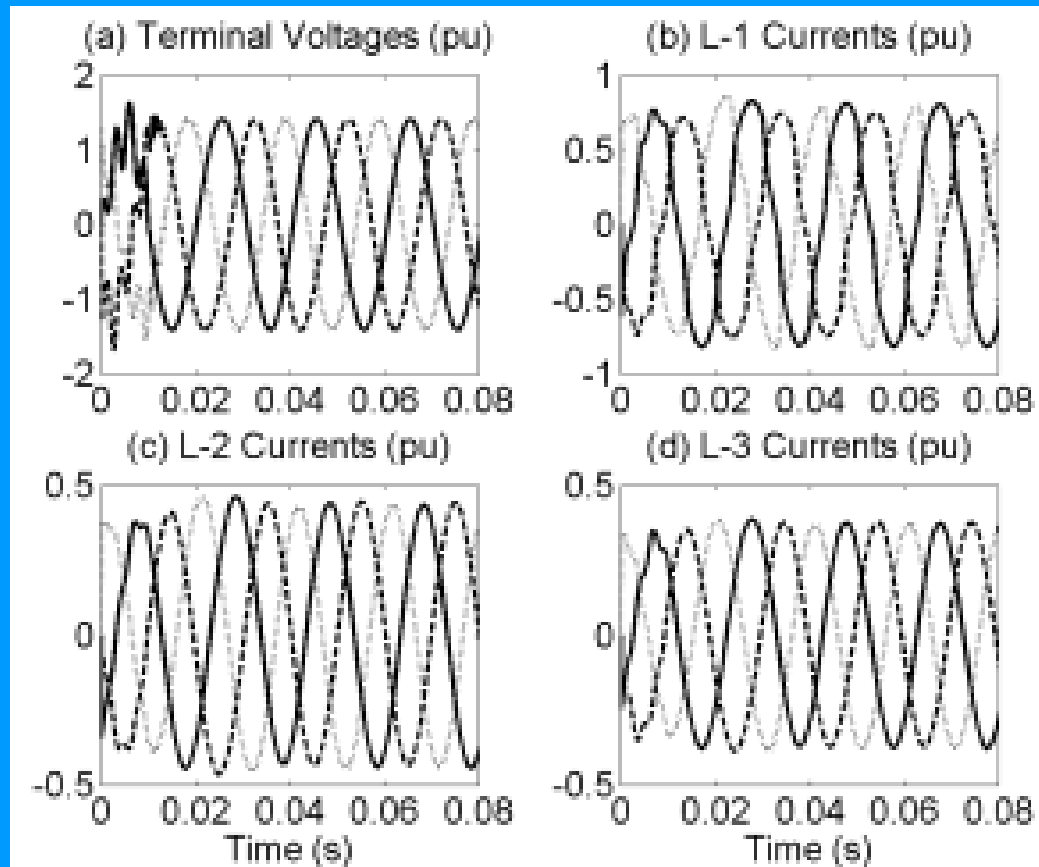

Loads L-2 and L-3 and the CPP bus voltage are balanced sinusoidal irrespective of L-1 being unbalanced and distorted.

**Thank you**