



Economic Impact Assessment of Transmission Enhancement Projects

Final Project Report

Power Systems Engineering Research Center

*A National Science Foundation
Industry/University Cooperative Research Center
since 1996*



Economic Impact Assessment of Transmission Enhancement Projects

Final Report

Project Team

**Shmuel Oren, Project Leader
University of California at Berkeley**

**George Gross
University of Illinois at Urbana-Champaign**

PSERC Publication 09-07

September 2009

Information about this project

For information about this project contact:

Shmuel Oren
The Earl J. Isaac Professor
Department of Industrial Engineering and Operations Research
4141 Etcheverry Hall
University of California at Berkeley
Berkeley, CA 94720
Phone: (510)642-1836
FAX: (510)642-1403
Email: oren@ieor.berkeley.edu

Power Systems Engineering Research Center

This is a project report from the Power Systems Engineering Research Center (PSERC). PSERC is a multi-university Center conducting research on challenges facing the electric power industry and educating the next generation of power engineers. More information about PSERC can be found at the Center's website: <http://www.pserc.org>.

For additional information, contact:

Power Systems Engineering Research Center
Arizona State University
577 Engineering Research Center
Box 878606
Tempe, AZ 85287-8606
Phone: 480-965-1643
FAX: 480-965-0745

Notice Concerning Copyright Material

PSERC members are given permission to copy without fee all or part of this publication for internal use if appropriate attribution is given to this document as the source material. This report is available for downloading from the PSERC website.

Acknowledgements

The Power Systems Engineering Research Center sponsored the research project titled “Economic Impact Assessment of Transmission Enhancement Projects (M-14).” We express our appreciation for the support provided by PSERC’s industrial members and by the National Science Foundation under grant NSF EEC-0119301 received under the Industry / University Cooperative Research Center program. Some of the work described in this report was partially supported by the Department of Energy through the Center for Electric Reliability Technology Solutions (CERTS).

Special thanks go to Jim Price at CAISO for his contributions to the research, and for his careful reading and thoughtful comments on this report.

Executive Summary

In this project, we propose a new methodological framework for assessing the economic impact of transmission investment. This framework improves on the current state of art by explicitly modeling strategic responses of generators to transmission investments. Using an economic measure of social benefit, results show that transmission planning should lead rather than follow generation investments. As a result, transmission investments should be treated as infrastructure development in the same general way that roadway investments are used for regional development. An example of such a policy is the Competitive Renewable Energy Zones in Texas for providing transmission that attracts wind generation investment to specific geographic areas. The project developed a game theoretic framework employing a three-stage game for assessing economic value of transmission projects. A paper resulting from this project won the Best Paper in Energy 2008 Award from the Institute for Operations Research and the Management Sciences.* Illustrations in the report help explain the motivation for model development and explain the results.

Development of a general analytic framework for the transmission network investment problem

We introduced a set of appropriate metrics to quantify the improvement attained from transmission investment in terms of welfare for all the participants. The use of these metrics in the evaluation of the impacts of new transmission investments under competition provides meaningful measures of the effects of a modification in the grid over a planning horizon. These measures are particularly useful in transmission planning because they allow for comparison of different transmission investment projects and enables prioritization of the projects. A key element of the proposed framework is the use of an optimization scheme to maximize the social welfare with and without the transmission asset investments under various bidding behaviors of the market players and contracting conditions. We illustrate the application of the proposed framework on the IEEE 24-bus RTS network.

Distributional Impacts, Market Power, and Alternative Economic Criteria for Transmission Investment

In general, transmission investment results in welfare transfers from load pocket generators and generation pocket consumers to load pocket consumers and generation pocket generators. However, load pocket consumers and generation pocket generators cannot simply decide to build a transmission line linking them. Their decision will be subject to scrutiny not only by a regional transmission operator (RTO) and possibly its stakeholder groups, but also by state and federal energy and environmental regulators. In this situation where there are winners and losers, the losers from the transmission investment might block the transmission investment even if it is socially beneficial. In this report, we present illustrative examples showing the diverse distributional impacts of transmission investments and the potential conflict between alternative economic criteria for investment decisions, such as consumer surplus maximization, effectiveness in curbing market power, and social surplus maximization. Furthermore, such decisions are very sensitive to a variety of parameters that could change over time. They also depend on the fuel cost advantage that some generation technologies have over other generation technologies.

The effect of market power on the market outcome of transmission expansion is a critical aspect often ignored in transmission planning. What might be a beneficial transmission project under the old regulated monopoly paradigm may not be so in a competitive environment where generation

* Enzo, Sauma; and Shmuel Oren. "Proactive Planning and Valuation of Transmission Investments in Restructured Electricity Markets." *Journal of Regulatory Economics*, Vol. 30, (2006), pp. 261-290.

and production decisions by profit-seeking generation companies may circumvent the potential economic benefits of a transmission project. We demonstrate with a simple two node example how interconnecting a cheap generation area with an expansive generation area may result in flow that is opposite to the expected direction (i.e., from the high cost to the low cost area) which reduces social welfare due to strategic response of generators with market power. The basic lesson from the above analysis is that transmission planning must account for stakeholder incentives and strategic interactions among market participants. The subsequent analysis and proposed methodologies are motivated by the above observations.

Incentives for Investments in Transmission Expansion/Enhancement

1) A Cooperative game approach to cost allocation and incentive design

The thrust of the work on this topic was to explore the development of an incentive mechanism for transmission asset investment. Incentives were designed to address the major challenges of underinvestment in transmission. The sluggishness of transmission construction is because mismatches between those benefitting from the new facilities and those paying for them often deter investment. We formulated the transmission investment problem in a cooperative game framework. Addition of new transmission assets can produce improvements in the network, such as congestion relief, that change the market efficiency. Cooperative game theory allows participants to jointly create added value and to receive compensation based upon the individual contribution to the welfare of the system. We proposed an incentive mechanism where the players of the cooperative game were the investors in transmission assets. A planning authority reimbursed these investors by offering them all or part of the social welfare increase brought by their investment. If their return requirements were below the incentives, then they were invited to invest. The entire process was iterative until there were no more investors willing to invest in new transmission assets. We tested the proposed methodology on two systems – the Garver 6-bus system and the 24-bus IEEE Reliability Test System. The results provided useful insights and a solid basis for further testing on larger networks.

2) The effect of FTR allocation on transmission investment incentives

We studied whether generators have the incentive to fund or support incremental social-welfare-improving transmission investments. In particular, we examined how such incentives were affected by the ownership of financial transmission rights (FTRs) by generators. In the context of a two-node network, we showed both (i) that the net exporting generator has the correct incentives to increase the transmission capacity incrementally up to a certain level and (ii) that, although a policy that allocates FTRs to the net exporting generator can be desirable from a social point of view, such a policy would dilute the net-importer-generator's incentives to support transmission expansion. Moreover, if all FTRs were allocated or auctioned off to the net exporting generator, then it is possible to increase both consumer surplus and social welfare while keeping the net exporting generator revenue neutral.

Proactive Planning and Economic Impact Assessment of Transmission Expansion

The interactions between the transmission and the generation systems are a crucial element in the analysis of the optimal way to expand a network. In principle, the true value of transmission is reflected by the gain from trading among interconnected regions. Yet, due to the physical laws of electricity, there are both operational and investment complementarities and substitutabilities between generation and transmission assets. If a generator creating congestion in a line were to expand its generation capacity in order to gain more of the equilibrium market share, this would aggravate the congestion over the line and would increase the value of additional transmission capacity. At the same time, if a generator providing counterflow to the previous line were to expand its generation capacity, then this would result in a decreased transmission value. Market

power plays a key role in this context since it will affect how generators respond to transmission investment while seeking to maximize their profit. Such responses may enhance or negate the contribution of transmission investment to social welfare.

We proposed a three-period model to examine how the exercise of local market power by a generator affects both the generating firms' incentives to invest in new generation capacity and the equilibrium investment between the generation and the transmission sectors. The model structure was a social welfare maximization problem subject to market equilibrium constraints characterized as a two-stage equilibrium problem. Under this paradigm, the network planner optimizes the expansion plan while accounting for subsequent generation capacity expansion and the energy spot market outcome.

As a benchmark, we used an idealized (but impractical) integrated resource planning process that co-optimizes investment in transmission and generation so as to maximize social welfare. We considered both a fully vertically integrated social planner (FVISP) who both optimized investment in transmission and generation, and operates the resources in real time to maximize social welfare versus an integrated resource planner (IRP) who optimized investment while anticipating the strategic interaction of the privately owned generation firms in the energy market.

We then show that a "proactive" system operator - PSO (who plans transmission investments in anticipation of generation investments so that it is able to induce a more socially-efficient Nash equilibrium of generation capacities) can recoup some of the welfare lost due to the unbundling of the generation and the transmission investment decisions by proactively expanding transmission capacity. Conversely, we show that a "reactive" system operator - RSO (who plans transmission investments only considering the currently installed generation capacities and, in this way, ignoring the interrelationship between the transmission and the generation investments) foregoes this opportunity and may make suboptimal investment decisions.

The results are illustrated using a 30-bus test case. The results suggest that transmission planning should be done with a centralized regional planning perspective that accounts for all subsequent decentralized decisions by stakeholders in the investment and operations stages of a market and attempts to influence these decisions. This view represents a departure from the "generation centric" approach that favors decentralized merchant driven transmission planning and view the role of transmission expansion to provide interconnection services in response to investment decisions by generators.

Table of Contents

1.	Introduction.....	1
2.	Development of a General Analytic Framework for the Transmission Network Investment Problem	8
	2.1 Conceptual framework.....	8
	2.2 Documentation.....	11
3.	Distributional Implications and Alternative Valuation Criteria for Transmission Investments	12
	3.1 Diverse distributional impact of transmission investment.....	12
	3.2 Conflicting planning objectives	14
	3.3 Adverse interaction of market power and connectivity	19
	3.4 Policy implications.....	21
	3.5 Documentation.....	22
4.	Investment Incentives for Transmission Investment and Cost Allocation	23
	4.1 A cooperative game approach to incentivizing transmission investment....	23
	4.2 Aligning stakeholders incentive with the social objectives through FTR allocation.....	27
5.	A Proactive Planning Paradigm for Economic Assessment of Transmission Expansion Projects.....	30
	5.1 The proactive transmission investment model.....	31
	5.2 Transmission investment models comparison	37
	5.3 Case study	41
	5.4 Documentation.....	50
6.	Conclusions and Recommendations	51
7.	References.....	53

List of Figures

Figure 1: The four-layer framework structure.....	9
Figure 2: The IEEE 24-bus reliability test system topology	10
Figure 3: An illustrative two-node example	14
Figure 4: Effects on consumers and producers of building a non-binding-capacity line between both nodes, assuming that the investment cost is negligible	18
Figure 5: Sensitivity to the marginal cost of supply at node 1 in the two-node network	18
Figure 6: Equilibrium at node 1 under both the SSNS and the NBTCS	20
Figure 7: Equilibrium at node 2 under both the SSNS and the NBTCS	20
Figure 8: Best response functions.....	28
Figure 9: Three-period model for proactive transmission investment	31
Figure 10: 30-bus Cornell network.....	42
Figure 11: Results of the PSO model in the normal state, under absence of transmission investment, for the 30-bus Cornell network	47

List of Tables

Table 1:	Electric characteristics of the transmission lines of the 30-bus Cornell network	43
Table 2:	States of contingencies associated to the energy market operation	44
Table 3:	Nodal information used in the 30-bus Cornell network in the normal state of contingency.....	44
Table 4:	Generation quantities, adjustment quantities, and nodal prices in normal state, in the PSO model, under absence of transmission investments.....	46
Table 5:	Assessment of single transmission expansions under the PSO model	47
Table 6:	Assessment of single transmission expansions under the RSO model	48
Table 7:	Assessment of single transmission expansions under the IRP model.....	49
Table 8:	Assessment of single transmission expansions under the FVISP model	50

1. Introduction

Over the past two decades, many countries – including the US – have restructured their electric power industries from the traditional vertically integrated regulated monopolies to a market-based vertically- unbundled structure. In the vertically-integrated monopoly structure, planning and investment in generation and transmission assets, as well as operating procedures were closely coordinated through an integrated resource planning process that accounted for the complementarity and substitutability of the different resources in meeting the reliability and the economic objectives. The separation of the generation and transmission sectors has resulted in a new paradigm for operations and planning, where the planning of and the investment in generation assets are driven by purely economic considerations in response to market prices and incentives. The transmission network, on the other hand, is operated by an independent transmission organization that may or may not own the transmission assets. Whether the transmission system is owned by the system operator, as in the UK, or by various owners as in many ISO/RTOs in the US, the system operator bears overall responsibility for assessing the needs for transmission enhancements from both a reliability and an economic perspective and in evaluating proposed transmission projects. As the operating and the investment decisions of the generation companies are market driven, the valuation of transmission projects must appropriately incorporate the impacts of such investment decisions on market outcomes, including demand response. Market prices are influenced by a variety of factors, such as concentration and ownership pattern of the generation assets, the nature of the constraints in the grid, the distribution and price elasticity of demand, demand uncertainty and, quite significantly, the set of specified contingencies for security evaluation.

Vertical unbundling of the electricity industry and the reliance on market mechanisms for pricing and return on investments have increased the burden of economic justification for investment in the electricity infrastructure. The role of regional assessment of transmission expansion needs and approval of proposed projects has shifted in many places from the integrated utility to a regional transmission organization (RTO), which is under the jurisdiction of the Federal Energy Regulatory Commission (FERC), while the funding of such projects through the regulated rates is still under the jurisdiction of state regulators. In evaluating the economic implications of transmission expansions the RTO and state regulators must take into considerations that, in a market-based system, such expansions may create winners and losers, even when the project as a whole is socially justifiable on the grounds of reliability improvements and energy cost savings. Furthermore, in the new environment, transmission expansion may be also justified as a mean for facilitating free trade and as a market mitigation approach to reducing locational market power.

The experience to date in the US indicates that virtually all the regulatory approved transmission enhancement projects are driven by reliability needs and interconnection requirements of new resource additions. The focus, however, of this proposal is on the development of a practical methodology for assessing the economic worth of

transmission projects. Such assessments are needed to identify winners and losers (in the economic sense) among the proposed projects and for identifying investments that, while not absolutely essential from a reliability perspective, have economically beneficial impacts on markets by facilitating additional transactions and thereby enhancing efficiency in market operations. The Federal Energy Regulatory Commission (FERC) has recently recognized in Order 890 the expanded role of transmission as a market enabler and endorsed the possibility of transmission expansions that are motivated by market benefits in addition to reliability driven expansion.

From an economic theory perspective, the proper criterion for investment in the transmission infrastructure is the maximization of social welfare, which is composed of consumers' and producers' surplus, which also accounts for investment cost and may account for reliability by including the social cost of unreliability in this objective function. When demand is treated as inelastic, social welfare maximization is equivalent to total cost minimization including energy cost, investment cost and cost of lost load or other measure of unreliability cost. The validity of this economic objective is premised on the availability of *adequate and costless* (without transaction costs) transfer mechanisms among market participants, which assures that increases in social welfare will result in Pareto improvements (making all participants better off or neutral).

However, this principle is not always true in deregulated electric systems, where transfers are not always feasible and even when attempted are subject to many imperfections. In the U.S. electric system, which was originally designed to serve a vertically integrated market, there are misalignments between payments and rewards associated with use and investments in transmission. In fact, while payments for transmission investments and for its use are made locally (at state level), the economic impacts from these transmission investments extend beyond state boundaries so that the planning and approval process for such investment falls under FERC jurisdiction. As a result of such jurisdictional conflict adequate side payments among market participants are not always physically or politically feasible (for instance, this would be the case of a network expansion that benefit a particular generator or load in another state, so that the cost of the expansion is not paid for by those who truly benefit from it).¹ Consequently, the maximization of social welfare may not translate to Pareto efficiency and other optimizing objectives should be considered. Unfortunately, alternative objectives may produce conflicting results with regard to the desirability of transmission investments. Thus, certain socially beneficial projects may still result in winners and losers while projects with willing-to-fund investors may nevertheless be socially inefficient. Under these conditions, for an assessment methodology to be effective, it must be capable of evaluating the economic impacts on the various effected stakeholders and account for strategic responses that could enhance or impede the enhancement's objectives.

One potential solution to the aforementioned jurisdictional conflict is the so-called "participant funding", which was proposed by FERC in its 2002 Notice of Proposed Rulemaking (NOPR) on Standard Market Design (FERC 2002, 98-115). Roughly,

¹ For example, it is really hard to convince people in Idaho that they should pay for a transmission line connecting Idaho and California to carry their cheap power to Californians. On the contrary, they would probably be worry about both a likely increase in their electricity prices and a potential reduction in the reliability of their own system because of the increased risk of cascading failures (due to the expansion).

participant funding is a mechanism whereby one or more parties seeking the expansion of a transmission network (who will economically benefit from its use) assume funding responsibility. This scheme would assign the cost of a network expansion to the beneficiaries from the expansion thus, eliminating (or, at least, mitigating) the side-payments' problem mentioned above. This policy is based on the rationale that, although most network expansions are used by and benefit all users, some few network expansions will only benefit an identifiable customer or group of customers (such as a generator building to export power or a load building to reduce congestion).

Although participant funding would potentially encourage greater regional cooperation to get needed facilities sited and built, this approach has some caveats in practice. The main shortcomings of participant funding are:

- The benefits from network upgrades are difficult to quantify and to allocate among market participants (and, thus, it could be difficult to identify and avoid detrimental expansions that benefit some participants, either at the expense of others or decreasing social welfare).
- Mitigation of network bottlenecks is likely to require a program of system-wide upgrades, from which almost all market participants are likely to benefit, but for which the cumulative benefits can be difficult to capture through participant funding.
- After some period of time (but less than the economic life of the upgrade), if the benefits begin to accrue to a broader group of customers, then some form of crediting mechanism should be established to reimburse the original funding participants. However, this would basically be a reallocation of sunk costs.
- Participant funding could lead to a sort of “incremental expansions” over time. Because transmission investments tend to be lumpy, these incremental expansions may be inefficient in the long run and more costly to consumers.
- Providing some form of physical (capacity-reservation) rights in exchange for participant-funded investments could allow the exercise of market power by the withholding of the new capacity and, thereby, create new transmission bottlenecks.
- An extensive reliance on participant funding and incentive rates for transmission could lead to accelerated depreciation lives for ratemaking purposes, which will increase the risk profile for this portion of the industry.

Most of the works found in the literature about transmission planning in deregulated electric systems consider single-objective optimization problems (maximization-of-social-welfare in most of the cases) while literature that considers multiple optimizing objectives is scarce. London Economics International LLC² developed a methodology to evaluate specific transmission proposals using an objective function for transmission appraisal that allows the user to vary the weights applied to producer and consumer surpluses. However, London Economics' study has no view on what might constitute appropriate weights nor on how changes in the weights affect the proposed methodology.

² London Economics International LLC. 2002. *Final Methodology: proposed approach for evaluation of transmission investment*. Report prepared for the CAISO by London Economics International LLC. Cambridge, MA.

Furthermore, economic assessments of transmission investments are typically based on locational marginal pricing (LMP), given the current and planned generation stock . These assessments typically ignore market power effects and potential strategic response by generation investments to the transmission upgrades. For example, the Transmission Economic Assessment Methodology (TEAM) developed by the California ISO³ is based on the “gains from trade” principle⁴, which ignores possible distortion due to market power⁵.

This project focused on the exploration of a tiered approach for determining the economic effects of a transmission project in terms of social welfare, market power mitigation and individual player impacts. The first tier provides a reference signal of the worth of the project without accounting for changes in market players’ behavior. The second tier explicitly incorporates the modifications in the behavior of various market players in response to the implementation of a transmission project. The third tier, in addition, incorporates possible impacts in the asset investment decisions of the market players. This three-tier approach provides a comprehensive and integrated framework to evaluate the worth of transmission projects.

Benefits

The methodology introduced in this project provides a highly useful and practical approach to improve the way in which the economic consequences and worth of a transmission enhancement project are evaluated by ISO/RTOs, regulators, investors and impacted market players. The approach developed in this project addresses the needs for an assessment methodology that appropriately account for the economic impacts of a transmission project from a diverse set of perspectives and incorporate the response strategies in terms of generation investment to a transmission project. Transmission investments have failed to keep up with the increases in the demand and the markedly changed utilization of the grid under competitive conditions. Therefore, the availability of the proposed approach may provide the tool to change the stagnation in the current situation in transmission investment. ISO/RTOs that are responsible for regional planning and the assessment of transmission projects as well as transmission investment firms involved in initiating and funding such projects will particularly benefit from this proposed work. Moreover, all transmission customers will be able to assess the impacts of transmission modifications.

Technical Approach

The basic approach in this project is based on a three-tier framework of models with the increasing level of detail in the representation of the interaction of the grid and markets. While all the models serve in the assessment of the economic impacts of a transmission

³ California ISO. (2004). Transmission Economic Assessment Methodology (TEAM). Available at www.caiso.com/docs/2003/03/18/2003031815303519270.html

⁴ Sheffrin, A. (2005). Gains from trade and benefits of transmission expansion for the IEEE Power Engineering Society. *Proceedings of the IEEE Power Engineering Society 2005 general meeting*. San Francisco, USA: Track 5.

⁵ While TEAM considers alternative generation-expansion scenarios with and without the transmission upgrades, as far as we know, this generation-expansion analysis is “open-loop” in the sense that TEAM does not take into account the potential strategic response to transmission investment from generation firms who may alter their investment plans in new generation capacity. Unlike the assumptions made in our model, two key assumptions regarding generation investment underlying TEAM are: (i) investment in new generation capacity is non-strategic and independent of transmission planning and (ii) new investment in generation capacity is just sufficient to maintain prices at levels that are competitive while providing an adequate rate of return.

enhancement project, they vary in terms of the specific assumptions regarding the interactions between the behavior of generators in markets and the modified grid, as well as a change in investment in generation assets as a consequence of the grid enhancement.

The initial task in the project was the construction a general reference framework for thinking about the transmission investment problem. The first tier of the framework involves the development of a procedure to assess the impacts of a modification of the grid under the assumption that there is no change in the behavior of the sellers and buyers in the electricity markets. The procedure provides the appropriate calculation of social welfare changes and reductions in the loss of economic efficiency due to the transmission enhancement. In this task, we have illustrated how the objectives of market efficiency increase and social welfare maximization may compete with those of the individual players and the investor. Each market player may be differently affected, faring better or worse as a result of the new investment. For example increasing transmission capacity between a low cost generation node and a high cost load pocket will increase exports from the low cost node. While such a project may enhance social welfare it is likely to reduce cost to consumers in the load pocket but, at the same time increase the cost of electricity to consumers at the generation node. In addition, in the presence of longer-term bilateral transactions, changes in the grid may change the nature or the number of constraints whenever a new facility is added. The nature of these changes in the constraints and the impacts on individual players and society for various levels of enhancements and locations will be investigated. The results serve to determine a basis, with respect to which, the results of the more detailed models will be compared.

The second task concerned the development of the more detailed second tier in which we explicitly represent the changes in bidding behavior in response to the modified network constraints. In the proposed formulation, the market prices and production quantities are obtained from a Nash-Cournot game that characterizes the market equilibrium and those results from profit maximizing offers by the generation firms and the optimal redispatch by the system operator. This second tier modeling determines, therefore, the social welfare and competitiveness implications as well as the impacts on various players due to a transmission project. Note that we maintain the set of generation assets unchanged.

The third task focused on the construction of the third tier modeling in which we also represent the formulation of changes in generation investment decisions induced by the transmission enhancement project. For this purpose, we will construct a two-stage subgame perfect Nash equilibrium model in which the selling entities interact through two time periods. The sellers make generation investment decisions in the first period with the anticipation of the equilibrium in the second period, when the market quantities and prices are set with the modifications in the grind *and* the generation assets. This equilibrium determines the market prices and quantities as a result of profit maximization by the selling entities and optimal redispatch by the system operator.

For computational tractability we introduced certain simplifying assumptions. While there is no restriction on the network topology since the modeling is general and can accommodate any particular network structure, we assume that each node is both a

demand and a generation node. Moreover, we assume that all generation capacity at each node is owned by a single firm. We allow each generation firm to exercise local market power and we characterize the market through Cournot competition. Furthermore, the modeling allows the representation of multiple congested lines and considers explicitly contingencies for describing demand shocks, generation outages and transmission line outages.

We can view the proposed model in the context of a three-period sequential decision framework, as depicted below. We assume that, in each period, each player makes its decisions based on the activities and outcomes in all preceding periods and forms rational expectations for the outcomes of the current and subsequent periods. A distinguishing characteristic of the proposed three-tier modeling is the extent to which this rational expectation is considered together with the weighting given to the current bidding behavior. In period 3, the market clearing takes place with the equilibrium quantities and prices of electricity computed for the system incorporating the modifications in the transmission grid and generation assets as specified in the periods 1 and 2.

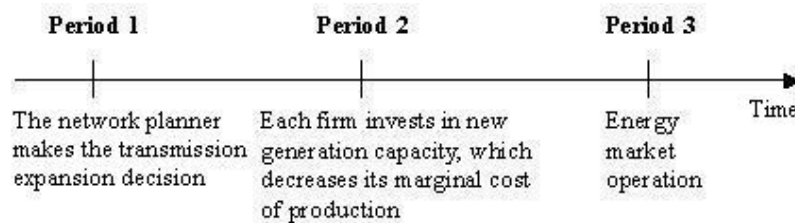

We represent the physical grid with the DC power flow approximation in modeling the energy market equilibrium. Specifically, flows on lines are evaluated using the power transfer distribution factors (PTDFs). We represent uncertainty through the deployment of the PTDF matrices corresponding to each contingency-impacted network topology. We assume that the probabilities of all such credible contingencies are public knowledge. We also assume that generation and transmission capacities as well as demand shocks are subject to random fluctuations whose impacts are represented in period 3 and incorporated in the determination of the market outcome decisions by the system operator.

In period 2, we can rely either on the existing generation base case scenario or endogenize the generation expansion decision in response to the transmission project modification. In modeling the generation investment decision we assume that each generation firm invests in new generation capacity in order to lower its marginal costs of production at every output level. The return from the generation capacity investment decisions made in period 2 occurs in period 3, when such investments enable the firms to produce electricity at lower costs and sell more of it profitably. Thus in making their investment decisions in period 2 each generation entity is aware of the transmission enhancement made in period 1 and forms rational expectations regarding the investments made by their competitors and the resulting market equilibrium in period 3. We model the generation investment and production decisions of the competing generation firms as a two-stage subgame perfect Nash equilibrium. The system operator transmission enhancement decision in period 1 is modeled as a Stackelberg leader in this game. The

operator evaluates various transmission upgrade projects with the anticipation of the generators' response in periods 2 and 3. The optimization of the transmission investment decision will therefore determine the optimal way of inducing generation investment so as to maximize the social welfare.

The above three stage model is used to formally define alternative transmission expansion planning processes whose objective is to maximize social welfare, under different levels of central control and foresight regarding strategic interactions. In particular we consider as a benchmark, an idealized planning process under a fully vertically integrated social planner (FVISP) who co-optimizes transmission and generation investment and subsequently operate the generation system so as to maximize social welfare. As a second benchmark we consider a fictional integrated resource planner (IRP) in an environment where generators are privately owned and operated so as to maximize owners profits. The IRP co-optimizes transmission and generation investment with perfect foresight of the strategic interaction among generators in the energy market. We use these benchmarks to highlight the benefits of a forward looking transmission planning paradigm which we attribute to a proactive system operator (PSO) who plans transmission expansion while anticipating the strategic responses of privately owned generation firms which interact with each both in deciding how and where to expand their generation resources and in the subsequent energy market. The PSO outcome is contrasted (and shown to be inferior) to those of a reactive system operator (RSO), representing the prevailing transmission planning in restructured US markets. The RSO plans transmission in response to current and planned generation investments while ignoring the possible impact of the transmission expansion on generation investment and subsequent energy markets. We demonstrate analytically and by means of a case analysis that the RSO plan may be suboptimal and may result in lower social welfare than the PSO plan whereas the PSO plan can capture much of the theoretical benefits of an idealized (but impractical) IRP approach.

In the following we provide more details regarding each of the tasks outlined above and the analysis of the various aspects concerning economic assessment of transmission investment

2. Development of a General Analytic Framework for the Transmission Network Investment Problem

The objective of this task was to construct a general analytic framework for the transmission network investment problem and to demonstrate its application to some test systems. The work made use of the multi-layer structure developed for the analysis of transmission planning and investment in the unbundled, open access environment. The framework correctly captures the salient characteristics including the decentralized decision making and the separation of the control and operation of the grid from its ownership. We introduce appropriate metrics that are useful to the central entity responsible for transmission planning and provide meaningful measures of the effects of a modification in the grid over the planning horizon.

2.1 Conceptual framework

One critically important outcome of the restructuring is the more frequent stressing of the transmission grid due to the creation of congestion situations. Congestion impacts market players in many different ways. Congestion may prevent the use of lower-priced generators to meet the load and consequently may result in a generation/demand schedule with higher total costs and losses of market efficiency. Also, congestion facilitates the opportunities to exercise market power through gaming by some players to increase their profits. The metrics in our framework meaningfully measure the congestion impacts in power/energy and monetary terms. In the planning of new transmission asset additions, the reduction of congestion plays a key role. But, the objectives of market efficiency increase and social welfare maximization compete with those of the individual market players and of the investors. A key complication is that each market participant may be differently affected, faring better or worse as a result of congestion relief under the new investments.

Our starting point was the three-layer framework developed earlier. We extended that construct by adding an investment layer for the analysis of expansion problems and constructing the appropriate interconnections with the three layers. The extended framework consists of four interconnected layers — the physical network, the commodity market, the financial market and the investment — and the associated information flows to describe the interactions between these layers. The physical network layer is used to represent the transmission physical flows in the network. The relationships between the line flows and the nodal injections and the consideration of various network constraints allow the characterization of congestion conditions. The commodity market layer represents the behavior of the pool market players in terms of their bids and offers, the requests for transmission by the bilateral transactions including their willingness to pay and the *IGO* decision making process. The models of the *FTR* and the *FTR* markets constitute the financial market layer. The new layer addition as the fourth layer provides the capability to analyze transmission investment issues. We use this capability to determine which transmission investment assets are possible candidates and when they will be added to the system. In this way, we can address the dual objectives of selecting the optimal transmission investment decisions and determining the optimal combination

of the selected assets over a time horizon spanning the planning horizon. We integrated this new layer by introducing the appropriate additional information flows to represent the interactions between the four layers. These information flows are shown in Fig. 1.

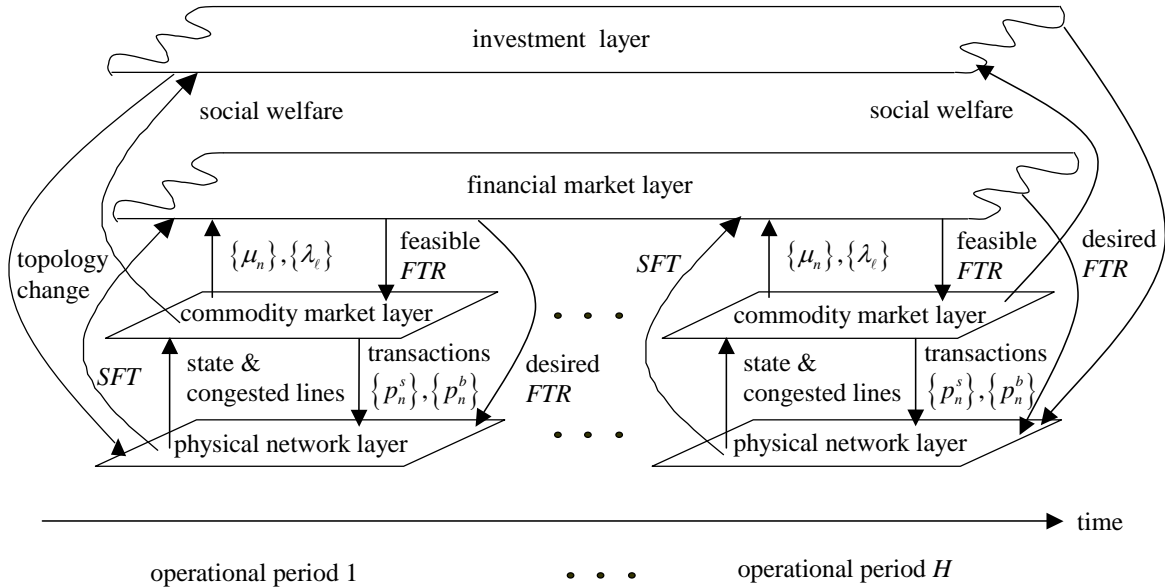

Figure 1: The four-layer framework structure

We introduce appropriate metrics that measure the improvement of a new transmission asset investment evaluated from the central planning entity point of view. The metrics to evaluate investments in transmission assets are the *social welfare*, the *loss of efficiency* and the *congestion rents*. In addition, for the sake of completeness we evaluate both the *producer surplus* and the *consumer surplus* metrics. The social welfare metric measures the overall impact of both sellers and buyers and explicitly represents the impact of bilateral transactions. The market efficiency loss metric is the reduction in the social welfare caused by congestion and quantifies the value of the energy that is neither sold nor bought due to the presence of congestion in the system. The loss of market efficiency is known in the economic literature as the dead-weight loss.

The consistency of the measured values in terms of these metrics allows the comparison of disparate transmission investment projects and their effective prioritization. A key element of the framework is the deployment of an optimization scheme to maximize the social welfare with and without the transmission asset investments under various bidding behaviors of the market players and contracting conditions. The framework lends itself nicely to scenario analysis and provides a consistent basis to compare the impacts of various sources of uncertainty, such as load growth, bidding behavior, resource availability and fuel prices, over the planning horizon.

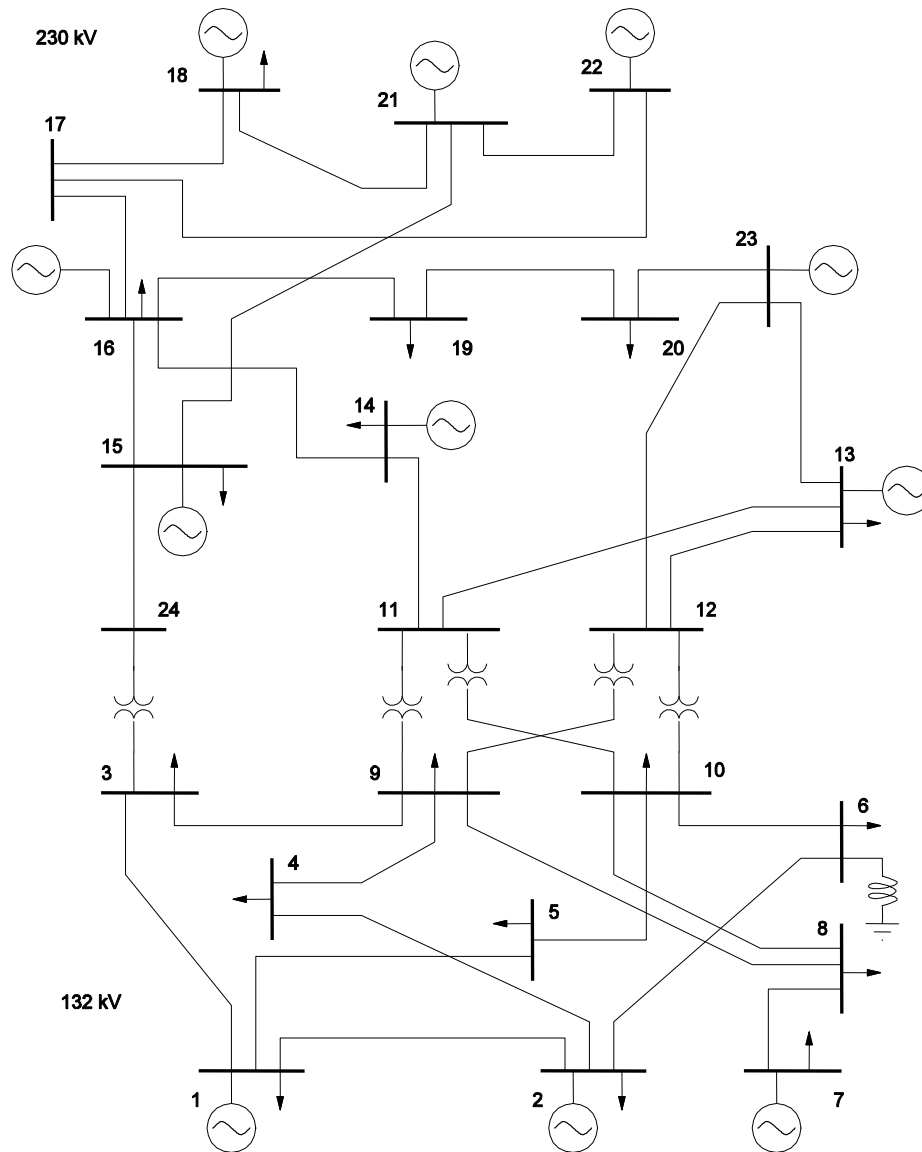

Figure 2: The IEEE 24-bus reliability test system topology

We investigated the capabilities of the analytical framework using the IEEE 24-bus reliability test system (RTS). This system, illustrated in Fig. 2, provides a good test bed for assessing the many issues involved in the assessment of different enhancements to a network. We investigated several transmission expansion scenarios on the IEEE 24-bus RTS network under various bidding conditions and bilateral contracts for a set of selected line investments. The results using both pool-based markets and combined pool-bilateral contract markets provide a good illustration of the capability of the framework to effectively address realistic questions in transmission investment. We considered a comprehensive set of scenarios for various seasonal load patterns and with different bidding behavior and assessed the results to gain insights into the impacts of different investment alternatives. In addition, we also investigated values of the metrics for all

possible combinations of new lines in the various scenarios. The analysis allowed us to draw a number of important conclusions from our case studies.

The development of the generalized framework is a key accomplishment of the Project since the framework is comprehensive as it represents all the relevant aspects of the transmission asset investment problem under competitive markets. A salient characteristic is the ability to compare, on a consistent basis, disparate transmission investment alternatives. Indeed, the framework constitutes a powerful policy analysis tool. With the metrics introduced to evaluate the impacts of a transmission asset investment, we assessed the capability of the framework on various scenarios. have introduced appropriate. The illustrative case studies presented provide good insights into the ramifications of investment in transmission in the competitive environment.

2.2 Documentation

The framework described in this section has been the subject of a number of invited presentations, including the two cited below. Efforts are underway to produce a paper for archival publication.

G. Gross, "Transmission Investment In The Competitive Environment," invited seminar at the University of Texas at Arlington, Texas, January 26, 2007.

G. Gross, "Transmission Expansion In Competitive Electricity Markets," invited seminar at the University of Pavia, Italy, May 23, 2008.

3. Distributional Implications and Alternative Valuation Criteria for Transmission Investments

In general, transmission investment effects rent transfers from load pocket generators and generation pocket consumers to load pocket consumers and generation pocket generators. However, load pocket consumers and generation pocket generators cannot simply decide to build a line linking them. Their decision will be subject to scrutiny by not only an ISO, but also state and federal energy and environmental regulators. In this type of environment, the “losers” from transmission investment could be expected to expend up to the amount of rents that they stand to lose to block the transmission investment. This rent dissipation is wasteful. Moreover, it may block socially beneficial projects from being built. Nevertheless, it is important to mention that the usual coordination problem faced by the beneficiaries of a transmission expansion also applies to the losers from the expansion. The following examples illustrate the distributional impacts of transmission investments and the potential incentives that some market participants could have to exercise political power in order to block a social-welfare-improving transmission expansion project.

3.1 Diverse distributional impact of transmission investment

Consider a network composed of two cities satisfying their electricity demand with local generation firms. For simplicity, assume there exists only one (monopolist) generation firm in each city, which have unlimited generation capacity. We assume that the marginal cost of supply at city 1 is lower than that at city 2. In particular, suppose the marginal costs of generation are constant⁶ and equal to zero at city 1 and \$20/MWh at city 2. Assume the inverse demand functions are linear, given by $P_1(q) = 100 - 0.1 \cdot q$ at city 1 and by $P_2(q) = 120 - 0.2 \cdot q$ at city 2, in \$/MWh.

Under the monopolistic (self-sufficient-cities) scenario, the city 1 firm optimally produces $q_1^{(M)} = 500$ MWh (on an hourly basis) and charges a price $P_1^{(M)} = \$50/\text{MWh}$ while the city 2 firm optimally produces $q_2^{(M)} = 250$ MWh and charges a price $P_2^{(M)} = \$70/\text{MWh}$. With these market-clearing quantities and prices, the firms' profits are $\Pi_1^{(M)} = \$25,000/\text{h}$ and $\Pi_2^{(M)} = \$12,500/\text{h}$, respectively. The consumer surpluses are $CS_1^{(M)} = \$12,500/\text{h}$ for city 1 consumers and $CS_2^{(M)} = \$6,250/\text{h}$ for city 2 consumers.⁷

Now, consider the scenario in which there is unlimited transmission capacity between the two cities. This situation corresponds to a duopoly facing an aggregated demand given by (in \$/MWh):

$$P(Q) = \begin{cases} 120 - 0.2 \cdot Q & , \text{if } Q < 100 \\ 106.66 - 0.066 \cdot Q & , \text{if } Q \geq 100 \end{cases} , \text{ where } Q = q_1 + q_2.$$

⁶ The assumption that marginal costs of supply are constant is not critical, but it simplifies calculations.

⁷ Under monopoly, a firm optimally chooses a quantity such that the marginal cost of supply equals its marginal revenue. If the marginal cost of production is constant and equal to c and the demand is linear, given by $P(q) = a - b \cdot q$, where $a > c$, then the monopolist will optimally produce $q^{(M)} = (a-c)/(2b)$ and charge a price $P^{(M)} = (a+c)/2$, making a profit of $\Pi^{(M)} = (a-c)^2/(4b)$. Under these assumptions, the consumer surplus is equal to $CS^{(M)} = (a-c)^2/(8b)$.

We assume that generation firms behave as Cournot oligopolists in this case. Under this scenario, the firm at city 1 optimally produces $q_1^{(D)} = 633$ MWh (on an hourly basis) while the firm at city 2 optimally produces $q_2^{(D)} = 333$ MWh. The price charged by both firms is equal to $P^{(D)} = \$42.2/\text{MWh}$. With these new market-clearing quantities and price, the firms' profits are $\Pi_1^{(D)} = \$26,741/\text{h}$ and $\Pi_2^{(D)} = \$7,407/\text{h}$, respectively.⁸ Furthermore, the consumer surpluses are $CS_1^{(D)} = \$16,691/\text{h}$ for the city 1 consumers and $CS_2^{(D)} = \$15,124/\text{h}$ for the city 2 consumers.

In this example, by linking both cities with a high-capacity transmission line, we replace some expensive power produced at city 2 by cheaper power generated at city 1, which makes city 2 consumers clearly better off. Unfortunately, this is not the only implication of the construction of such a transmission line. The city 2 firm reduces its profit because its retail price decreases as result of the competition between generation firms introduced by the new transmission line.

Indeed, the numerical results reveals that the construction of the transmission line has the following consequences: the city 1-consumers' surplus increases from $\$12,500/\text{h}$ to $\$16,691/\text{h}$, the city 2-consumers' surplus increases from $\$6,250/\text{h}$ to $\$15,124/\text{h}$, the city 1-firm's profit increases from $\$25,000/\text{h}$ to $\$26,741/\text{h}$, and the city 2-firm's profit decreases from $\$12,500/\text{h}$ to $\$7,407/\text{h}$. From these results, it is clear that the city 2 firm (load pocket generator) will oppose the construction of the line linking both cities because this line will decrease its profit, transferring its rents to the other market participants. Consequently, depending on the relative political power of the city 2 firm, this network-expansion project could be blocked, even though it could be socially beneficial (depending on the transmission investment costs)⁹.

The problem of rent transfer may arise even in the absence of market power. To illustrate this fact, assume that city 1 (generation pocket) has 1,000 MW of local generation capacity at $\$10/\text{MWh}$ marginal cost and another 500 MW of generation capacity at $\$20/\text{MWh}$ marginal cost, with 600 MW of local demand, while city 2 has 800 MW of generation capacity at $\$30/\text{MWh}$ marginal cost and local demand of 1,000 MW. Furthermore, assume that all generation power is offered at marginal cost and that a 300 MW transmission line connects the two cities. Under this scenario, the market clearing prices are $\$10/\text{MWh}$ in city 1 and $\$30/\text{MWh}$ in city 2 and 300 MW are exported from city 1 to city 2. A 300 MW increase in transmission capacity would allow replacement of 300 MW of load served at $\$30/\text{MWh}$ by imports from city 1, of which 100 MW can be produced at $\$10/\text{MWh}$ and another 200 MW can be produced at $\$20/\text{MWh}$. The social benefit from such an expansion is, therefore, $\$4,000/\text{h}$. Assuming that the amortized upgrade costs is below $\$4,000/\text{h}$, the upgrade is socially beneficial. The market consequences of such an upgrade are that the market clearing price at city 1 increases

⁸ Under duopoly, the Cournot firms simultaneously choose quantities such that their marginal cost of supply equals their marginal revenue, but assuming the quantity produced by the other firm is fixed. If the marginal costs of production are constant for both firms, given by c_1 and c_2 respectively, and the aggregate inverse demand is linear, given by $P(Q) = A - B \cdot Q$, where $A > c_1$ and $A > c_2$, then firm i will optimally produce $q_i^{(D)} = (A - 2c_i + c_j) / (3B)$, with $j \neq i$ and $i \in \{1,2\}$. Under these assumptions, the duopolistic price will be $P^{(D)} = (A + c_1 + c_2) / 3$ and firm i will make a profit of $\Pi_i^{(D)} = (A - 2c_i + c_j)^2 / (9B)$, with $j \neq i$ and $i \in \{1,2\}$.

⁹ Note that, in general, building transmission to eliminate all congestion is not necessarily optimal (especially when construction cost is accounted for), but it can be superior to the case of no connectivity. In our example, we do not advocate elimination of congestion, but use these two polar extremes for illustrative purposes.

from \$10/MWh to \$20/MWh while the market clearing price at city 2 stays \$30/MWh as before, with 600 MW being exported from city 1 to city 2. Thus, consumers and generators in city 2 are neutral to the expansion, consumer surplus in city 1 will drop by \$6,000/h, generator's profits in city 1 will increase by \$10,000/h, and the merchandising surplus of the system operator will remain unchanged (the ISO merchandising surplus on the pre-expansion imports drops \$3,000/h, but it picks up \$3,000/h for the incremental imports). Clearly, such an expansion is likely to face stiff opposition from consumers in city 1, but it would be strongly favored by the generators at city 1, who would be more than happy to pay for it (as long as the amortized investment cost does not exceed \$10,000/h). In fact, generators at node 1 would favor such an investment even if its amortized cost exceed the \$4,000/h benefits, which would make such an investment socially inefficient to the detriment of city 1 consumers.

By contrast to the above example, a small incremental upgrade of 90 MW in the transmission capacity would be socially beneficial increasing social surplus by \$1,800/h without affecting the market clearing prices in either city. In such a case, neither the generators nor the consumers on either side will benefit (or be harmed) by the expansion and, thus, the entire gain will go to the ISO in the form of merchandising surplus. In such a case, a merchant transmission owner could be induced to undertake the transmission upgrade in exchange for financial transmission rights (FTRs) that would entitle her to the locational marginal price differences for the incremental capacity, thus allowing the investor to capture the entire social surplus gain due to the expansion. The use of FTR allocation to align the incentives of market participants and investors will be further discussed in Section 4.

3.2 Conflicting planning objectives

We shall use a simple two-node network example, as shown in Figure 3, which is sufficient to highlight the potential incompatibilities among the planning objectives and their policy implications. This example is chosen for simplicity reasons and does not necessarily represent the behavior of a real system.

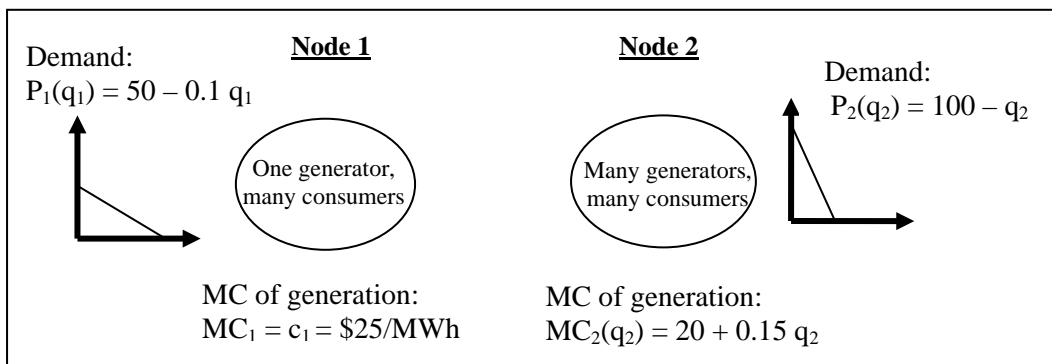

Figure 3: An illustrative two-node example

As a general framework of the example presented here, we assume that the transmission system uses nodal pricing, transmission losses are negligible, consumer surplus is the correct measure of consumer welfare (e.g., consumers have quasi-linear utility), generators cannot purchase transmission rights (and, thus, their bidding strategy is independent of the congestion rent), and the Lerner index (defined as the fractional price markup, i.e. $[\text{price} - \text{marginal cost}] / \text{price}$) is the proper measure of local market power.

Consider a network composed of two unconnected nodes where electricity demand is served by local generators. Assume node 1 is served by a monopoly producer while node 2 is served by a competitive fringe.¹⁰ For simplicity, suppose that the generation capacity at each node is unlimited. We also assume both that the marginal cost of generation at node 1 is constant (this is not a critical assumption, but it simplifies the calculations) and equal to $c_1 = \$25/\text{MWh}$, and that the marginal cost of generation at node 2 is linear in quantity and given by $\text{MC}_2(q_2) = 20 + 0.15 \cdot q_2$. Moreover, we assume linear demand functions. In particular, the demand for electricity at node 1 is given by $P_1(q_1) = 50 - 0.1 \cdot q_1$ while the demand for electricity at node 2 is given by $P_2(q_2) = 100 - q_2$.

We analyze the optimal expansion of the described network under each of the following optimizing objectives: (1) maximization of social welfare, (2) minimization of local market power, (3) maximization of consumer surplus, and (4) maximization of producer surplus.¹¹ We limit the analysis to only two possible network expansion options: i) doing nothing (that is, keeping each node as self-sufficient) and ii) building a transmission line with “adequate” capacity (that is, building a line with high-enough capacity so that the probability of congestion is very small). For the particular cases we present here, we can easily verify that the optimal expansion under each of the four considered optimizing objectives is truly either doing nothing or building a transmission line with adequate capacity. In the general case, we can justify this simplification based on the lumpiness of transmission investments.

Under the scenario in which each node satisfies its demand for electricity with local generators (self-sufficient-node scenario), the generation firm located at node 1 behaves as a monopolist (that is, it chooses a quantity such that its marginal cost of supply equals its marginal revenue) while the generation firms located at node 2 behave as competitive firms (that is, they take the electricity price as given by the market-clearing rule: demand equals marginal cost of supply).

Accordingly, under the self-sufficient-node scenario (SSNS), the generation firm at node 1 optimally produces $q_1^{(\text{SSNS})} = 125 \text{ MWh}$ and charges $P_1^{(\text{SSNS})} = \$37.5 / \text{MWh}$. With this electricity quantity and price, the producer surplus at node 1 (which, in this example, is equivalent to the monopolist’s profit) is $\text{PS}_1^{(\text{SSNS})} = \$1,563 / \text{h}$ and the consumer surplus at

¹⁰ The fact that the generation firm located at node 1 can exercise local market power is a crucial assumption for the purpose of this example. Without considering local market power, the results we show in this section are no longer valid. However, this supposition is fairly realistic. In fact, perfectly competitive markets are not very common in the power generation business. In our example, the perfect-competition assumption at node 2 is only made for simplicity and it can be eliminated without changing any of the qualitative results presented in this section.

¹¹ In this section, we show that, for given demand functions, the optimal expansions under the four considered optimizing objectives vary depending on the cost structures of generators. To do this, we analyze the optimal expansion of the two-node network when changing the marginal cost of generation at node 1 (i.e., when we change c_1) while keeping unaltered the cost structure of the generators at node 2.

this node equals $CS_1^{(SSNS)} = \$781/\text{h}$. The Lerner index at node 1 is $L_1^{(SSNS)} = 0.33$.¹² On the other hand, under the SSNS, the generation firms located at node 2 optimally produce an aggregate amount equal to $q_2^{(SSNS)} = 69.6$ MWh, and the market-clearing price is $P_2^{(SSNS)} = \$30.4/\text{MWh}$. With this electricity quantity and price, the producer surplus at node 2 is $PS_2^{(SSNS)} = \$363/\text{h}$ and the consumer surplus at this node is $CS_2^{(SSNS)} = \$2,420/\text{h}$.¹³ From the previous results, we can compute the total producer surplus, the total consumer surplus, and the social welfare under the SSNS. The numerical results are given by: $PS^{(SSNS)} = PS_1^{(SSNS)} + PS_2^{(SSNS)} = \$1,926/\text{h}$; $CS^{(SSNS)} = CS_1^{(SSNS)} + CS_2^{(SSNS)} = \$3,201/\text{h}$; and $W^{(SSNS)} = PS^{(SSNS)} + CS^{(SSNS)} = \$5,127/\text{h}$; respectively.

Now, we consider the scenario in which there is adequate (ideally unlimited) transmission capacity between the two nodes (nonbinding-transmission-capacity scenario). Under this scenario, the generation firms face an aggregate demand given by:

$$P(Tq) = \begin{cases} 100 - Tq & , \text{if } Tq < 50 \\ 54.5 - 0.09 \cdot Tq & , \text{if } Tq \geq 50 \end{cases} ,$$

where Tq is the total quantity of electricity produced. That is, $Tq = q_1 + q_2$, where q_1 is the amount of electricity produced by the firm located at node 1 and q_2 is the aggregate amount of electricity produced by the firms located at node 2.

Under the nonbinding-transmission-capacity scenario (NBTCS), the two nodes may be treated as a single market where the generator at node 1 and the competitive fringe at node 2 jointly serve the aggregate demand of both nodes at a single market clearing price. We assume that the monopolist at node 1 behaves as a Cournot oligopolist interacting with the competitive fringe. That is, under the NBTCS, we assume both that the monopolist at node 1 chooses a quantity such that its marginal cost of supply equals its marginal revenue, taking the output levels of the other generation firms as fixed, and that the generation firms at node 2 still take the electricity price as given by the market-clearing rule.

Thus, according to the Cournot assumption, under the NBTCS, the monopolist at node 1 optimally produces $q_1^{(NBTCS)} = 112$ MWh while the competitive fringe at node 2 optimally produces $q_2^{(NBTCS)} = 101.2$ MWh (these output levels imply that there is a net transmission flow of 36 MWh from node 2 to node 1). In this case, the market-clearing price (which is the price charged by all firms to consumers) is $P^{(NBTCS)} = \$35.2/\text{MWh}$. With these new electricity quantities and prices, the producer surplus at node 1 is equal to $PS_1^{(NBTCS)} = \$1,139/\text{h}$ and the producer surplus at node 2 is equal to $PS_2^{(NBTCS)} =$

¹² Under monopoly, if the marginal cost of production is constant and equal to c and the demand is linear, given by $P(q) = a - b \cdot q$, where $a > c$, then the monopolist will optimally produce $q^{(M)} = (a - c) / (2b)$ and charge a price $P^{(M)} = (a + c) / 2$, making a profit of $\Pi^{(M)} = (a - c)^2 / (4b)$. Under these assumptions, the consumer surplus is equal to $CS^{(M)} = (a - c)^2 / (8b)$, and the Lerner index at the monopolist's node is equal to $L^{(M)} = (P^{(M)} - c) / P^{(M)} = (a - c) / (a + c)$.

¹³ Under perfect competition, if the marginal cost of supply is linear, given by $MC(q) = c + d \cdot q$, and the inverse demand function is given by $P(q) = a - b \cdot q$, where $a > c$, then the market will optimally produce a quantity $q^{(PC)} = (a - c) / (b + d)$ and the market-clearing price will be $P^{(PC)} = (a \cdot d + b \cdot c) / (b + d)$. Under these assumptions, the producer surplus is equal to $PS^{(PC)} = (d \cdot (a - c)^2) / (2 \cdot (b + d)^2)$ and the consumer surplus is $CS^{(PC)} = (b \cdot (a - c)^2) / (2 \cdot (b + d)^2)$.

\$768/h.¹⁴ As well, the consumer surpluses are $CS_1^{(NBTCs)} = \$1,099/h$ for node 1's consumers and $CS_2^{(NBTCs)} = \$2,101/h$ for node 2's consumers. The new Lerner index at node 1 is $L_1^{(NBTCs)} = 0.29$.

From the above results, we can compute the total producer surplus, the total consumer surplus, and the social welfare under the NBTCs. However, these calculations require knowing who is responsible for the transmission investment costs. Without loss of generality, we assume that an independent entity (other than the existing generation firms and consumers) incurs in the transmission investment costs. Consequently, under the NBTCs, total producer surplus (not accounting for transmission investment cost) is $PS^{(NBTCs)} = PS_1^{(NBTCs)} + PS_2^{(NBTCs)} = \$1,907/h$; total consumer surplus is $CS^{(NBTCs)} = CS_1^{(NBTCs)} + CS_2^{(NBTCs)} = \$3,200/h$; and social welfare is $W^{(NBTCs)} = PS^{(NBTCs)} + CS^{(NBTCs)} - \text{investment costs} = \$5,107/h - \text{investment costs}$.

Comparing both the SSNS and the NBTCs, we can observe that the expansion that minimizes local market power is building a transmission line with "adequate" capacity (at least theoretically, with capacity greater than 36 MWh) since $L^{(NBTCs)} < L^{(SSNS)}$. However, the expansion that maximizes social welfare would keep each node as self-sufficient ($W^{(NBTCs)} < W^{(SSNS)}$, even if the investment costs were negligible). Moreover, both the expansion that maximizes total consumer surplus and the expansion that maximizes total producer surplus are keeping each node as self-sufficient (i.e., $CS^{(NBTCs)} < CS^{(SSNS)}$ and $PS^{(NBTCs)} < PS^{(SSNS)}$). This means that, in this particular case, while the construction of a non-binding-capacity transmission line linking both nodes minimizes the local market power of generation firms, this network expansion decreases social welfare, total consumer surplus, and total producer surplus.

Figure 4 demonstrates that, in this particular case, the construction of the non-binding-capacity transmission line reduces social welfare even if the investment costs were negligible. Furthermore, this figure leads to an interesting observation: if the consumers at node 1 (and/or the producers at node 2) had enough political power, then they could encourage the construction of a non-binding-capacity transmission line linking both nodes even though it would decrease social welfare. That is, in this case, the "winners" from the transmission investment (consumers at node 1 and generation firms at node 2) can be expected to expend up to the amount of rents that they stand to win to obtain approval of this expansion project although it reduces social welfare.

¹⁴ Under the NBTCs, assuming generators behave as Cournot firms, if the marginal costs of supply at nodes 1 and 2 are $MC_1(q_1) = c_1$ and $MC_2(q_2) = c_2 + d_2 \cdot q_2$ respectively, and the aggregate demand is linear, given by $P(Tq) = A - B \cdot Tq$, where $A > c_1$ and $A > c_2$, then the optimal output levels solve the following two equations:

$$\begin{aligned} A - 2 \cdot B \cdot q_1 - B \cdot q_2 &= c_1 & (\text{or } MR_1 = MC_1) \text{ and} \\ A - B \cdot (q_1 + q_2) &= c_2 + d_2 \cdot q_2 & (\text{or } P^{(NBTCs)} = MC_2) \end{aligned}$$

The solution to this system of equations is: $q_1^{(NBTCs)} = (B \cdot (c_2 - c_1) + d_2 \cdot (A - c_1)) / (B \cdot (B + 2 \cdot d_2))$ and $q_2^{(NBTCs)} = (A - 2 \cdot c_2 + c_1) / (B + 2 \cdot d_2)$. Under these assumptions, the market-clearing price is $P^{(NBTCs)} = (d_2 \cdot (A + c_1) + c_2 \cdot B) / (B + 2 \cdot d_2)$. According to this market-clearing price and the optimal output levels, the producer surplus at node 1 is $PS_1^{(NBTCs)} = (B \cdot (c_2 - c_1) + d_2 \cdot (A - c_1))^2 / (B \cdot (B + 2 \cdot d_2)^2)$, and the producer surplus at node 2 is $PS_2^{(NBTCs)} = (d_2 \cdot (A - 2 \cdot c_2 + c_1))^2 / (2 \cdot (B + 2 \cdot d_2)^2)$.

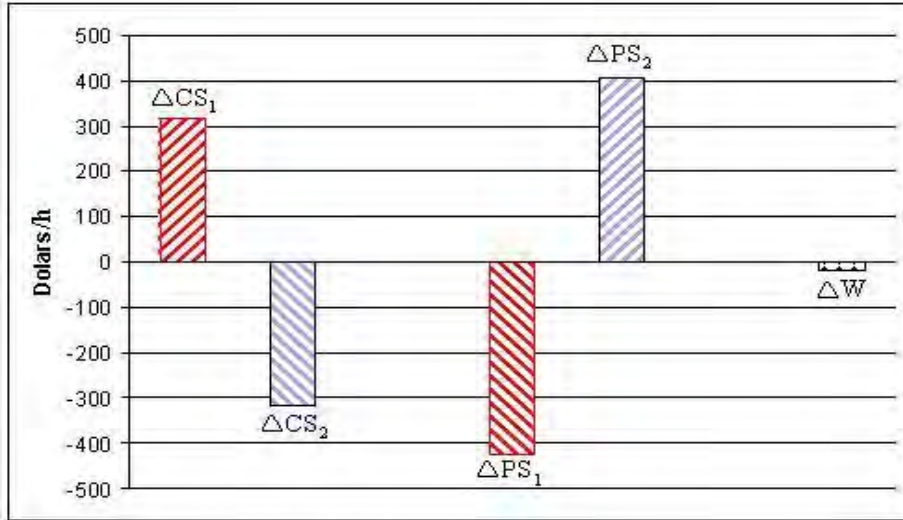

Figure 4: Effects on consumers and producers of building a non-binding-capacity line between both nodes, assuming that the investment cost is negligible

It is interesting to study the behavior of our two-node network under perturbation of some supply and/or demand parameters. Next, we present a sensitivity analysis of the optimal network expansion decision with respect to the marginal cost of supply at node 1, c_1 .

Figure 5 shows the changes in the optimal network expansion plan, under each of the four optimization objectives we have considered, as we vary the marginal cost of generation at node 1 (keeping all other parameters unaltered and assuming that investment costs are negligible).

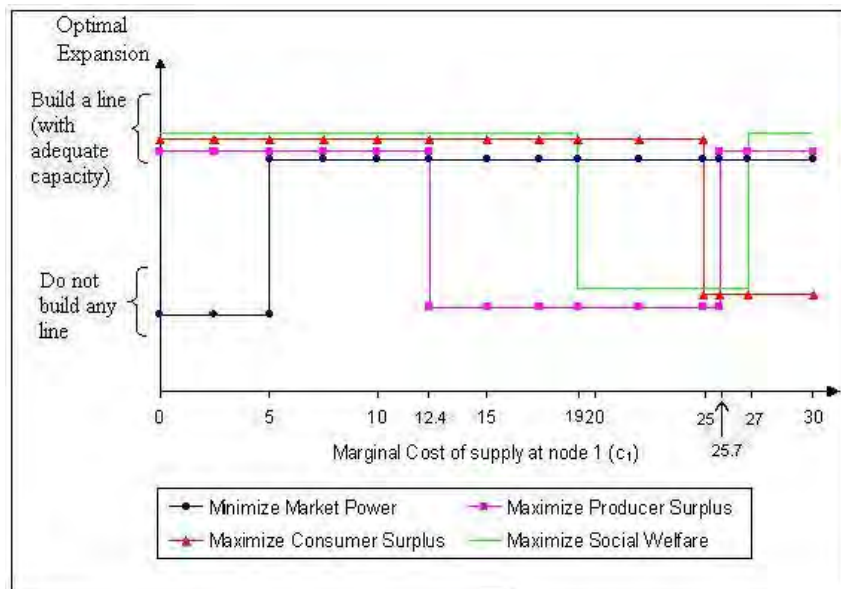

Figure 5: Sensitivity to the marginal cost of supply at node 1 in the two-node network

We note that none of the optimizing objectives leads to a consistent optimal expansion for all values of the parameter c_1 . Moreover, this figure demonstrates that only for values of c_1 between \$5 /MWh and \$12.4 /MWh the four optimization objectives lead to the same optimal expansion plan. For c_1 higher than \$5 /MWh, the competition among generation firms intensifies under the NBTCS, forcing the monopolist at node 1 to reduce its retail price (i.e., $P_1^{(NBTCS)} < P_1^{(SSNS)}$), thus decreasing the monopolist's local market power. Moreover, for c_1 lower than \$12.4 /MWh, under the SSNS, the monopolist at node 1 sets a retail price lower than the equilibrium price at node 2 (i.e., $P_1^{(SSNS)} < P_2^{(SSNS)}$). Thus, under the NBTCS, there is a net transmission flow from node 1 to node 2 which improves producer surplus, consumer surplus, and social welfare with respect to the SSNS.

Another interesting observation from Figure 5 is that the optimal network expansion plan, under most of the optimization objectives, is highly sensitive to the marginal cost of generation at node 1 when this parameter has values between \$25 /MWh and \$27 /MWh.

We also performed a sensitivity analysis of the optimal network expansion plan with respect to some demand parameters. Modifying some of the demand function parameters, while keeping all supply parameters unaltered, leads to qualitative results that are similar to those observed when we vary the supply cost at node 1. Such analysis shows that the optimal expansion plan under each of the four optimization objectives is highly sensitive to the demand structure.

3.3 Adverse interaction of market power and connectivity

It is interesting to note that, in the two node example introduced in the previous subsection, building the transmission line between the two nodes will result in flow from the expensive generation node to the cheap node, so that the transmission line cannot realize the potential *gains from trade* between the two nodes. On the contrary such flow decreases social welfare due to the exporting of power from an expensive-generation area into a cheap-generation area. This phenomenon is due to the exercise of market power by the generator at node 1, who finds it advantageous to let the competitive fringe increase its production by exporting power to the cheap node, in order to sustain a higher market price. In economic trade theory, *gains from trade* is defined as the improvement in consumer incomes and producer revenues that arise from the increased exchange of goods or services among the trading areas (countries in international trade studies). It is well understood that, in absence of local market power (e.g., excluding all monopoly rents), the trade between areas must increase the total utility of all the areas combined. That is, *gains from trade* must be a non-negative quantity. This rationale underlines common wisdom that prevailed in a regulated environment justifying the construction of transmission between cheap and expensive generation nodes on the grounds of reducing energy cost to consumers. However, as our example demonstrates, such rationale may no longer hold in a market-based environment where market power is present. Moreover, if we excluded monopoly rents from our social welfare calculations, then we would obtain zero gain from trade, in agreement with the *gains from trade* economic principle. However, even in that case, our example would still help us to illustrate that transmission expansions have distributional impacts, which create conflicts of interests among market participants.

Figure 6 and Figure 7 assists us to explain the results obtained in our particular example. These two figures show the price-quantity equilibria at each node under the two considered scenarios. In these figures, the solid lines represent the equilibria under the SSNS while the dotted lines correspond to the equilibria under the NBTCS.

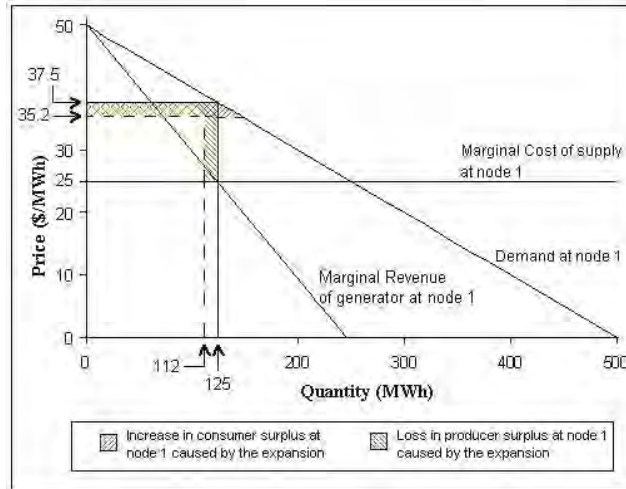

Figure 6: Equilibrium at node 1 under both the SSNS and the NBTCS

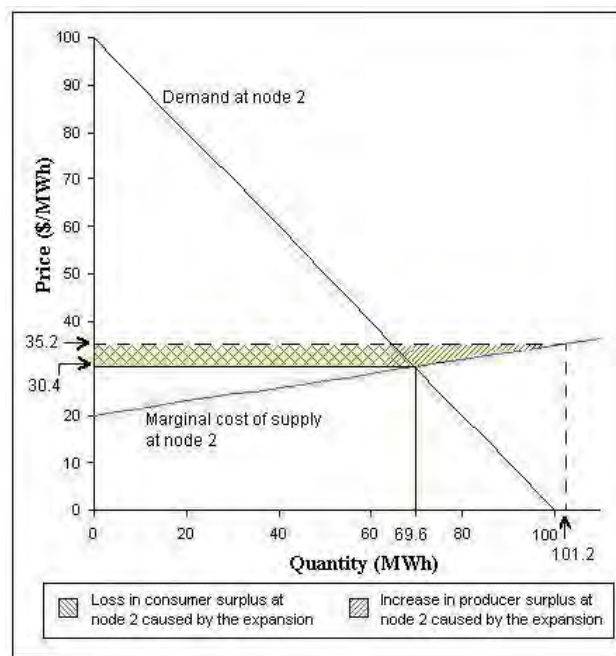

Figure 7: Equilibrium at node 2 under both the SSNS and the NBTCS

One way to explain the results obtained in the example presented in this section is through the distinction between two different effects due to the construction of the non-

binding-capacity transmission line. On one hand, competition among generation firms increases, thus forcing the firm located at node 1 to decrease its retail price with respect to the SSNS. On the other hand, the transmission expansion causes a substitution (in production) of some low-cost power by more expensive power as result of the exercise of local market power.

The construction of the non-binding-capacity transmission line allows market participants to sell/buy power demanded/produced far away. This characteristic encourages competition among generation firms. In our example, the introduction of competition entails a decrease in the retail price at node 1 with respect to the SSNS. As shown in Figure 6, this price reduction causes an increase in the node 1's consumer surplus (because the demand at node 1 increases) and a reduction in the profit of the monopolist at node 1 with respect to the SSNS.

Moreover, because of the ability to exercise local market power, the monopolist at node 1 can reduce its output (although the demand at node 1 increases with respect to the SSNS) and keep a retail price higher than the SSNS market-clearing price at node 2 in order to maximize its profit under the NBTCS. As this happens, the node 2's firms increase their output levels (increasing both the generation marginal cost and the retail price at node 2 with respect to the SSNS equilibrium) up to the point in which the retail prices at both nodes are equal (assuming the transmission constraint is not binding) and the total demand is met, NBTCS equilibrium. As shown in Figure 4, at this new equilibrium, the producer surplus at node 2 increases while the consumer surplus at node 2 decreases with respect to the SSNS. In other words, because the power generation at node 1 is cheaper than the one at node 2 for the relevant output levels, the exercise of local market power by the node 1's firm causes a substitution of some of the low-cost power generated at node 1 by more expensive power produced at node 2 to meet demand. This out-of-merit generation, caused by the transmission expansion, reduces social welfare with respect to the SSNS. It is also worth noting that the above, seemingly counter intuitive result, is a manifestation of the so called "theorem of the second best" in welfare economics which tells us that with two market imperfections (in this case, market power and no access) fixing one problem (by creating access) may actually make things worse.

3.4 Policy implications

First, we observed that the optimal expansion of a network depends on the optimizing objective utilized and can be highly sensitive to supply and demand parameters. Even when the optimizing objective is clearly determined, the optimal network expansion plan changes depending on the cost structure of the generation firms. However, generation costs are typically uncertain and depend on factors like the available generation capacity or the generation technology used, which in turn affect the optimal network investment plan. It follows that the interrelationship between generation and transmission investments should be considered when evaluating any transmission expansion project. Accounting for such interactions has been part of the integrated resource planning paradigm that prevailed under the regulated vertically integrated electricity industry, but is no longer feasible in the restructured industry. Second, our analysis shows that transmission investments have important distributional impact. While some transmission investments can greatly benefit some market participant, they may harm some other

constituents. Consequently, policy makers looking after socially efficient network expansions should be aware of the distributional impact of merchant investments. Moreover, the dynamic nature of power systems entails changes over time of not only demand and supply structures, but also the mix of market participants, which adds complexity to the valuation of merchant transmission expansion projects. Even when a merchant investment appears to be beneficial under the current market structure, the investment could become socially inefficient when future generation and transmission plans and/or demand forecasts are considered.

3.5 Documentation

The material presented in Section 3 is documented in a number of publications and conference presentations as follows:

Sauma Enzo and Shmuel Oren, “Economic Criteria for Planning Transmission Investment in Restructured Electricity Markets”, *IEEE Transactions on Power Systems, Special issue on Transmission Investment, Pricing and Construction*, Vol. 22, No. 4, (2007) pp. 1394-1405

Sauma Enzo E. and Shmuel S. Oren., “Alternative Economic Criteria and Proactive Planning for Transmission Investment in Deregulated Power Systems”, Working paper, September 2005. To appear as an IEEE book chapter

4. Investment Incentives for Transmission Investment and Cost Allocation

In the new competitive environment, the independent grid operator or *IGO*, be it an *ISO* or a *RTO*, has wide responsibilities for regional planning, including the development of transmission plans. However, the implementation of the plans is in the hands of current transmission owners or new transmission investors. Furthermore, any such plan is subject to scrutiny by stakeholders who may have conflicting interests and some of whom may be adversely affected by the plan. A generator in a load pocket, for instance, who commands a high locational marginal price for locally supplied energy, might be adversely affected by a transmission line that would increase imports into the load pocket. In this widely modified planning paradigm the transmission investments have, have failed to keep up with the steadily increasing load demands and the ever more intense utilization of the grid by an increasing number of transmission customers. The meager expansion/enhancement of the bulk power system grid is one of the most daunting challenges facing the industry. One way to overcome this sorry picture in transmission investment is through the provision of appropriate incentives for expansion/improvement of the grid. Such schemes must take into account the physical constraints in the transmission grid and the financial and market realities of the new environment. This issue is addressed in two papers.

4.1 A cooperative game approach to incentivizing transmission investment

This subsection describes an incentive mechanism design for stimulating investment in the improvement/expansion of the transmission network in the competitive market environment. We also provide a comparison of investment results using two different models for transmission planning and investment in electricity markets. We have considered two different models for transmission planning and investment in electricity markets. The first model is a centralized model, where the costs of expansion are publicly known and the investment is performed by the *IGO*. The second model is the decentralized expansion of the network in which, the investors build new transmission assets according to the incentives provided by the *IGO*. These incentives are based on cooperative game theory and are calculated using the Shapley value formula based on the increase in social welfare produced by the combined effect of new transmission assets. The results are illustrated by means of representative numerical examples.

Background

Network expansion is by nature a very complex multi-period and multi-objective optimization problem. Its nonlinear nature, the lumpiness of transmission resources and the inherent uncertainty of future developments constitute major complicating factors. Its solution is very difficult, even under the centralized decision making paradigm. In the competitive electricity market environment, characterized by decentralized decision making, the formulation of the transmission expansion/improvement problem requires some important modifications, to incorporate the consideration of the interaction between

Financial Transmission Rights (*FTR*) and market power, the analysis of merchant transmission investment, and the effect of lumpiness and imperfect competition. In the planning of new transmission asset additions, the objectives of market efficiency improvement and social welfare maximization compete with those of profit maximization of the individual players and the investors. Typical situations requiring transmission asset investments stem from the need to efficiently address congestion relief requirements by making the necessary improvements to the transmission network. Such investments impact each market player differently, some faring better and some worse as a result of the provided congestion relief.

Other than the lumpiness of transmission investments, the free rider problem arising from the public goods property of transmission assets, the lack of clarity and consistency in regulatory policy, the lack of regional institutions and the need for state approval are among the key reasons of transmission underinvestment. The sluggishness of transmission construction is because mismatches between those benefiting from the new facilities and those paying for them are often such as to deter the new facilities from getting built. Therefore, effective procedures to ensure the timely recovery of transmission investments are sorely needed in order to ensure that the investment costs will be reimbursed on a timely basis, thereby providing sufficient incentives to site and construct the new assets.

Incentives formulated as reimbursement schemes are well known in the economics literature given to the seminal work of Vickrey and the extensions to other economic problems. These schemes are based on the notion that the remuneration is a function of the difference in the social welfare with and without the added investment. In transmission planning, the formulation of investment incentives needs to pay careful attention to the network effects of the existing transmission grid and the extensive interactions among individual investments. As such, incentive mechanisms, which reward those investors whose investments lead to increased total social welfare, are appropriate for these purposes. The objective of this task was to develop such incentive mechanisms to stimulate investment in the expansion/improvement of the transmission network in the competitive market environment.

New transmission assets can produce improvements in the network, such as congestion relief, that are beneficial to some or, even in certain cases, all transmission customers. Cooperative game theory allows participants to jointly create added value and to be compensated based upon their contribution to the welfare of the system. Among the cooperative value allocation methods, the Shapley value has the attractive attribute of uniqueness, which serves as a basis for sharing benefits among all the investors. We modeled the transmission network investment problem as a cooperative game and constructed an incentive mechanism to allocate the new value created by the network expansion. In this game, the players are the investors in transmission assets and the *IGO* reimburses these investors by offering them all or part of the social welfare increase due to their investments. The investors receive these incentive offers and send their rate of return requirements to the *IGO*. If their requirements are below the specified incentives,

the investors are invited to invest. The entire process is iterative and stops when there are no more investors willing to add transmission assets or improvements.

Formulation of incentives for decentralized transmission asset investments

We describe the incentive scheme for encouraging private investment in the improvement and expansion of the transmission grid in the competitive electricity market environment. Without incentives, the necessary enhancements to the existing grid are not moving forward. To create these incentives, we propose a decentralized transmission asset investment model in which the new assets – be the new transmission facilities or improvements of the existing grid – are built by private investors. They get to recover their investments with their specified rate of return with the *IGO* determining the amount of money given investors dependent on the overall improvement of social welfare.

We use a pool-based system to model the market and use the maximization of social welfare as the objective of the optimization of solving the security-constrained market problem. For the investment problem, the decentralized transmission investment model determines the incentives to the investors whose assets improve the network. The set of investments, which result in the maximum increase in benefits to the network. The addition of new assets is based on the *value* that a new asset brings to the system. We measure the value of a transmission asset as the increase in social welfare that a new asset (or a combination of new assets) brings to the network over the planning horizon, above that of the pre-investment scenario, where no new assets are considered. By formulating the investment problem as a cooperative game, with the investors in transmission assets as the players, the *IGO* reimburses these investors by offering them all or part of the social welfare increase that they produce when they are selected. In effect, this game is a cooperative value allocation game, where the players are rewarded as a function of the improvement that they can bring to the system. The Shapley value of a player in this game is the increase of the coalition surplus brought by the player to a coalition. The payment to each investor is commensurate with the increase in social welfare that the investment brings to the system. The investors receive these incentive offers and send their rate of return requirements to the transmission planner. If their requirements are lower than the incentives, then they are invited to invest. The entire process is iterative until there are no more investors willing to build transmission assets. The game-theoretic formulation brings valuable insights into the transmission investment topic. An attractive characteristic is the flexibility of the formulation as it allows the incorporation of various constraints. The imposition of a practical limitation such as a budget constraint is incorporated in a straightforward way into the formulation.

The Shapley value allocation scheme explicitly represents the interactions between the *IGO* and the investors. In the initial step, the *IGO* selects the subset of investors to participate in building transmission assets. Then, the *IGO* runs the decentralized investment model under the imposed budget constraints to determine the best set of candidates. The *TP* evaluates the increase in social welfare with respect to the pre-investment scenario for each combination of the selected subset of investors determined by the decentralized investment model and calculates the Shapley values. The latter are compared to the investors' requirements. For a single asset investor, if the Shapley value

is above the requested payment, the *IGO* accepts the investor offer to add the transmission asset with a payment in line with the investor's request. Otherwise, the *IGO* informs the investor that he is not selected to participate in the addition of new assets. For a non-selected investor with more than one transmission asset, the *IGO* requests the investor to withdraw at least one of the offered transmission assets in the next round. The *IGO* again runs the decentralized investment model and repeats the iterations until the game ends when there are no more investors willing to add transmission assets. The Shapley value incorporates efficiency and fairness principles and its application allows us to analyze the combined effects of simultaneous investments and also remunerate only the investors that truly improve the social welfare.

Numerical testing of incentive scheme

We tested the proposed incentive scheme by investigating various investment alternatives in two systems – the well-known Garver six-bus network and the IEEE 24-bus RTS. The numerical results not only effectively illustrate the capabilities of the proposed mechanism and its flexibility, but allowed us to also gain insights into the development of network improvements through the formulation proposed. We used the SBB solver in the GAMS software package to solve all the optimization models and computed the Shapley value allocations with the Cooperative Game Toolbox in MATLAB. The running times for all the case studies are acceptably fast.

The testing of various expansion alternatives under a range of parameter sensitivities and multiple scenarios provide good insights into the development of network improvement strategies for different investors. The experience to date provides a solid basis for the extension of the numerical testing on larger networks. The implementation of simulation tools for larger-scale networks is a topic of future work.

Conclusions

The thrust of this task was to explore the development of incentives for transmission asset investment. We developed a formulation of the transmission investment problem in a cooperative game framework. Cooperative game theory allows participants to jointly create added value and to receive compensation based upon the individual contribution to the improvement of the social welfare of the system. The incentive formulation is obtained from the decentralized transmission asset investment model and is based on the value added to the social welfare by an asset investment. The numerical results from testing the mechanism via simulation on two small systems provide good insights into the system improvements attainable by different investment alternatives. This work is documented in the paper:

J. Contreras, G. Gross, I. Ruiz-Gomez and J. M. Arroyo, " A Scheme For Incentivizing Investments And Cost Sharing In Transmission Enhancements," Proceedings of PSCC 2008, Glasgow, United Kingdom, July 14-18, 2008.

4.2 Aligning stakeholders incentive with the social objectives through FTR allocation

In this subsection we examine the incentives that generation firms have in restructured electricity markets for supporting long-term transmission investments. In particular, we study whether generation firms, which arguably play a dominant role in the restructured electricity markets, have the incentives to fund or support incremental social-welfare-improving transmission investments. We examine this question in a two-node network and explore how such incentives are affected by the ownership of financial transmission rights (FTRs) by generation firms. In the analyzed two-node network, we show both (i) that the net exporter generation firm has the correct incentives to increase the transmission capacity incrementally up to a certain level and (ii) that, although a policy that allocates FTRs to the net exporter generation firm can be desirable from a social point of view, such a policy would dilute the net-importer-generation-firm's incentives to support transmission expansion. Moreover, if all FTRs were allocated or auctioned off to the net exporter generation firm, then it is possible to increase both consumer surplus and social welfare while keeping the net exporter generation firm revenue neutral.

Oligopolistic equilibrium in congestion prone transmission networks and the effect of FTR allocation on investment incentives and market power

In the previous section we observed that transmission expansions generally have distributional impacts, which could potentially create conflicts of interests among the affected parties. The key issue is that, while society as a whole may benefit from incremental mitigation of congestion, some parties may be adversely affected. In this subsection we will explore how FTR allocation may affect the distribution of gain and pain among market participants and hence their incentive to support or oppose transmission expansion projects. Our analysis is based on comparative statics of an interior oligopolistic equilibrium and hence is only relevant to small incremental changes in transmission capacity. The analysis builds on the work of Bornstein *et.al*¹⁵ who identified three possible regimes in the strategic interaction among oligopolistic seller across a congestion prone transmission link. The strategic interaction among firms occurs at the intersection of their best response function depicted in Figure 8 below. The possibility of congestion creates discontinuities in the reaction functions and depending on the transmission line capacity we can have one of three regimes: 1) An unconstrained equilibrium when capacity is large enough so that congestion is unlikely, 2) A passive/aggressive (P/A) equilibrium where the line is permanently congested and the firms behave as monopolists with respect to their local demand shifted by imports or exports, 3) An intermediate region where a pure strategy equilibrium may not exist due to the discontinuous best response functions. We will focus on the P/A regime which is the more interesting one and is likely to create contention regarding a proposed transmission project and competitive behavior of the generators.

¹⁵Bornstein S, Bushnell J, Stoft S. The Competitive Effects of Transmission Capacity in a Deregulated Electricity Industry. RAND Journal of Economics 2000; 31(2); 294-325.

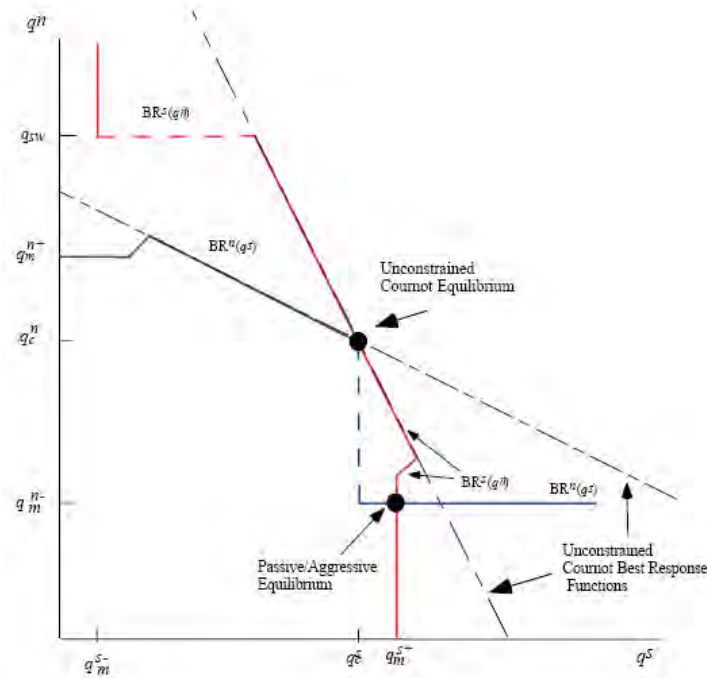

Figure 8: Best response functions

In the absence of FTRs we have shown that an incremental transmission expansion in the P/A regime will increase profits to the exporting generation firm and reduce profits of generators on the import side of the congested line. Hence even if transmission expansion might be socially beneficial it could face opposition. Introducing transmission right in the form of FTR modifies the incentives of generators on both sides with regard to transmission expansion. A one MW FTR entitle the holder to the nodal price differences between the respective locations. Hence, holding FTRs enhances exporters profits due to transmission expansion and incentivizes the exporter to try increase the nodal price difference between the nodes. To do so the exporter may increase local production so as to reduce the local nodal price. In other words giving FTRs to the exporter not only increases its profits due to transmission expansion but also motivates the exporter to increase production and forgo market power. On the other hand FTRs in the hand of the exporters increases the losses to the import side generators due to transmission expansion and thus dilutes potential support if any for the expansion if there was such support. Unfortunately, that does not automatically imply that FTRs should be held by the importers since the effect of giving FTRs to generators on the import side is ambiguous. It is not clear whether the FTR gains will offset the import side generators losses due to transmission expansion.

Conclusion

By varying the fraction of FTRs held by exporting generators we have shown that the larger that proportion is, the stronger the cheapgen's incentive to increase its production (and, in this way, to decrease its nodal price). Furthermore, the larger the proportion is of FTRs held by the exporting generators, the weaker is the incentive of generators on the import side to withhold production (and, in this way, to raise the nodal price on that side).

Accordingly, when the exporters hold all the available FTRs, the consumers located at that node benefit the most from the nodal price reduction while the surplus of the consumers located at the import node remains at the benchmark's level (because the import side generators have no extra incentive to reduce production and increase the local price). Consequently, we conclude that allocating all the FTRs to the export side producers maximizes both consumer surplus and social welfare although it may not enlist support on the import side for transmission expansion. This work is documented in the papers:

Sauma Enzo E. and Shmuel S. Oren., "Aligning Generators' Interests with Social Efficiency Criteria for Transmission Upgrades in an LMP Based Market", *Proceeding of the IEEE PES Annual Meeting*, Tampa, Florida, June 24-28, 2007.

Sauma Enzo and Shmuel Oren, "Do Generation Firms in Restructured Electricity Markets Have Incentives to Support Social-Welfare-Improving Transmission Investments?", *Energy Economics*, In Press, available online 4 February 2009

5. A Proactive Planning Paradigm for Economic Assessment of Transmission Expansion Projects

As we recognized in the previous section, considering the interactions between the transmission and the generation systems is a crucial element in the analysis of the optimal way to expand a network. Essentially, the true value of transmission is a measure of the opportunity cost since transmission capacity allows geographically dispersed agents to gain from trading. Yet, due to the physical laws of electricity, there are both operational and investment complementarities and substitutabilities between the generation and transmission assets. If a generator creating congestion in a line were to expand its generation capacity in order to gain more of the equilibrium market share, this would aggravate the congestion over the line and would increase the value of additional transmission capacity. Thus, these two types of capacity, although physically very different, are complementary to one another. At the same time, if a generator providing counterflow to the previous line were to expand its generation capacity, then this would result in a decreased transmission value. In this situation, both types of capacity are substitutable.

A generator making an investment to increase its competitiveness or a system operator augmenting the transmission capacity of a link will change the electricity market equilibrium and, consequently, the state of system congestion for everyone. Since the institutional reforms mandate a dispersion of ownership, the resulting market structure is characterized by external effects to investment decisions, as well. A key question is whether the transmission congestion management protocols designed to force generators to internalize their external dispatching effects also counter this investment externality.

In this section, we propose a three-period model to examine how the exercise of local market power by generation firms affects both the generating firms' incentives to invest in new generation capacity and the equilibrium investment between the generation and the transmission sectors. This model is based on the idea that the exercise of market power by generators can reduce their incentives to add generation capacity, which ultimately affect the social value of transmission. The model structure is a mathematical program subject to an equilibrium problem with equilibrium constraints (MPEPEC), in which the network planner solves a mathematical programming problem subject to the equilibrium of generation capacity expansion (where each firm solves a mathematical programming problem with equilibrium constraints (MPEC)).

In this section, we show that a "proactive" network planner (i.e., a network planner who plans transmission investments in anticipation of generation investments so that it is able to induce a more socially-efficient Nash equilibrium of generation capacities) can recoup some of the welfare lost due to the unbundling of the generation and the transmission investment decisions by proactively expanding transmission capacity. Conversely, we show that a "reactive" network planner (i.e., a network planner who plans transmission investments only considering the currently installed generation capacities and, in this way, ignoring the interrelationship between the transmission and the generation

investments) foregoes this opportunity. We illustrate our results using a 30-bus network example.

5.1 The proactive transmission investment model

In this sub-section, we introduce a three-period model for studying how generation firms’ local market power affects both the firms’ incentives to invest in new generation capacity and the equilibrium investment between the generation and the transmission sectors. The basic idea behind this model is that the interrelationship between the generation and the transmission investments affects the social value of the transmission capacity.

Model assumptions

The model does not assume any particular network structure, so that it can be applied to any network topology. Moreover, we assume that all nodes are both demand nodes and generation nodes and that all generation capacity at a node is owned by a single firm. We allow generation firms to exercise local market power and assume that their interaction can be characterized through Cournot competition, i.e., firms choose their production quantities so as to maximize their profit with respect to the residual demand function while taking the production quantities of other firms and the dispatch decisions of the system operator as given. Furthermore, the model allows many lines to be simultaneously congested. Although this fact makes the analysis complex, this is a very important feature of real network operations.

The model consists of three periods, as displayed in Figure 9. We assume that, at each period, all previous-periods actions are observable to the players making a decision. That is, we define the proactive transmission investment model as a “complete- and perfect-information” game¹⁶ and the equilibrium as “sub game perfect”.

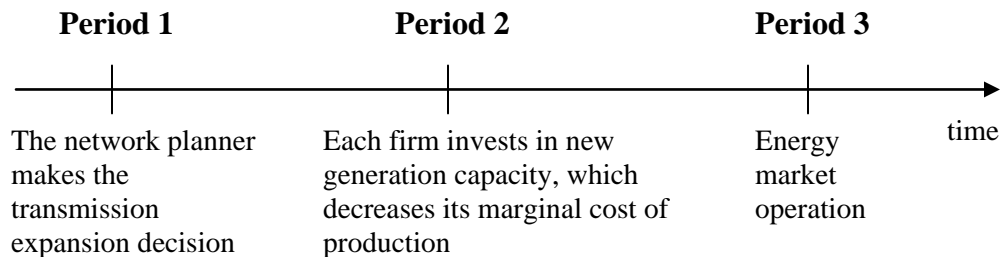

Figure 9: Three-period model for proactive transmission investment

This model is static. That is, the model parameters (demand and cost functions, electric characteristics of the transmission lines, etc.) do not change over time (among periods). Accordingly, the model can be perceived as annualized. We assume both that the time between period 1 and period 3 corresponds to a year and that the time between period 1 and 2 is almost negligible. Hence the investment costs correspond to the payments of

¹⁶ A “complete- and perfect-information” game is defined as a game in which players move sequentially and, at each point in the game, all previous actions are observable to the player making a decision.

interest to the bank lending the money (financial investment costs). This assumption makes sense in the real world because both generation and transmission investments are, in general, sufficiently large to guarantee that every investor must borrow money from a bank or other lender in order to physically cover the investment costs. Thus, the investor's proper annual cost of the investment is the annualized mortgage rate paid to the lender.

We now explain the model backwards. The last period (period 3) represents the energy market operation. That is, in this period, we compute the equilibrium quantities and prices of electricity over given generation and transmission capacities. We model the energy market equilibrium in the topology of the transmission network through the DC approximation of Kirchhoff's laws. Specifically, flows on lines can be calculated by using the power transfer distribution factor (PTDF) matrix, whose elements, give the proportion of flow on a particular line resulting from an injection of one unit of power at a particular node and a corresponding withdrawal at an arbitrary (but fixed) slack bus. Different PTDF matrices with corresponding probabilities characterize uncertainty regarding the realized network topology in the energy market equilibrium (the generation and transmission capacities are subject to random fluctuations (contingencies) that are realized in period 3 prior to the production and redispatch decisions by the generators and the system operator). We will assume that the probabilities of all credible contingencies are public knowledge.

We model the energy market equilibrium as a subgame with two stages. In the first stage, Nature picks the state of the world (and, thus, settles the actual generation and transmission capacities as well as the shape of the demand and cost functions at each node). In the second stage, firms compete in a Nash-Cournot fashion by selecting their production quantities, while taking into consideration the simultaneous import/export decisions of the system operator whose objective is to maximize social welfare while satisfying the transmission constraints.

In the second period, each firm (generator) invests in new generation capacity, which lowers its marginal cost of production at any output level. For the sake of tractability we assume that generators' production decisions are not constrained by physical capacity limits. Instead we allow generators' marginal cost curves to rise smoothly so that production quantities at any node will be limited only by economic considerations and transmission constraints. In this framework generation expansion is modeled as "stretching" the supply function so as to lower the marginal cost at any output level and thus increase the amount of economic production at any given price. Such expansion can be interpreted as an increase in generation capacity in a way that preserves the proportional heat curve or alternatively assuming that any new generation capacity installed will replace old, inefficient plants and, thereby, increase the overall efficiency of the portfolio of plants in producing a given amount of electricity. This continuous representation of the supply function and generation expansion serves as a proxy to actual supply functions that end with a vertical segment at the physical capacity limit. Since typically generators are operated so as not to hit their capacity limits (due to high heat rates and expansive wear on the generators) our proxy should be expected to produce realistic results. The return from the generation capacity investments made in period 2

occurs in period 3, when such investments enable the firms to produce electricity at lower cost and sell more of it at a profit. In our model, we assume that, in making their investment decisions in period 2, the generation firms are aware to the transmission expansion from period 1 and form rational expectations regarding the investments made by their competitors and the resulting market equilibrium in period 3. Thus the generation investment and production decisions by the competing generation firms are modeled as a two stage subgame perfect Nash equilibrium.

Finally, in the first period, the system operator (or network planner), which we model as a Stackelberg leader in this three-period game, evaluates different projects to expand the transmission network while anticipating the generators' and the system operator's response in periods 2 and 3. In particular, we consider here the case where the network planner evaluates a single transmission expansion decision, but the proposed approach can be applied to more complex investment options.

Because the system operator under this paradigm anticipates the response by the generators, optimizing the transmission investment plan will determine the best way of inducing generation investment so as to maximize the objective function set by the network planner. We therefore will use the term "proactive system operator" to describe such a planning approach which results in outcomes that although they are still inferior to the integrated resource planning paradigm, they often result in the same investment decisions. In this model, we limit the transmission expansion decision to expanding the capacity of any one line according to some specific transmission-planning objective. Our model allows both the upgrades of existing transmission lines and the construction of new transmission lines. In the case of upgrading an existing line, we assume that the upgrade does not alter the original PTDF matrices, but only the thermal capacity of the line (for instance, this would be the case if, for the expanded line, we replaced all the wires by new ones (with new materials such as "low sag wire") while using the same existing high-voltage towers). On the other hand, in the case of building a line at a new location, we consider that the PTDF matrices change according to both the network structure and the electric characteristics of the new line.

Since the energy market equilibrium will be a function of the thermal capacities of all constrained lines, the Nash equilibrium of generation capacities will also be a function of these capacity limits. The proactive system operator, then, has multiple ways of influencing this Nash equilibrium by acting as a Stackelberg leader who anticipates the equilibrium of generation capacities and induces generation firms to make more socially optimal investments.

We further assume that the generation cost functions are both increasing and convex in the amount of output produced and decreasing and convex in generation capacity. Furthermore, as we mentioned before, we assume that the marginal cost of production at any output level is decreasing as generation capacity increases. Moreover, we assume that both the generation capacity investment cost and the transmission capacity investment cost are linear in the extra-capacity added. We also assume downward-sloping linear demand functions at each node. To further simplify things, we assume no wheeling fees.

Model notation

Sets	{	<ul style="list-style-type: none"> - N: set of all nodes - L: set of all transmission lines - C: set of all states of contingencies - N_G: set of generation nodes controlled by generation firm G - Ψ: set of all generation firms
Decision variables	{	<ul style="list-style-type: none"> - q_i^c: quantity generated at node i in state c - r_i^c: adjustment quantity into/from node i by the system operator in state c - g_i: expected generation capacity of facility at node i after period 2 - f_ℓ: expected thermal capacity limit of line ℓ after period 1
Parameters	{	<ul style="list-style-type: none"> - g_i^0: expected generation capacity of facility at node i before period 2 - f_ℓ^0: expected thermal capacity limit of line ℓ before period 1 - g_i^c: generation capacity of facility at node i in state c, given g_i. - f_ℓ^c: thermal capacity limit of line ℓ in state c, given f_ℓ. - $P_i^c(\cdot)$: inverse demand function at node i in state c - $CP_i^c(q_i^c, g_i^c)$: production cost function of the generation firm located at node i in state c - $CIG_i(g_i, g_i^0)$: cost of investment in generation capacity at node i to bring expected generation capacity to g_i. - $CI_\ell(f_\ell, f_\ell^0)$: cost of investment in line ℓ to bring expected transmission capacity to f_ℓ. - $\phi_{\ell, i}^c(L)$: power transfer distribution factor on line ℓ with respect to a unit injection/withdrawal at node i, in state c, when the network structure is given by L.

Mathematical formulation

We start by formulating the third-period problem. In the first stage of period 3, Nature determines the state of the world. In the second stage, for a given state c, generation firm G ($G \in \Psi$) solves the following profit-maximization problem:

$$\begin{aligned} \text{Max}_{\{q_i^c, i \in N_G\}} \quad & \pi_G^c = \sum_{i \in N_G} \left\{ P_i^c(q_i^c + r_i^c) \cdot q_i^c - CP_i^c(q_i^c, g_i^c) \right\} \\ \text{s.t.} \quad & q_i^c \geq 0 \quad , \quad i \in N_G \end{aligned}$$

Simultaneously with the generators' production quantity decisions, the system operator solves the following welfare maximizing redispatch problem (for the given state c):

$$\begin{aligned} \text{Max}_{\{r_i^c, i \in N\}} \Delta W^c &= \sum_{i \in N} \left\{ \int_0^{r_i^c} P_i^c(q_i^c + x_i) dx_i \right\} \\ \text{s.t.} \quad \sum_{i \in N} r_i^c &= 0 \\ -f_\ell^c &\leq \sum_{i \in N} \phi_{\ell,i}^c(L) \cdot r_i^c \leq f_\ell^c, \quad \forall \ell \in L \\ q_i^c + r_i^c &\geq 0, \quad \forall i \in N \end{aligned}$$

Given that we assume no wheeling fees, the system operator can gain social surplus, at no extra cost, by exporting some units of electricity from a cheap-generation node while importing them to other nodes until the prices at the nodes are equal, or until some transmission constraints are binding.

The previously specified model assumptions guarantee that the optimization problems above characterizing the behavior of generation firms and the ISO are concave programming problems, which implies that first order necessary conditions (i.e. KKT conditions) are also sufficient. Consequently, to solve the period-3 problem (energy market equilibrium), we can just jointly solve the KKT conditions of the problems defined for all $G \in \Psi$, which together form a linear complementarity problem (LCP) that can be easily solved with off-the-shelf software packages.

The KKT conditions for the generation firms' problems are:

$$\begin{aligned} P_i^c(q_i^c + r_i^c) + P_i^{c'}(q_i^c + r_i^c) \cdot q_i^c - \frac{\partial CP_i^c(q_i^c, g_i^c)}{\partial q_i^c} + \gamma_i^c &= 0, \quad \forall i \in N_G, G \in \Psi, c \in C \\ \gamma_i^c \cdot q_i^c &= 0, \quad \forall i \in N_G, G \in \Psi, c \in C \\ q_i^c &\geq 0, \quad \forall i \in N_G, G \in \Psi, c \in C \\ \gamma_i^c &\geq 0, \quad \forall i \in N_G, G \in \Psi, c \in C \end{aligned}$$

where γ_i^c represent the Lagrange multipliers to the non-negativity constraints.

The KKT conditions for the ISO problem are:

$$P_i^c(q_i^c + r_i^c) + \alpha^c + \sum_{\ell \in L} (\lambda_{\ell^-}^c - \lambda_{\ell^+}^c) \cdot \phi_{\ell,i}^c(L) + \beta_i^c = 0, \quad \forall i \in N, c \in C$$

$$\begin{aligned}
\sum_{i \in N} r_i^c &= 0, \quad \forall c \in C \\
-f_\ell^c &\leq \sum_{i \in N} \phi_{\ell,i}^c(L) \cdot r_i^c \leq f_\ell^c, \quad \forall \ell \in L, c \in C \\
q_i^c + r_i^c &\geq 0, \quad \forall i \in N, c \in C \\
\lambda_{\ell-}^c \cdot \left(f_\ell^c + \sum_{i \in N} \phi_{\ell,i}^c(L) \cdot r_i^c \right) &= 0, \quad \forall \ell \in L, c \in C \\
\lambda_{\ell+}^c \cdot \left(f_\ell^c - \sum_{i \in N} \phi_{\ell,i}^c(L) \cdot r_i^c \right) &= 0, \quad \forall \ell \in L, c \in C \\
\beta_i^c \cdot (q_i^c + r_i^c) &= 0, \quad \forall i \in N, c \in C \\
\lambda_{\ell-}^c &\geq 0, \quad \forall \ell \in L, c \in C \\
\lambda_{\ell+}^c &\geq 0, \quad \forall \ell \in L, c \in C \\
\beta_i^c &\geq 0, \quad \forall i \in N, c \in C
\end{aligned}$$

where α^c is the Lagrange multiplier to the adjustment-quantities balance constraint, $\lambda_{\ell-}^c$ and $\lambda_{\ell+}^c$ are the Lagrange multipliers to the transmission capacity constraints, and β_i^c are the Lagrange multipliers to the non-negativity constraints in.

In period 2, each firm determines how much to invest in new generation capacity by maximizing the expected value of the investment (we assume risk-neutral firms) subject to the $N=1$ sets of KKT conditions characterizing the anticipated spot market equilibrium, in period 3. Since the investments in new generation capacity reduce the expected marginal cost of production, the return from the investments made in period 2 occurs in period 3. Thus, in period 2, firm G ($G \in \Psi$) solves the following optimization problem:

$$\begin{aligned}
&\text{Max}_{\{g_i, i \in N_G\}} E_c[\pi_G^c] - \sum_{i \in N_G} \{CIG_i(g_i, g_i^0)\} \\
&s.t. \quad \text{Spot market Equilibrium Conditions}
\end{aligned}$$

The problem defined above is known as a Mathematical Program with Equilibrium Constraints (MPEC) problem. Thus, the period-2 problem can be converted to an Equilibrium Problem with Equilibrium Constraints (EPEC), in which each firm faces (given other firms' commitments and the system operator's import/export decisions) an MPEC problem. However, this EPEC is constrained in a non-convex region and, therefore, we cannot simply write down the first order necessary conditions for each firm

and aggregate them into a large problem to be solved directly. In sub-section 5.3 of this we attempt to find an equilibrium point of this problem (rather than solve the optimization problem) for the particular case-study network, using sequential quadratic programming algorithms.

In the first period, the system operator (or network planner) evaluates different transmission expansion projects. In this period, the system operator is limited to decide which line (among both the already existing lines and some proposed new lines) it should upgrade, and what transmission capacity it should consider for that line, in order to maximizes the expected social welfare subject to the equilibrium constraints representing the anticipated actions in periods 2 and 3.¹⁷ Thus, in period 1, the system operator solves the following social-welfare-maximizing problem:

$$\text{Max}_{\ell, f_\ell} \sum_{i \in \mathbb{N}} \left\{ E_c \left[\int_0^{q_i^c + f_i^c} P_i^c(q) dq - CP_i^c(q_i^c, g_i^c) \right] - CIG_i(g_i, g_i^0) \right\} - CI_\ell(f_\ell, f_\ell^0)$$

s.t. Spot market Equilibrium Conditions and all optimality conditions of period - 2 problem

We do not attempt to solve this problem, but rather use this formulation as a framework for evaluating alternative predetermined transmission expansion proposals. For that purpose, we will only focus on the benefit portion of the objective function above, which can be contrasted with the transmission investment cost. In our case study, we will only compare benefits, which is equivalent to assuming that all candidate transmission investments have the same cost.

5.2 Transmission investment models comparison

In the previous sub-section, we formulated the transmission investment model used by the so-called proactive system operator (PSO). In this sub-section, we compare, from a theoretical point of view, the transmission investment decisions made by the PSO with those made under other three different network-planning paradigms. Next, we define and introduce mathematical formulations of these three network-planning paradigms.

Fully-vertically-integrated social planner (FVISP) model

In this model, we assume that the generation and the transmission sectors are jointly planned and operated by the FVISP. That is, the FVISP not only jointly plans generation and transmission expansions, but it also performs the energy market operations. Thus, the FVISP can incorporate the system-wide effects (operational and investment complementarities and substitutabilities between the generation and the transmission sectors), when making operating and investment decisions, in order to obtain a more socially efficient outcome.

¹⁷ No attempt is made to co-optimize the system operators' transmission expansion and redispatch decisions. We assume that the transmission planning function treats the real time redispatch function as an independent follower and anticipates its equilibrium response as if it was an independently controlled entity with no attempt to exploit possible strategic coordination between transmission planning and real time dispatch. One should keep in mind, however, that such coordination might be possible in a for-profit system operator enterprise such as in the UK.

The FVISP model consists of two periods: I and II. The last period (period II) corresponds to the centralized energy market operation and it is modeled as a subgame with two stages. In the first stage, Nature picks the state of the world. In the second stage, the FVISP chooses generation quantities and redispatch amounts (for the given state of the world) so that social welfare is maximized. That is, the FVISP solves the following social-welfare-maximizing problem (for given state c):

$$\begin{aligned} & \text{Max}_{\{q_i^c, r_i^c\}} \sum_{i \in \mathbf{N}} \left\{ \int_0^{q_i^c + r_i^c} P_i^c(q) dq - CP_i^c(q_i^c, g_i^c) \right\} \\ & \text{s.t.} \quad \sum_{i \in \mathbf{N}} r_i^c = 0 \\ & \quad -f_\ell^c \leq \sum_{i \in \mathbf{N}} \phi_{\ell, i}^c(\mathbf{L}) \cdot r_i^c \leq f_\ell^c \quad , \forall \ell \in \mathbf{L} \\ & \quad q_i^c + r_i^c \geq 0 \quad , \forall i \in \mathbf{N} \\ & \quad q_i^c \geq 0 \quad , \forall i \in \mathbf{N} \end{aligned}$$

The previously specified model assumptions guarantee that FVISP problem is a concave programming problem, which implies that first order necessary conditions (i.e. KKT conditions) are also sufficient.

In the first period (period I), the FVISP jointly decides the generation investment levels and the social-welfare-maximizing location and magnitude for the next transmission expansion, in anticipation of period II. Hence, in period I, the FVISP solves the following social-welfare-maximizing problem:

$$\begin{aligned} & \text{Max}_{\{g_i, \ell, f_\ell\}} \sum_{i \in \mathbf{N}} \left\{ E_c \left[\int_0^{q_i^c + r_i^c} P_i^c(q) dq - CP_i^c(q_i^c, g_i^c) \right] - CIG_i(g_i, g_i^0) \right\} - CI_\ell(f_\ell, f_\ell^0) \\ & \text{s.t.} \quad \text{the KKT conditions of period - II problem} \end{aligned}$$

or, equivalently:

$$\begin{aligned} & \text{Max}_{\{q_i^c, r_i^c, g_i, \ell, f_\ell\}} \sum_{i \in \mathbf{N}} \left\{ E_c \left[\int_0^{q_i^c + r_i^c} P_i^c(q) dq - CP_i^c(q_i^c, g_i^c) \right] - CIG_i(g_i, g_i^0) \right\} - CI_\ell(f_\ell, f_\ell^0) \\ & \text{s.t.} \quad \sum_{i \in \mathbf{N}} r_i^c = 0 \quad , \forall c \in \mathbf{C} \\ & \quad -f_\ell^c \leq \sum_{i \in \mathbf{N}} \phi_{\ell, i}^c(\mathbf{L}) \cdot r_i^c \leq f_\ell^c \quad , \forall \ell \in \mathbf{L}, \forall c \in \mathbf{C} \\ & \quad q_i^c + r_i^c \geq 0 \quad , \forall i \in \mathbf{N}, \forall c \in \mathbf{C} \\ & \quad q_i^c \geq 0 \quad , \forall i \in \mathbf{N}, \forall c \in \mathbf{C} \end{aligned}$$

Again our model assumptions guarantee that the above is a concave programming problem, which implies that first order necessary conditions are also sufficient. Consequently, to solve it, we can just solve the KKT conditions of the problem defined in which are:

$$\begin{aligned}
& P_i^c(q_i^c + r_i^c) - \frac{\partial CP_i^c(q_i^c, g_i^c)}{\partial q_i^c} + \beta_i^c + \gamma_i^c = 0, \quad \forall i \in N, c \in C \\
& P_i^c(q_i^c + r_i^c) + \alpha^c + \sum_{\ell \in L} (\lambda_{\ell-}^c - \lambda_{\ell+}^c) \cdot \phi_{\ell,i}^c(L) + \beta_i^c = 0, \quad \forall i \in N, c \in C \\
& -E_c \left[\frac{\partial CP_i^c(q_i^c, g_i^c)}{\partial g_i^c} \right] - \frac{\partial CIG_i(g_i, g_i^0)}{\partial g_i} = 0, \quad \forall i \in N \\
& -\frac{\partial CI_\ell(f_\ell, f_\ell^0)}{\partial f_\ell} + E_c[\lambda_{\ell-}^c + \lambda_{\ell+}^c] = 0, \quad \forall \ell \in L \\
& \sum_{i \in N} r_i^c = 0, \quad \forall c \in C \\
& -f_\ell^c \leq \sum_{i \in N} \phi_{\ell,i}^c(L) \cdot r_i^c \leq f_\ell^c, \quad \forall \ell \in L, c \in C \\
& q_i^c + r_i^c \geq 0, \quad \forall i \in N, c \in C \\
& q_i^c \geq 0, \quad \forall i \in N, c \in C \\
& \lambda_{\ell-}^c \cdot \left(f_\ell^c + \sum_{i \in N} \phi_{\ell,i}^c(L) \cdot r_i^c \right) = 0, \quad \forall \ell \in L, c \in C \\
& \lambda_{\ell+}^c \cdot \left(f_\ell^c - \sum_{i \in N} \phi_{\ell,i}^c(L) \cdot r_i^c \right) = 0, \quad \forall \ell \in L, c \in C \\
& \beta_i^c \cdot (q_i^c + r_i^c) = 0, \quad \forall i \in N, c \in C \\
& \gamma_i^c \cdot q_i^c = 0, \quad \forall i \in N, c \in C \\
& \lambda_{\ell-}^c \geq 0, \quad \forall \ell \in L, c \in C \\
& \lambda_{\ell+}^c \geq 0, \quad \forall \ell \in L, c \in C \\
& \beta_i^c \geq 0, \quad \forall i \in N, c \in C \\
& \gamma_i^c \geq 0, \quad \forall i \in N, c \in C
\end{aligned}$$

where α^c is the Lagrange multiplier to the first constraint in the FVISP optimization problem. $\lambda_{\ell-}^c$ and $\lambda_{\ell+}^c$ are the Lagrange multipliers to the transmission capacity constraints, β_i^c are the Lagrange multipliers to the nonnegativity constraint on local consumption and γ_i^c are the Lagrange multipliers to the nonnegativity constraints on local production

Integrated-resources-planner (IRP) model

In this model, we assume that the IRP jointly plans generation and transmission expansions, although the energy market operation is still decentralized. The IRP model consists of two periods: A and B. The last period (period B) corresponds to the energy market operation and it is identically modeled to the third period of the PSO model. In

the first period (period A), the IRP jointly decides the generation investment levels and the social-welfare-maximizing location and magnitude for the next transmission expansion. Hence, in period A, the IRP solves the following social-welfare-maximizing problem:

$$\text{Max}_{\{g_i\}, \ell, f_\ell} \sum_{i \in N} \left\{ E_c \left[\int_0^{q_i^c + r_i^c} P_i^c(q) dq - CP_i^c(q_i^c, g_i^c) \right] - CIG_i(g_i, g_i^0) \right\} - CI_\ell(f_\ell, f_\ell^0)$$

s.t. Spot Market Equilibrium Conditions.

Reactive system operator (RSO) model

In this model, the system operator (network planner) plans the social-welfare-maximizing location and magnitude for the next transmission expansion while considering the currently installed generation capacities. This model consists of three periods: a, b and c. The last period (period c) corresponds to the energy market operation and it is modeled identically to the third period of the PSO model. Period b is modeled identically to period 2 of the PSO model. In period a, the RSO plans the social-welfare-maximizing location and magnitude of the next transmission expansion based on the currently installed generation capacities and the implied spot market characterized by (the spot market equilibrium conditions That is, the RSO does not take into consideration the potential effect that its decisions could have over the equilibrium of generation capacities. Thus, in period a, the RSO solves the following social-welfare-maximizing problem:

$$\text{Max}_{\ell, f_\ell} \sum_{i \in N} \left\{ E_c \left[\int_0^{q_i^c + r_i^c} P_i^c(q) dq - CP_i^c(q_i^c, g_i^c) \right] - CIG_i(g_i, g_i^0) \right\} - CI_\ell(f_\ell, f_\ell^0)$$

s.t. Spot market Equilibrium Conditions

$$g_i = g_i^0, \quad \forall i \in N$$

In evaluating the outcome of RSO investment policy we are considering the generators' response to that investment and its implication on the spot market equilibrium.

Models comparison

Based on the above formal characterization of the transmission investment decision problems solved by PSO, RSO, FVISP, and IRP, we can prove analytically the following statements that compare the outcomes of these decision paradigms. The formal proofs of these results are contained in the paper by Enzo, Sauma and Shmuel Oren¹⁸ and will be omitted here due to space limitation.

Result 1: The optimal expected social welfare obtained from the fully-vertically-integrated social planner model is never smaller than the optimal expected social welfare obtained from the integrated-resources planner model.

¹⁸Enzo, Sauma and Shmuel Oren "Proactive Planning and Valuation of Transmission Investments in Restructured Electricity Markets." *Journal of Regulatory Economics*, Vol. 30, (2006), pp. 261-290.

Result 2: The optimal expected social welfare obtained from the integrated-resources planner model is never smaller than the optimal expected social welfare obtained from the proactive system operator model.

Result 3: The optimal expected social welfare obtained from the proactive system operator model is never smaller than the optimal expected social welfare obtained from the reactive system operator model.

The above results can be summarized as follows:

The optimal expected social welfares (W) obtained from the FVISP, IRP, PSO, and RSO models are always ordered as follows: $W_{RSO} \leq W_{PSO} \leq W_{IRP} \leq W_{FVISP}$.

This result establishes a hierarchy in terms of the social benefit of a plan. According to this hierarchy, the best outcome can be achieved by a fully vertically integrated social planner (FVISP) who co-optimizes transmission and generation investment and also dispatches all the generation resources in real time economically (i.e. perfect economic dispatch). The second best outcome is achieved under integrated resource planning (IRP) which co-optimizes transmission and generation investment while anticipating that generators (which are privately owned) will be dispatched strategically so as to maximize owners profits. These are not realistic scenarios but they provides useful benchmarks for the realistic cases in which generation investment is decided by generation firms in response to transmission investments and in anticipation of a strategic energy market outcome. The proactive system operator (PSO), which is third in the hierarchy, plans transmission expansion while anticipating both the strategic investment and the strategic dispatch of generation firms who will react both to transmission investments and anticipate the energy market outcome. The lowest in the hierarchy is the reactive system operator (RSO) (which represents prevalent transmission planning practices in restructured electricity markets in the US). The RSO plans transmission in response to generation investment plans, ignoring how such transmission investment may alter the generation investment and subsequent energy market outcome.

While Result 3 above states that an RSO cannot do better (in terms of expected social welfare) than a PSO, the sign of the inefficiency is not evident. That is, without adding more structure to the problem, it is not evident whether the system operator under invests or overinvests in transmission under the RSO model, with respect to the PSO investment levels.

5.3 Case study

We illustrate the theoretical results derived in the previous sections using the 30-bus Cornell network, in which the nodes are located within three zones as displayed in Figure 10. There are six generation firms in the market (each one owning the generation capacity at a single node). Nodes 1, 2, 13, 22, 23, and 27 are the generation nodes. There are 39 transmission lines. The electric characteristics of the transmission lines are listed in Table

1

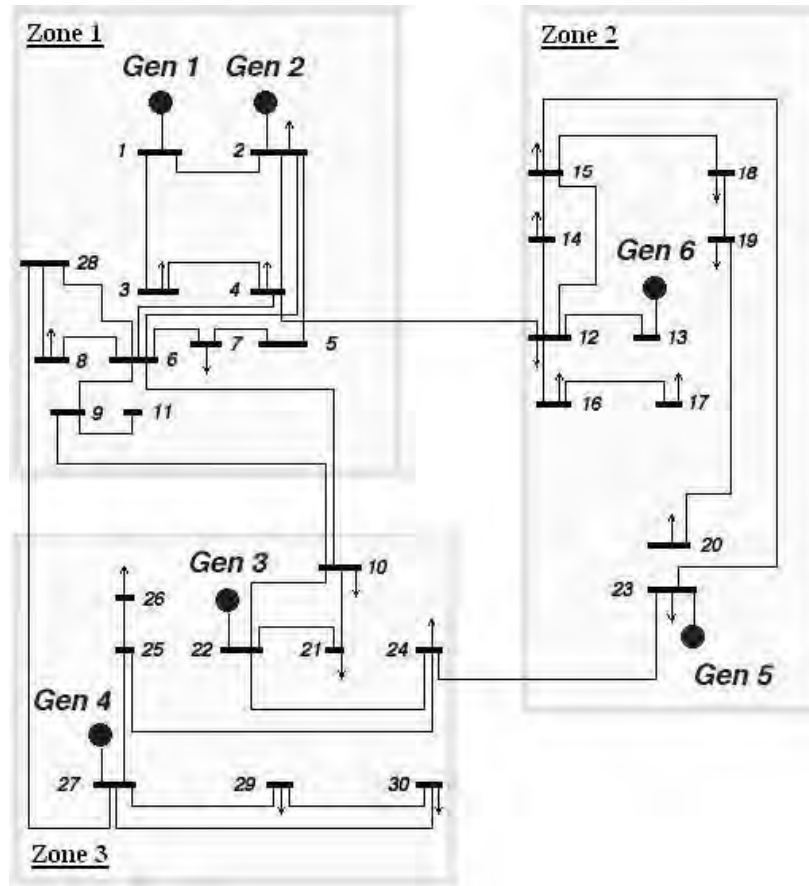

Figure 10: 30-bus Cornell network

Table 1: Electric characteristics of the transmission lines of the 30-bus Cornell network

Line #	From node #	To node #	Resistance (p.u.)	Reactance (p.u.)	f_t^0 (MVA)
1	1	2	0.02	0.06	130
2	1	3	0.05	0.19	130
3	2	4	0.06	0.17	65
4	3	4	0.01	0.04	130
5	2	5	0.05	0.20	130
6	2	6	0.06	0.18	65
7	4	6	0.01	0.04	90
8	5	7	0.05	0.12	70
9	6	7	0.03	0.08	130
10	6	8	0.01	0.04	32
11	6	9	0.00	0.21	65
12	6	10	0.00	0.56	32
13	9	11	0.00	0.21	65
14	9	10	0.00	0.11	65
15	4	12	0.00	0.26	65
16	12	13	0.00	0.14	65
17	12	14	0.12	0.26	32
18	12	15	0.07	0.13	32
19	12	16	0.09	0.20	32
20	14	15	0.22	0.20	16
21	16	17	0.08	0.19	16
22	15	18	0.11	0.22	16
23	18	19	0.06	0.13	16
24	19	20	0.03	0.07	32
25	10	21	0.03	0.07	32
26	10	22	0.07	0.15	32
27	21	22	0.01	0.02	32
28	15	23	0.10	0.20	16
29	22	24	0.12	0.18	16
30	23	24	0.13	0.27	16
31	24	25	0.19	0.33	16
32	25	26	0.25	0.38	16
33	25	27	0.11	0.21	16
34	28	27	0.00	0.40	65
35	27	29	0.22	0.42	16
36	27	30	0.32	0.60	16
37	29	30	0.24	0.45	16
38	8	28	0.06	0.20	32
39	6	28	0.02	0.06	32

The uncertainty associated with the energy market operation is classified into seven independent contingent states (see Table 2). Six of them have small independent probabilities of occurrence (two involve demand uncertainty, two involve network uncertainty and the other two involve generation uncertainty). Table 3 shows the nodal information in the normal state.

Table 2: States of contingencies associated to the energy market operation

State	Probability	Type of uncertainty and description
1	0.82	Normal state: Data set as in table 5.3
2	0.03	Demand uncertainty: All demands increase by 10%
3	0.03	Demand uncertainty: All demands decrease by 10%
4	0.03	Network uncertainty: Line 15-23 goes down
5	0.03	Network uncertainty: Line 23-24 goes down
6	0.03	Generation uncertainty: Generator at node 1 goes down
7	0.03	Generation uncertainty: Generator at node 13 goes down

Table 3: Nodal information used in the 30-bus Cornell network in the normal state of contingency

Data type (units)	Information	Nodes where apply
Inverse demand function (\$/MWh)	$P_i(q) = 50 - q$	1, 2, 5, 6, 9, 11, 13, 16, 18, 20, 21, 22, 25, 26, 27, 28, and 29.
Inverse demand function (\$/MWh)	$P_i(q) = 55 - q$	4, 8, 10, 12, 14, 15, 17, 19, 24, and 30.
Inverse demand function (\$/MWh)	$P_i(q) = 60 - q$	3, 7, and 23.
Generation cost function (\$/MWh)	$CP_i(q_i, g_i) = (0.25 \cdot q_i^2 + 20 \cdot q_i) \cdot (g_i^0 / g_i)$	1, 2, 13, 22, 23, and 27 (all generation nodes).

As shown in Table 3, we assume the same production cost function, $CP_i^c(\cdot)$, for all generators. Note that $CP_i^c(\cdot)$ is increasing in q_i^c , but it is decreasing in g_i^c . Moreover, recall that we have assumed generators have unbounded capacity (i.e., they never reach the upper generation capacity limit). Thus, the only important effect of investing in generation capacity is lowering the production cost. We also assume that all generation firms have the same investment cost function, given by $CIG_i(g_i, g_i^0) = 8 \cdot (g_i - g_i^0)$, in dollars. The before-period-2 expected generation capacity at node i , g_i^0 , is 60 MW (the same for all generation nodes). In our model, the choice of the parameter g_i^0 is not important because the focus of this thesis is not generation adequacy. Instead, what really matters in our model is the ratio (g_i^0/g_i) since we focus on the cost of generating power and the effect that both generation and transmission investments have on that cost.

The KKT conditions for the period-3 problem of the PSO model constitute a Linear Complementarity Problem (LCP). We solve it, for each contingent state by minimizing the complementarity conditions subject to the linear equality constraints and the non-

negativity constraints.¹⁹ The period-2 problem of the PSO model is an Equilibrium Problem with Equilibrium Constraints (EPEC), in which each firm faces a Mathematical Program subject to Equilibrium Constraints (MPEC). We do not attempt to solve this optimization problem. Rather than that, we attempt to find an equilibrium point, if at least one exists, by iterative deletion of dominated strategies. That is, we sequentially look for an equilibrium point of each firm's profit-maximization problem using as data the generation capacities resulting from previously found equilibria. Thus, starting from a feasible solution, we look for g_1 in equilibrium by using $g_{(-1)}$ as data in the first firm's optimization problem (where $g_{(-1)}$ means all firms' generation capacities except for firm 1's), then look for g_2 in equilibrium by using $g_{(-2)}$ as data, and so on. We attempt to find an equilibrium of each firm's profit-maximization problem using sequential quadratic programming algorithms implemented in MATLAB[®].

We test our model from a set of different starting points and using different generation-firms' optimization order. All these trials gave us the same results. For the PSO model, the levels of generation capacity in equilibrium under absence of transmission investments are $(g_1^*, g_2^*, g_3^*, g_4^*, g_5^*, g_6^*) = (100.92, 103.72, 101.15, 95.94, 77.07, 87.69)$, in MW. Table 5.4 lists the corresponding generation quantities (q_i), adjustment quantities (r_i) and nodal prices (P_i) in the normal state of contingency. Figure 5.3 illustrates these results in the Cornell network. In Figure 3, thick lines represent the transmission lines reaching their thermal capacities (in the indicated direction) and circles correspond to those nodes with the highest prices (above \$48/MWh).

To evaluate the period-1 decision under the PSO model, we iteratively look for equilibria of period-2 problems in which a single line has been expanded and, then, choose the expansion producing the highest expected social welfare. For simplicity, we do not consider transmission investment costs (it can be thought that the per-unit transmission investment cost is the same for each line upgrade so that we can get rid of these costs in the expansion decision). In this sense, our results establish an upper limit in the amount of the line investment cost. The four congested lines in the normal state, under absence of transmission investment, are some obvious candidates for the single line expansion. We tested the PSO decision by comparing the results of independently adding 100 MVA of capacity to each one of these four lines and to four new lines. The results are summarized in Table 5. In Table 5, "Avg. L" corresponds to the average expected Lerner index²⁰ among all generation firms, "P.S." is the expected producer surplus of the system, "C.S." is the expected consumer surplus of the system, "C.R." represents the expected congestion rents over the entire system, "W" is the expected social welfare of the system, and "g*" corresponds to the vector of all Nash-equilibrium expected generation capacities.

¹⁹ Recall that any LCP can be written as the problem of finding a vector $x \in \mathfrak{R}^n$ such that $x = q + M \cdot y$, $x^T \cdot y = 0$, $x \geq 0$, and $y \geq 0$, where $M \in \mathfrak{R}^{n \times n}$, $q \in \mathfrak{R}^n$, and $y \in \mathfrak{R}^n$. Thus, we can solve it by minimizing $x^T \cdot y$ subject to $x = q + M \cdot y$, $x \geq 0$, and $y \geq 0$. If the previous problem has an optimal solution where the objective function is zero, then that solution also solves the corresponding LCP.

²⁰ The Lerner Index is defined as the fractional price markup, i.e. (Price – Marginal cost) / Price.

Table 4: Generation quantities, adjustment quantities, and nodal prices in normal state, in the PSO model, under absence of transmission investments

Node	q_i (MWh)	r_i (MWh)	P_i (\$/MWh)
1	27.397	-24.827	47.43
2	27.808	-25.230	47.42
3	0	12.544	47.46
4	0	7.539	47.46
5	0	2.600	47.40
6	0	2.624	47.38
7	0	12.614	47.39
8	0	7.630	47.37
9	0	2.838	47.16
10	0	7.950	47.05
11	0	2.838	47.16
12	0	6.932	48.07
13	24.706	-21.547	46.84
14	0	6.799	48.20
15	0	6.612	48.39
16	0	1.932	48.07
17	0	6.932	48.07
18	0	1.022	48.98
19	0	6.022	48.98
20	0	1.022	48.98
21	0	3.033	46.97
22	27.055	-23.997	46.94
23	21.724	-7.474	45.75
24	0	8.474	46.53
25	0	3.152	46.85
26	0	3.152	46.85
27	26.310	-23.354	47.04
28	0	2.663	47.34
29	0	2.500	47.50
30	0	7.007	48.00

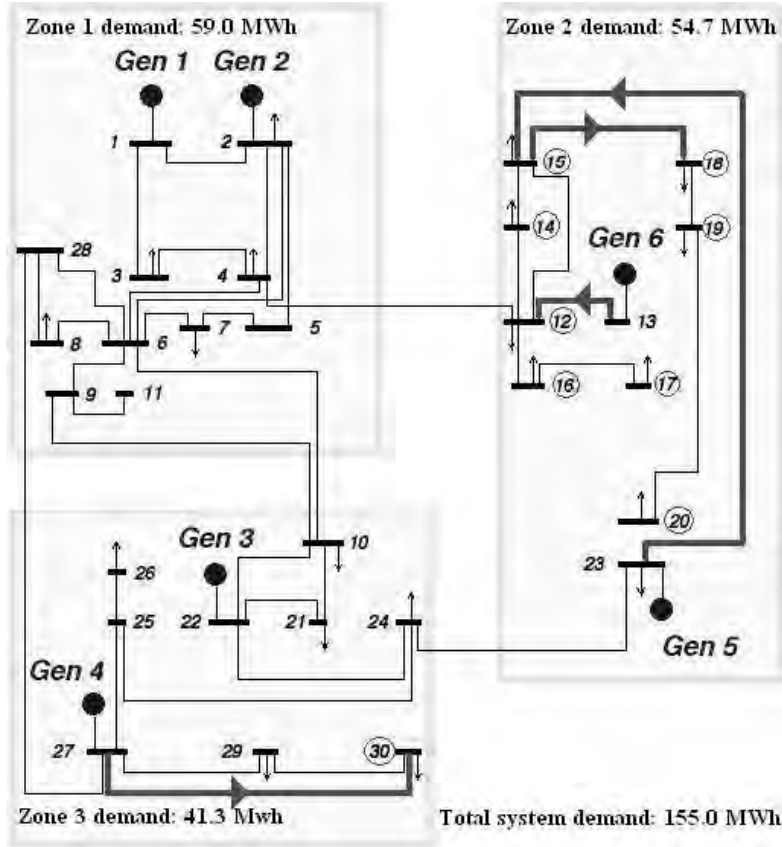

Figure 11: Results of the PSO model in the normal state, under absence of transmission investment, for the 30-bus Cornell network

Table 5: Assessment of single transmission expansions under the PSO model

Expansion Type	Avg.L	P.S. (\$/h)	C.S. (\$/h)	C.R. (\$/h)	W (\$/h)	g^* (MW)
No expansion	0.552	2975.2	574.7	68.4	3618.3	[100.92; 103.72; 101.15; 95.94; 77.07; 87.69]
100 MVA on line 12-13	0.561	3015.7	591.3	39.9	3646.9	[100.62; 103.40; 100.93; 98.50; 78.56; 97.99]
100 MVA on line 15-18	0.556	2957.0	576.5	82.6	3616.1	[101.35; 104.09; 101.01; 94.38; 79.28; 92.71]]
100 MVA on line 15-23	0.571	3049.9	602.2	26.4	3678.5	[100.01; 102.80; 102.90; 102.37; 101.45; 85.06]
100 MVA on line 27-30	0.555	2986.1	581.1	58.2	3625.4	[101.10; 103.89; 101.40; 101.46; 77.68; 86.30]
100 MVA on new line 2-18	0.563	3049.0	579.9	36.6	3665.5	[100.72; 103.45; 103.09; 103.04; 76.97; 95.29]
100 MVA on new line 18-27	0.569	3052.8	588.5	37.5	3678.8	[101.01; 103.80; 102.41; 103.57; 84.36; 96.12]
100 MVA on new line 20-22	0.561	3089.7	583.5	12.3	3685.5	[101.13; 103.93; 103.93; 102.04; 84.31; 82.82]
100 MVA on new line 13-20	0.566	3041.8	592.8	31.4	3666.0	[101.12; 103.89; 101.15; 100.96; 80.15; 99.67]

From Table 5, it is evident that the best single transmission line expansion (in terms of expected social welfare) that a proactive system operator can choose in this case is to build a new line connecting nodes 20 and 22. Moreover, it is interesting to observe that some expansion projects (as adding 100 MVA on line 15-18) can decrease social welfare.

Now, we are interested in comparing the PSO decision with the decision that would take a reactive system operator under the same system conditions. We tested the RSO decision by comparing the results of independently adding 100 MVA of capacity to each one of the same (existing and new) eight lines as before. The results are summarized in table 5.6, where we use the notation \bar{x} to represent the value of x as seen by the RSO.

Table 6: Assessment of single transmission expansions under the RSO model

Expansion Type	$\overline{\text{Avg.L}}$	$\overline{\text{P.S.}}$ (\$/h)	$\overline{\text{C.S.}}$ (\$/h)	$\overline{\text{C.R.}}$ (\$/h)	$\overline{\text{W}}$ (\$/h)
No expansion	0.395	2732.4	387.9	9.1	3129.4
100 MVA on line 12-13	0.395	2732.4	388.3	8.9	3129.6
100 MVA on line 15-18	0.395	2732.1	388.3	8.9	3129.3
100 MVA on line 15-23	0.395	2732.5	388.2	8.8	3129.5
100 MVA on line 27-30	0.395	2732.4	387.9	9.1	3129.4
100 MVA on new line 2-18	0.396	2750.4	386.8	0.5	3137.7
100 MVA on new line 18-27	0.396	2751.0	386.8	0.2	3138.0
100 MVA on new line 20-22	0.396	2750.7	386.8	0.3	3137.8
100 MVA on new line 13-20	0.395	2742.6	387.2	4.3	3134.1

From Table 6, it is clear that the social-welfare-maximizing transmission expansion for the RSO is, in this case, to build a new transmission line connecting nodes 18 and 27. Thus, the true optimal levels of the RSO model solution are: Avg. L = 0.569, P.S. = \$3,052.8 /h, C.S. = \$ 588.5 /h, C.R. = \$ 37.5 /h, W = \$ 3,678.8 /h, and $g^* = (101.01, 103.80, 102.41, 103.57, 84.36, 96.12)$, in MW. By comparing table 5.5 and table 5.6, it is evident that the optimal decision of the PSO differs from the optimal decision of its reactive counterpart. Specifically, the PSO considers not only the welfare gained directly by adding transmission capacity (on which the RSO bases its decision), but also the way in which its investment induces a more socially efficient Nash equilibrium of expected generation capacities.

It is also interesting to compare the results obtained with the PSO model and those obtained with a hypothetical IRP. We tested the IRP decision by comparing the results of independently adding 100 MVA of capacity to each one of the same eight lines as before. The results are summarized in Table 7.

Table 7: Assessment of single transmission expansions under the IRP model

Expansion Type	Avg.L	P.S. (\$/h)	C.S. (\$/h)	C.R. (\$/h)	W (\$/h)	g^* (MW)
No expansion	0.549	2979.5	571.1	68.5	3619.0	[100.56; 100.06; 99.67; 96.24; 77.12; 87.61]
100 MVA on line 12-13	0.564	3009.7	596.4	44.3	3650.4	[101.17; 103.90; 97.61; 97.68; 85.15; 97.87]
100 MVA on line 15-18	0.554	2969.9	578.6	70.9	3619.4	[103.00; 107.98; 95.63; 93.94; 83.92; 85.28]
100 MVA on line 15-23	0.568	3053.1	597.0	30.1	3680.2	[98.12; 100.87; 101.22; 101.07; 99.93; 87.20]
100 MVA on line 27-30	0.555	2989.4	582.2	55.9	3627.5	[102.02; 102.66; 100.64; 100.67; 80.48; 84.04]
100 MVA on new line 2-18	0.547	3096.7	565.0	8.7	3670.4	[96.09; 102.56; 95.92; 102.86; 76.83; 81.07]
100 MVA on new line 18-27	0.567	3055.8	585.6	38.2	3679.6	[100.10; 102.69; 101.13; 102.08; 84.72; 96.08]
100 MVA on new line 20-22	0.556	3094.9	576.5	15.7	3687.1	[96.51; 102.19; 101.22; 99.57; 84.78; 84.16]
100 MVA on new line 13-20	0.561	3045.1	588.0	34.9	3668.0	[102.04; 98.35; 96.17; 96.84; 86.21; 96.89]

From Table 7, it is clear that the social-welfare-maximizing transmission expansion for the IRP is, in this case, to build a new line connecting nodes 20 and 22 (the same as in the PSO model). By comparing Table 5 and Table 7, we can observe that, although the IRP makes the same decision as the PSO, this IRP is able to increase the expected social welfare by choosing generation capacities that are more socially efficient than those chosen by the generation firms in the PSO model. However, the gain in social welfare of moving from the PSO model to the IRP model is very small (less than \$ 2 /h).

Finally, it is interesting to compare the results obtained with the PSO model and those obtained with an hypothetical FVISP. We tested the FVISP decision by comparing the results of independently adding 100 MVA of capacity to each one of the same eight lines as before. The results are summarized in Table 8.

From Table 8, it is clear that the social-welfare-maximizing transmission expansion for the FVISP is, in this case, to build a new line connecting nodes 18 and 27. By comparing tables 5, 6, 7, and 8, we can observe that this FVISP is able to significantly increase the expected social welfare with respect to the RSO, the PSO and the IRP. This is because the FVISP not only jointly plans generation and transmission expansions, but also chooses generation quantities and redispatch amounts in order to maximize the expected social welfare of the whole system. In this sense, it is also interesting to note that the producer surplus under every expansion project studied here is negative, which is a result of the fact that the FVISP controls all decision variables in the maximization of the entire-system's expected social welfare.

Table 8: Assessment of single transmission expansions under the FVISP model

Expansion Type	Avg.L	P.S. (\$/h)	C.S. (\$/h)	C.R. (\$/h)	W (\$/h)	g^* (MW)
No expansion	0.008	-550.0	3729.6	3506.6	6686.2	[163.15; 109.27; 165.42; 121.92; 111.68; 103.37]
100 MVA on line 12-13	0.008	-590.7	3831.3	3728.4	6969.0	[163.87; 108.29; 165.43; 121.92; 111.72; 123.70]
100 MVA on line 15-18	0.008	-550.0	3728.9	3507.4	6686.3	[163.15; 109.27; 165.43; 121.92; 111.68; 103.37]
100 MVA on line 15-23	0.008	-605.3	3795.2	3938.6	7128.5	[155.55; 119.89; 165.42; 121.92; 133.79; 103.37]
100 MVA on line 27-30	0.008	-559.8	3800.8	3505.9	6746.9	[163.15; 109.27; 165.43; 127.23; 111.67; 103.37]
100 MVA on new line 2-18	0.008	-636.1	4107.6	4003.2	7474.7	[156.24; 184.86; 165.43; 121.92; 102.32; 103.38]
100 MVA on new line 18-27	0.008	-639.5	4165.6	3993.0	7519.1	[160.33; 112.88; 165.42; 189.20; 108.46; 103.38]
100 MVA on new line 20-22	0.008	-596.5	4115.5	3989.7	7508.7	[159.75; 113.82; 232.91; 121.92; 102.49; 103.38]
100 MVA on new line 13-20	0.008	-658.8	4244.5	3849.4	7435.1	[164.21; 107.69; 165.43; 121.92; 111.47; 172.87]

5.4 Documentation

The work presented in this section was documented in several presentations and publications:

Sauma Enzo E. and Shmuel S. Oren., “Assessing the Economic Value of Transmission Investments in Restructured Electricity Markets”, Proceedings of the ICORAID-2005-ORS Conference, Bangalore, India, December 27-29, 2005.

Sauma Enzo E. and Shmuel S. Oren., “Proactive Transmission Investment in Competitive Power Systems”, Proceeding of the IEEE PES Annual Meeting, Montreal, Canada, July 18-22, 2006.

Sauma Enzo E. and Shmuel S. Oren., “Proactive Planning and Valuation of Transmission Investments in Restructured Electricity Markets”. *Journal of Regulatory Economics*, Vol. 30, (2006), pp. 261-290

6. Conclusions and Recommendations

While traditionally transmission expansion has been driven primarily by reliability considerations and coordinated with generation expansion through centralized integrated resource planning, the transition to competitive electricity market has changed the landscape so that economic criteria and economic impact play an increasing role in transmission expansion decisions and the funding mechanisms for such expansion. There is growing evidence, however, that the U.S. transmission system is under stress has given rise to a wide range of challenges and exciting new opportunities for both economists and engineers to contribute to the effective design of the future electricity industry. It is broadly recognized now that creating a competitive market for energy is not enough to produce sufficient incentives for transmission expansion so that merchant transmission will meet the need for investment in the transmission infrastructure. Furthermore, while market forces can partially respond to such need it is unlikely that such a generation centric paradigm will result in a co-optimized resource plan of generation and transmission. To address this issue we have introduced a framework for transmission planning that takes into consideration planning objectives and market interactions

In our analysis we have demonstrated how transmission investment that would be beneficial from a social welfare perspective could be blocked because of diverse incentives of different stake holders which may be adversely impacted. We have also shown how different planning objectives that reflect the interests of different stakeholders might lead to conflicting investment choices.

We demonstrated with a simple illustrative example how in the presence of market power, strategic responses to transmission expansion through generation investment decisions and production decisions in the spot market may in fact circumvent the primary objective of the investment. This observation negates popular beliefs that market power can be assumed away in economic assessment of transmission investments and that mitigation of market power is always an added benefit of such expansion.

We explored how incentives of stakeholders with regard to transmission expansions may be better aligned with social objectives. One approach to creating such alignment is through the formation of coalitions and cost allocation schemes based on cooperative game theory. Another approach is to align generators incentives with social goals is through the allocation of transmission rights (FTR).

We introduced a new economic assessment scheme that is based on viewing the transmission planner as a leader whose objective is to maximize social welfare by facilitating trade and affecting strategic responses and competitive interaction so as to benefit society. We have demonstrated theoretically and through a numerical example how accounting for generation strategic responses to transmission investment may affect the investment decision. Such a proactive approach is superior to reactive transmission planning that responds to current generation assets while ignoring strategic responses of the generation firms to new transmission assets. Furthermore we have demonstrated that

a proactive planning approach can recuperate some of the lost coordination benefits due to abandonment of the integrated resource planning paradigm that is no longer practical in a market based system.

The main recommendations based on this investigation are;

- Transmission planning should be proactive and viewed as a mechanism to guide and enable the energy market rather than being a reactive response driven by generation investment decisions.
- Diverse economic impacts of transmission planning is a reality that must be contended with through formation of coalitions and through the use of market instruments such as FTRs and innovative cost allocation schemes.
- Market power can circumvent the objectives of transmission expansion. Hence strategic interactions among market participants and profit motives must be accounted for and anticipated in transmission planning models.
- Economic valuation of transmission projects and their impacts must fully account for strategic interactions and strategic responses to the transmission expansion by generation firms.

7. References

Contreras, J.; G. Gross, I. Ruiz-Gomez, and J.M. Arroyo. "A Scheme For Incentivizing Investments and Cost Sharing in Transmission Enhancements." Proceedings of PSCC 2008, Glasgow, United Kingdom. July 14-18, 2008.

Enzo, Sauma; and Shmuel Oren. "Aligning Generators' Interests with Social Efficiency Criteria for Transmission Upgrades in an LMP Based Market", *Proceeding of the IEEE PES Annual Meeting*, Tampa, Florida. June 24-28, 2007.

Enzo, Sauma; and Shmuel Oren. "Alternative Economic Criteria and Proactive Planning for Transmission Investment in Deregulated Power Systems." Working paper, September 2005. (To appear as an IEEE book chapter).

Enzo, Sauma; and Shmuel Oren. "Assessing the Economic Value of Transmission Investments in Restructured Electricity Markets." Proceedings of the ICORAID-2005-ORS Conference, Bangalore, India. December 27-29, 2005.

Enzo, Sauma; and Shmuel Oren. "Do Generation Firms in Restructured Electricity Markets Have Incentives to Support Social-Welfare-Improving Transmission Investments?" *Energy Economics*. In Press, available online February 4, 2009.

Enzo, Sauma; and Shmuel Oren. "Economic Criteria for Planning Transmission Investment in Restructured Electricity Markets." *IEEE Transactions on Power Systems, Special Issue on Transmission Investment, Pricing and Construction*, Vol. 22, No. 4, (2007) pp. 1394-1405.

Enzo, Sauma; and Shmuel Oren. "Proactive Planning and Valuation of Transmission Investments in Restructured Electricity Markets." *Journal of Regulatory Economics*, Vol. 30, (2006), pp. 261-290.

Ezno, Sauma; and Oren, Shmuel. "Proactive Transmission Investment in Competitive Power Systems", *Proceeding of the IEEE PES Annual Meeting*, Montreal, Canada. July 18-22, 2006.

Gross, George. "Transmission Expansion in Competitive Electricity Markets," invited seminar at the University of Pavia, Italy. May 23, 2008.

Gross, George. "Transmission Investment in the Competitive Environment," invited seminar at the University of Texas at Arlington, Texas. January 26, 2007.